

NVIS02

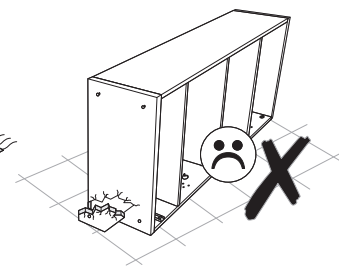

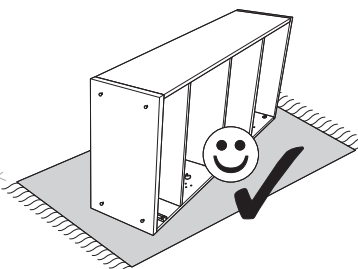
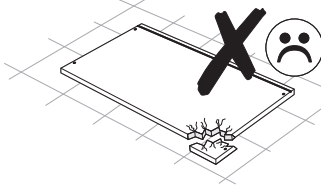
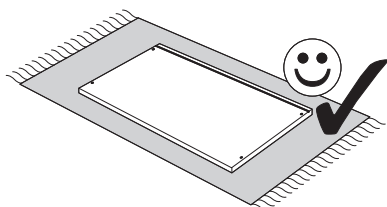
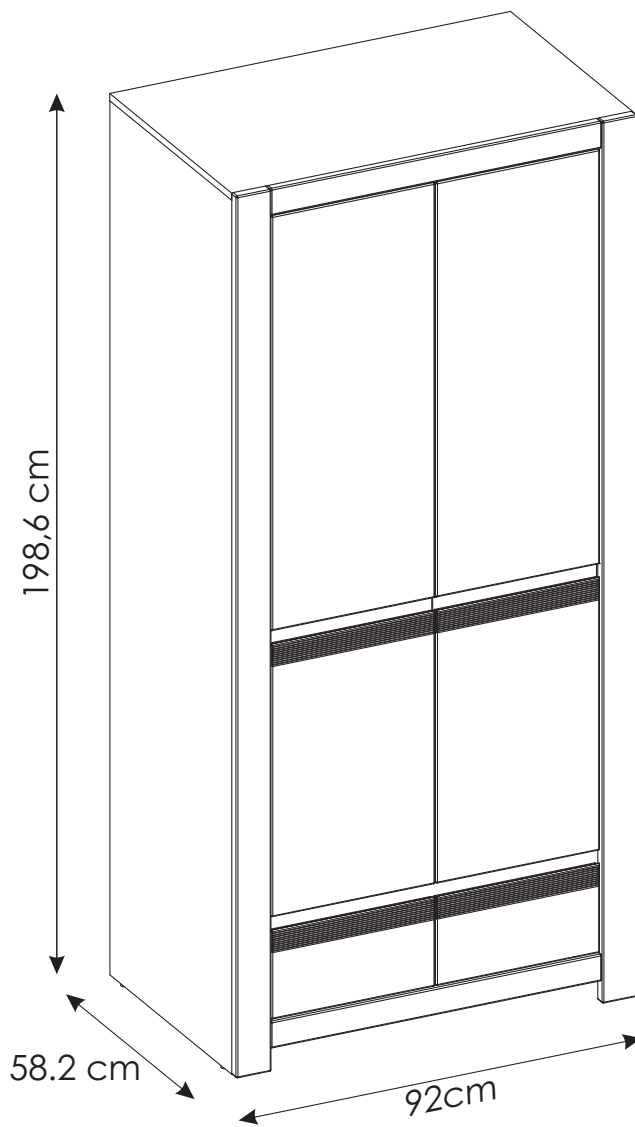
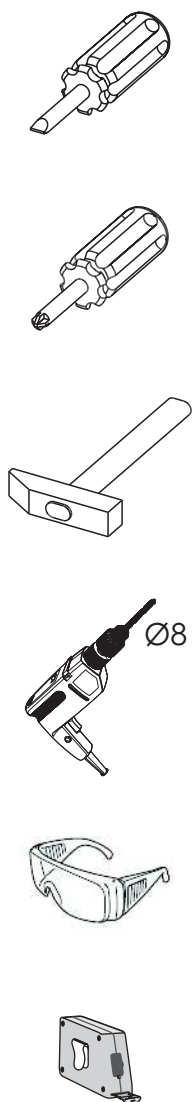
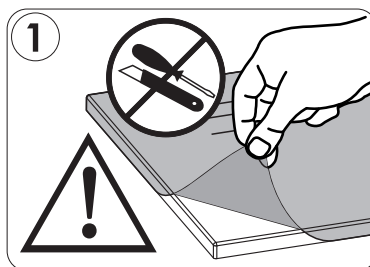
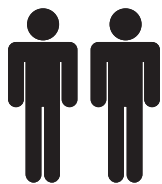
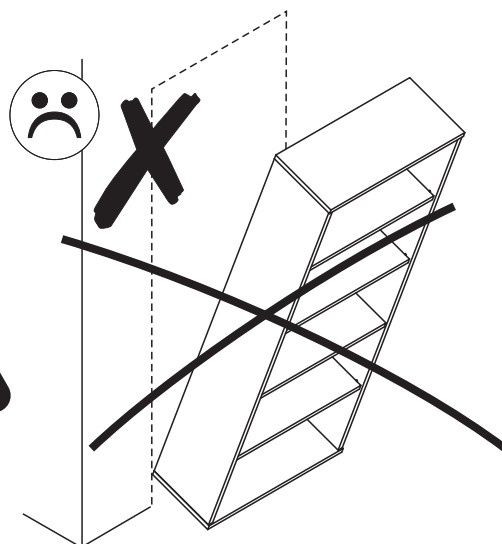
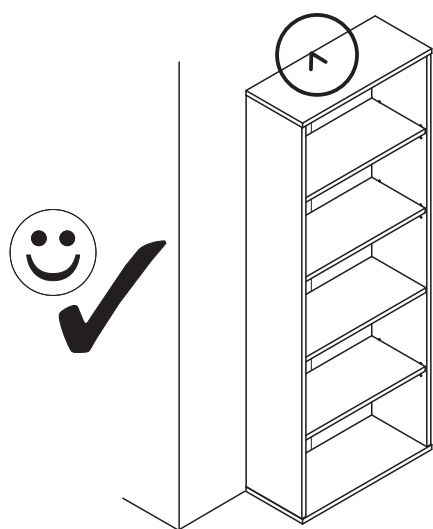

PL.
UWAGA! Mebel należy trwale zamocować do ściany, aby uniknąć ryzyka związanego z przewróceniem się mebla. W paczce znajdują się elementy mocujące odpowiednie wyłącznie do ścian betonowych lub z pełnej cegły. Jeśli Twoja ściana wykonana jest z innego materiału lub nie masz pewności co do budowy tej ściany, skonsultuj się w kwestii montażu ze specjalistą.

D.
ACHTUNG! Um alle mit dem Umkippen des Möbels verbundenen Risiken auszuschließen, muss das Möbel fest an der Wand verankert werden. Die im Paket enthaltenen Beschläge für die Wandbefestigung sind ausschließlich für Wände aus Beton oder Vollziegeln geeignet. Sollten die heimischen Wände aus anderem Baumaterial bestehen oder sollte es Zweifel in Hinsicht auf dieses Baumaterial geben, bitte eine Fachkraft zu Rate ziehen.

FR.
ATTENTION! Ce meuble doit être fixé en permanence au mur pour éviter les risques de chute. L'ensemble comprend des moyens de fixation adaptés uniquement aux murs de béton ou de brique. Si votre mur est fait d'un matériau différent ou si vous êtes incertain quant à la construction du mur, consultez un spécialiste.

I.
ATTENZIONE! Il mobile deve essere permanentemente fissato alla parete per evitare i rischi derivanti da un ribaltamento del mobile. La confezione contiene solo elementi di fissaggio adatti per pareti in calcestruzzo o in laterizio pieno. Se la vostra parete è realizzata in materiale diverso o avete dubbi sulla costruzione della parete, consultare uno specialista per un montaggio corretto.

HR.
NAPOMENA! Namještaj mora biti trajno pričvršćen za zid, kako bi se izbjegao rizik od njegova prevrtanja. U paketu se nalaze elementi za pričvršćivanje prikladni isključivo za betonske zidove ili punu ciglu. Ako je Vaš zid izrađen od drugog materijala ili niste sigurni od čega je napravljen Vaš zid, konzultirajte se sa stručnjakom u vezi sa montažom.

EN.
WARNING! To prevent this furniture from tripping over, fix it to the wall permanently. The package includes fastening elements only suitable for concrete or full-brick walls. If your wall is made of a different material or you are unsure as to the construction of the wall, please consult a specialist regarding installation.

SK.
POZOR! Nábytok musí byť trvalo pripavený k stene tak, aby sa zamedzilo riziku prevrátenia. V balíku sa nachádzajú upevňovacie komponenty výlučne pre betónové steny alebo steny z plnej tehly. Ak je Vaša stena z iného materiálu alebo ak si nie ste istí, z čoho je stena vyhotovená, vyžiadajte si odbornú pomoc.

CZ.
POZOR! Nábytek je nutné pevně připevnit ke zdi, abychom se vyhnuli riziku spojenému s jeho převrnutím. V balíčku se nacházejí připevňující prvky vhodné výhradně do betonových zdí nebo zdí z plných cihel. Pokud jsou Vaše zdi zhotoveny z jiného materiálu nebo si nejste jejich konstrukcí jisti, konzultujte otázku montáže se specialistou.

RO.
Atenție! Pentru a exclude posibilitatea ca mobilierul sa se raspoarte, va rugam sa il fixati in perete. Pachetul include elemente de fixare pentru peretii de caramida sau beton. Daca peretele duneavoastra este realizat din alt tip de material sau nu sunteti sigur de materialul folosit, va rugam sa consultati un specialist referitor la elementele de fixare pentru perete.

E.
¡ATENCIÓN! El mueble debe ser fijado permanentemente a la pared para evitar el riesgo relacionado con el vuelco del mueble. En el paquete hay elementos de fijación adecuados solo para paredes de hormigón o de ladrillo entero. Si su pared está hecha de otro material o no está seguro sobre la construcción de esta pared, consulte el montaje con un especialista.

CN.
注意！本家具需要固定在墙上以免倒塌。本包所含有的固定部件仅适用于混凝土墙及整砖墙。欲使用在其他墙体或不确定墙体时，请向专家询问安装方式。

RU.
ПРИМЕЧАНИЕ! Эту мебель необходимо всегда прикреплять к стене, чтобы избежать рисков, связанных с переворотом мебели. В пакете находятся крепительные элементы, которые подходят исключительно к бетонным стенам или из целого кирпича. Если стена изготовлена из другого материала или Вы не уверены относительно строения стены, проконсультируйтесь относительно монтажа со специалистом.





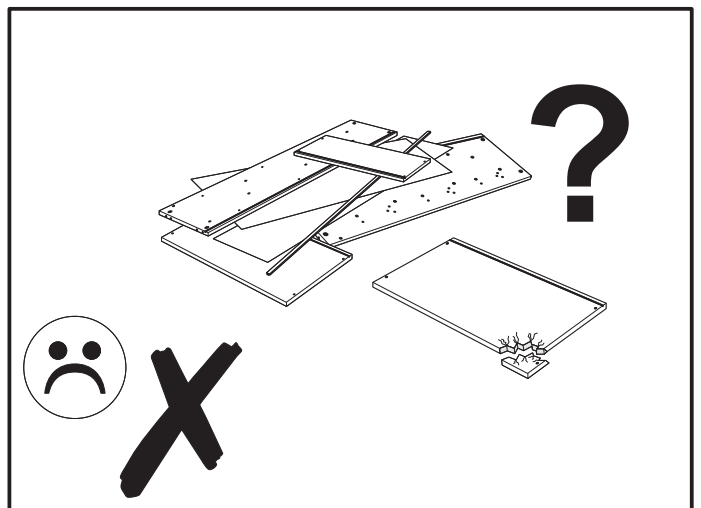
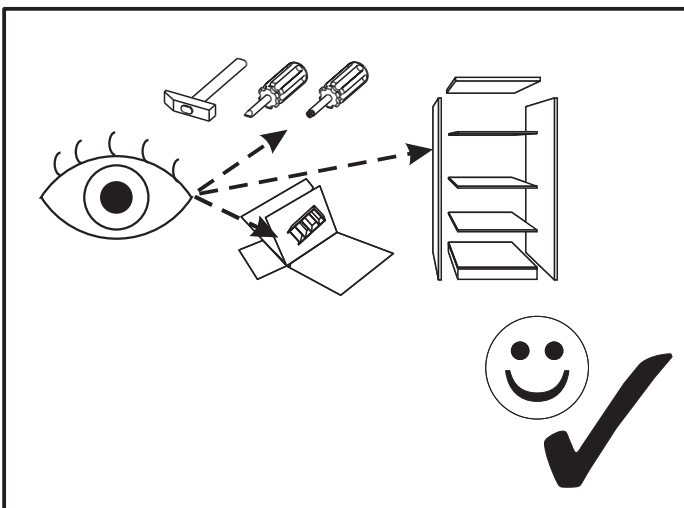
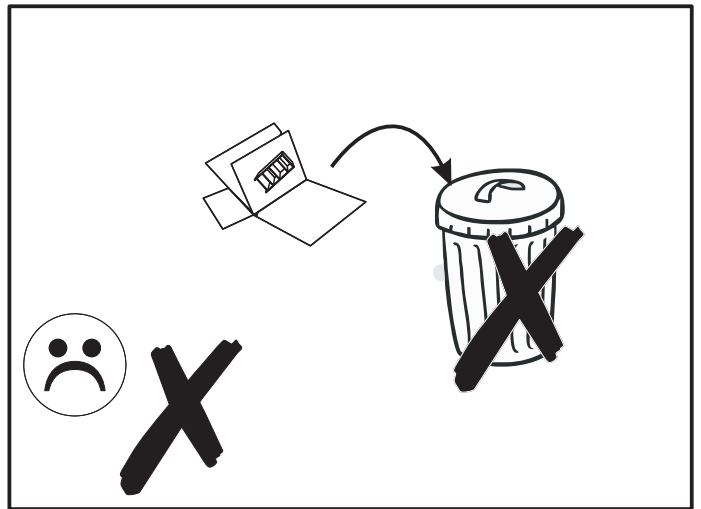
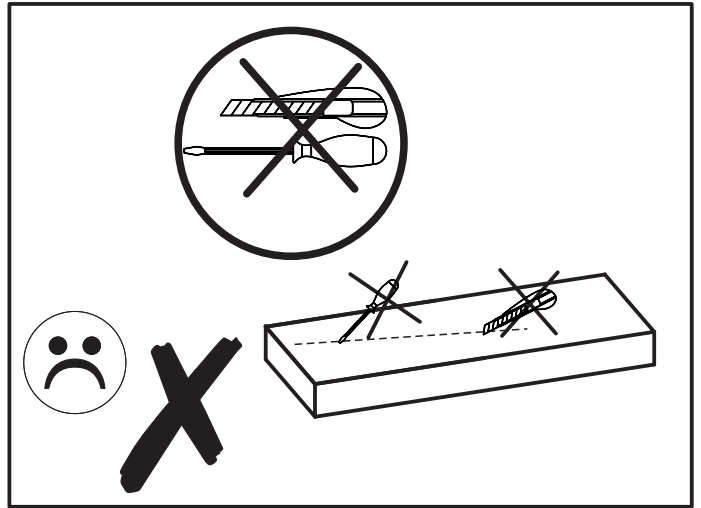
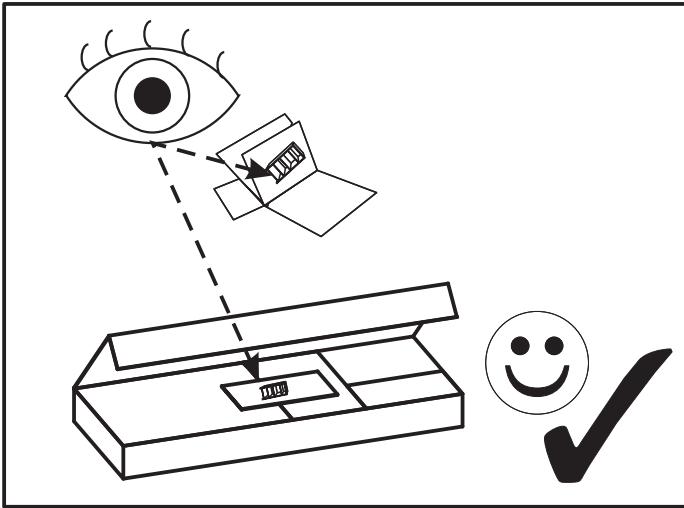





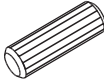
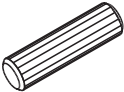
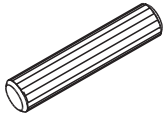
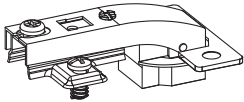

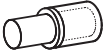

SLO.
POZOR! Pohištvo trajno pritrđite na steno, da preprečite tveganje, da se prevrne. V paketu so pritrđilni elementi, ki so ustrezni izključno za betonske stene in za stene iz polne opeke. Če je vaša stena izdelana iz drugih materialov ali niste gotovi glede konstrukcije stene, se o montaži posvetujte s strokovnjakom.

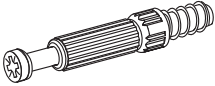
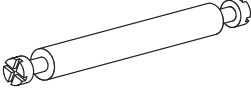
HU.
FIGYELEM! Rögzítse a bútorokat a falhoz, hogy elkerülje a bútor felborulásának kockázatát. A készletben kizárólag beton- vagy téglafalhoz használható kötőelemek találhatóak. Ha a fal más anyagból készült, vagy ha nem tudja, milyen falak találhatóak otthonában, forduljon szakemberhez.

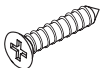
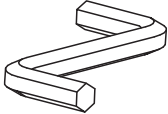

NVIS02

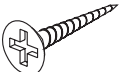
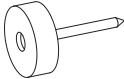
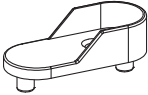
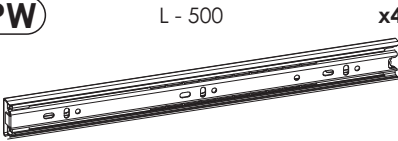
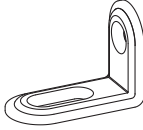
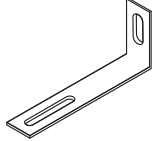
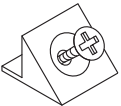
MM

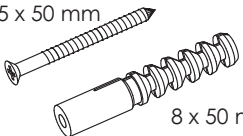
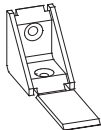
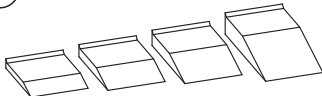
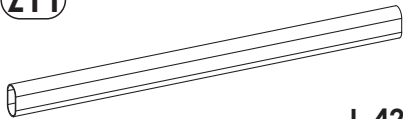
A0 8 x 20 mm x8 	A1 8 x 35 mm x54 	A2 8 x 60 mm x3 
BR1 + BR2 x8 	C1 4 x 13 mm x16 	C2 5 x 13 mm x8 
D2 x16 	E0 x24 	E1 15 x 12 mm x46 
E14 x24 	F1 6 x 34 mm x42 	F2 7 x 76 mm x2 
G1 7 x 50 mm x10 	I2 4 x 16 mm x2 	I18 3,5 x 27 mm x2 
J6 4 x 25 mm x24 	M x1 	N1 3 x 16 mm x30 
N2 3,5 x 16 mm x22 	O2 x6 	P44 x2 
PW L - 500 x4 	Q2 x2 	Q9 x2 
R4 x14 	R8 x8 	S13 5 x 50 mm x2 8 x 50 mm 
W x2 	Z x1 	Z11 x1  L-426

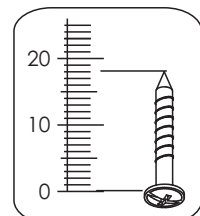
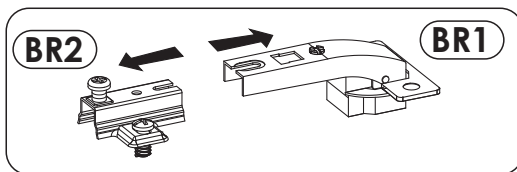
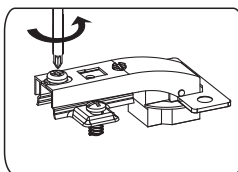
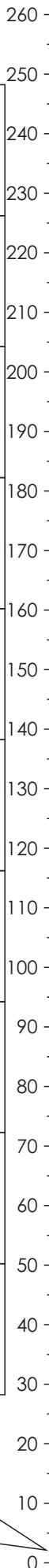

NVIS02

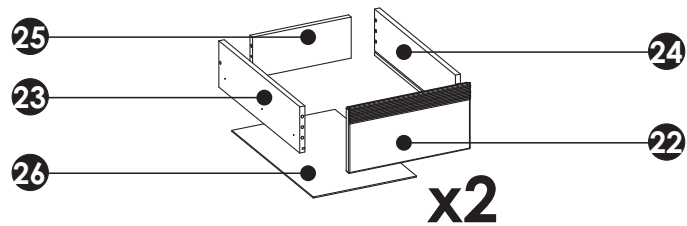
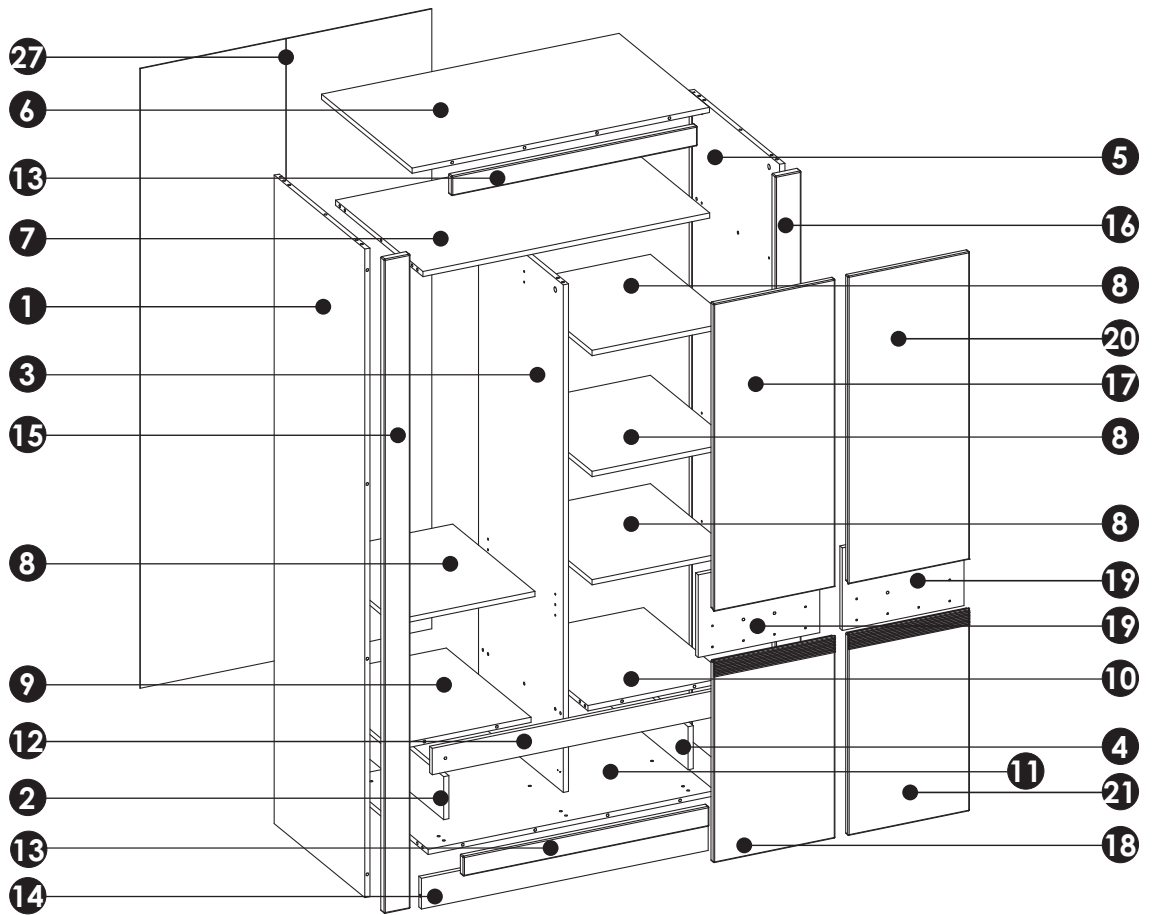
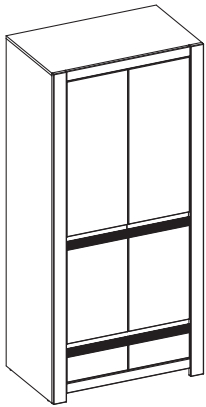

1	1964	560	16 x1	4/4
2	130	540	16 x1	2/4
3	1537	524	16 x1	3/4
4	130	540	16 x1	2/4
5	1964	560	16 x1	4/4
6	920	560	16 x1	2/4
7	887	540	16 x1	1/4
8	435	509	16 x4	1/4
9	435	524	16 x1	1/4

10	435	524	16 x1	1/4
11	887	540	16 x1	1/4
12	887	80	16 x1	2/4
13	760	60	19 x2	4/4
14	887	93	16 x1	2/4
15	1981	80	22 x1	4/4
16	1981	80	22 x1	4/4
17	932	376	16 x1	3/4
18	613	376	16 x1	3/4

19	376	250	16 x2	2/4
20	932	376	16 x1	3/4
21	613	376	16 x1	3/4
22	376	200	16 x2	2/4
23	500	140	16 x2	3/4
24	500	140	16 x2	3/4
25	305	124	16 x2	2/4
26	319	505	3 x2	1/4
27	1877	900	3 x1	4/4

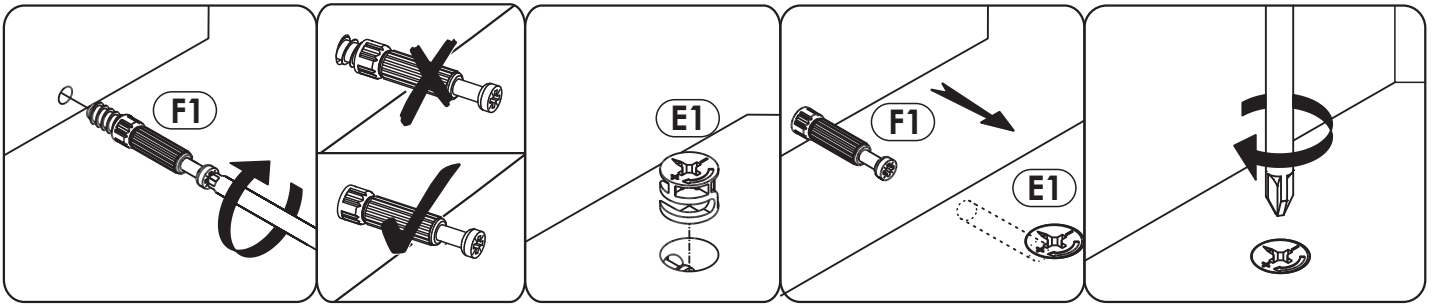

1 ▶

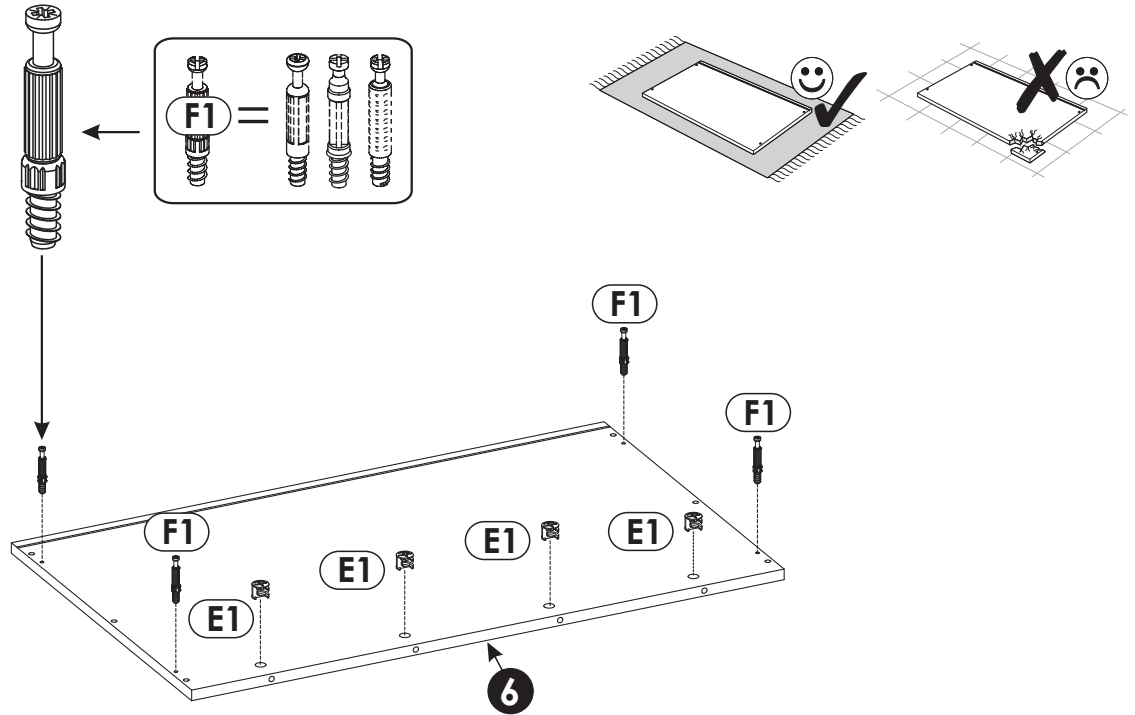

2 ▶

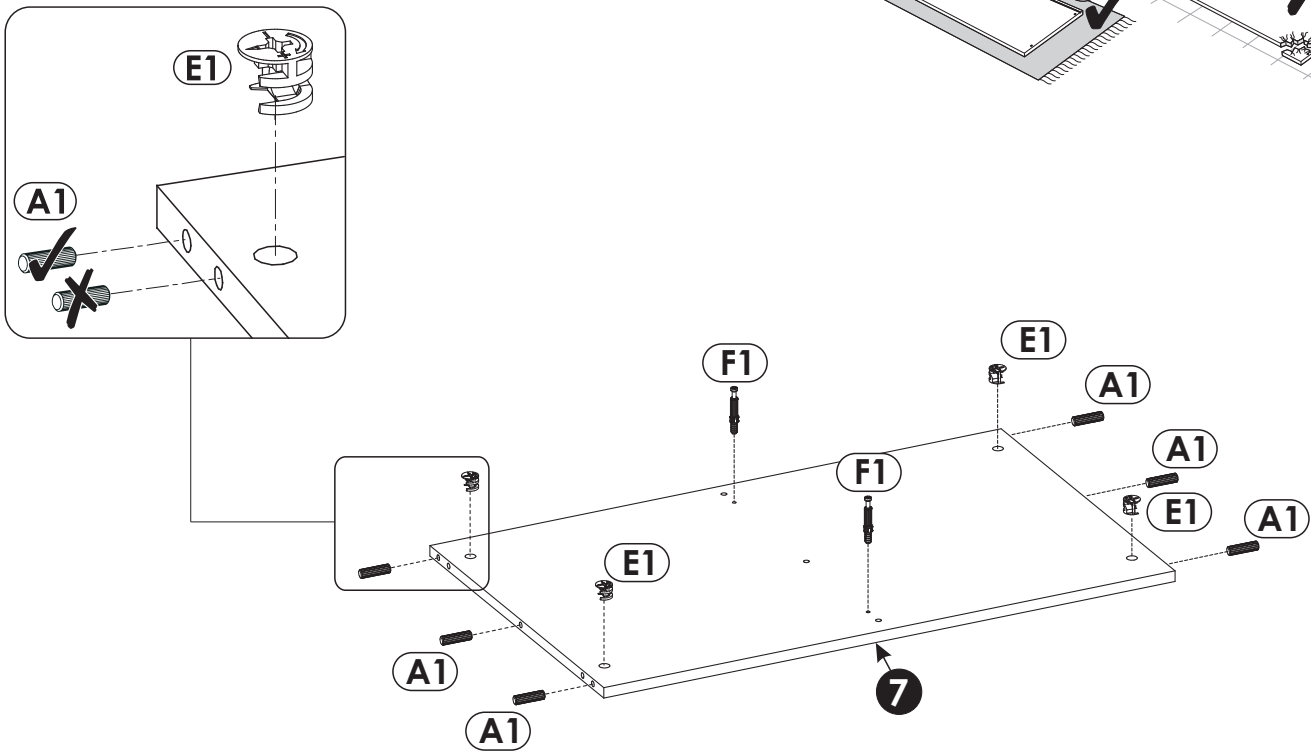

3 ▶

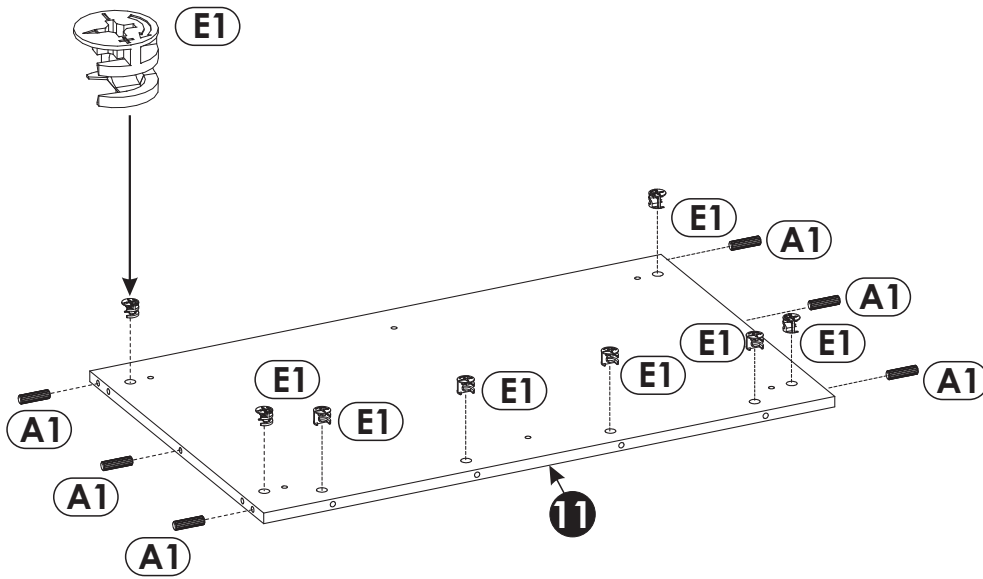
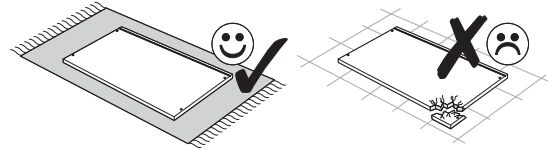

4 ▶

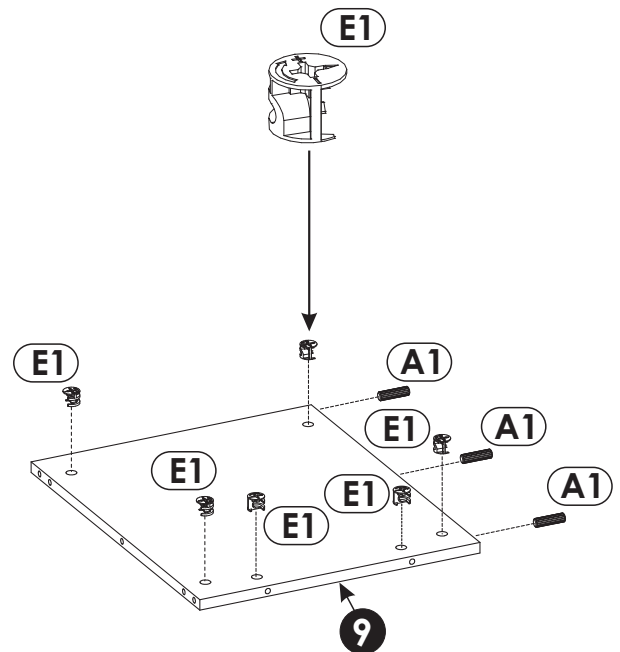
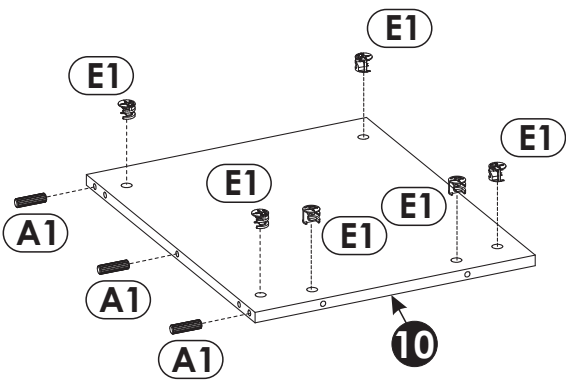
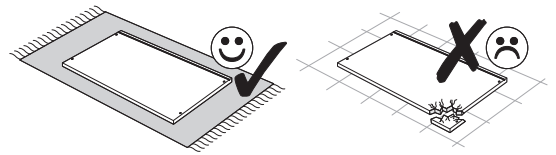

5 ▶

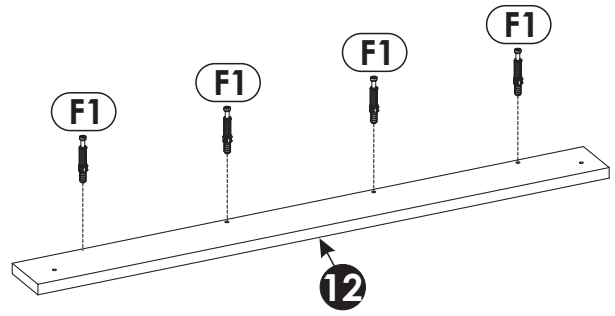
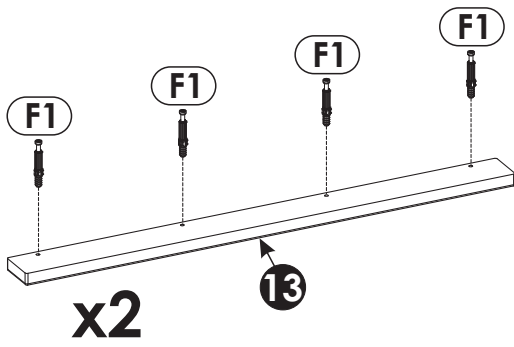
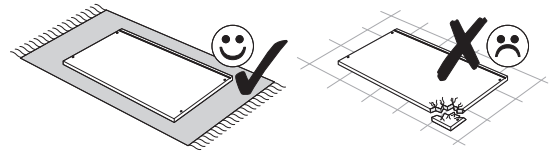

6 ▶

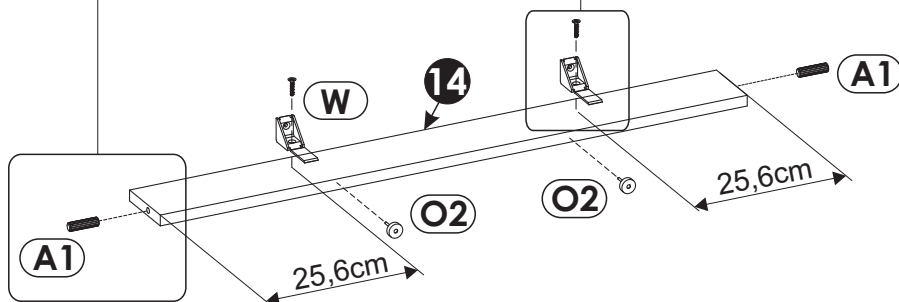
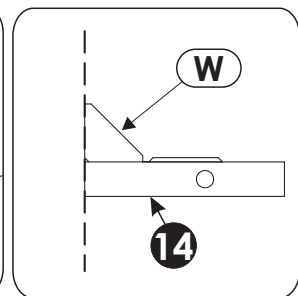
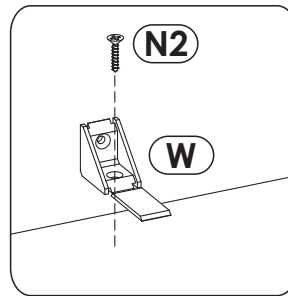
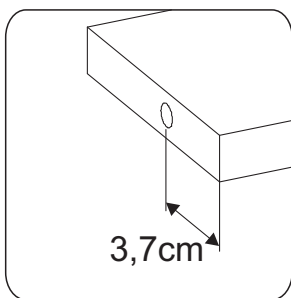
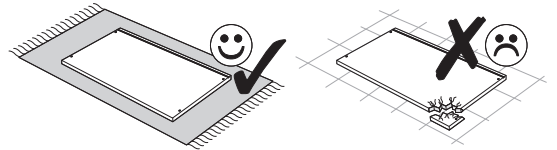

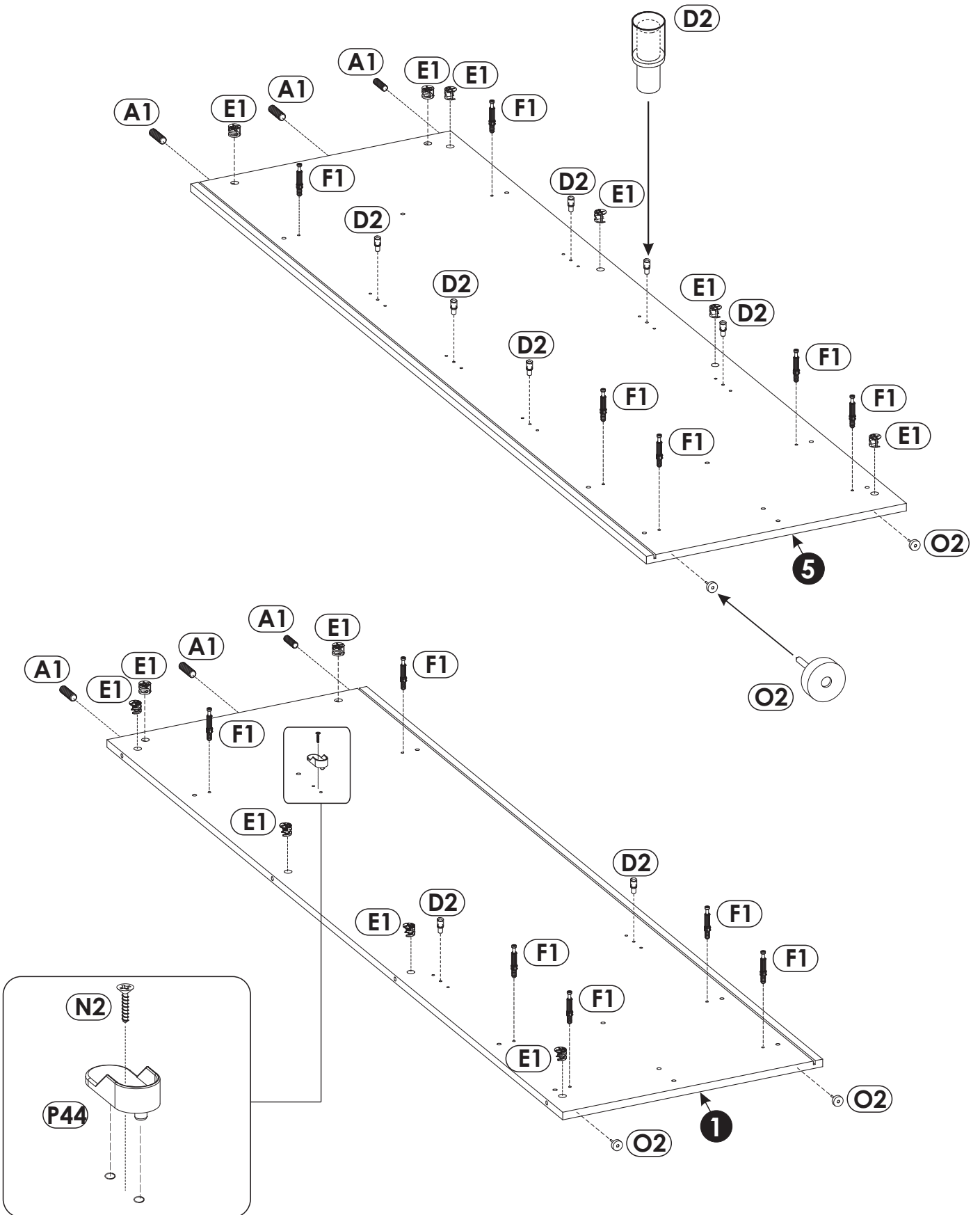
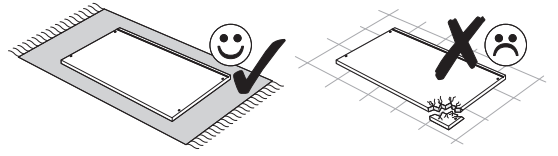

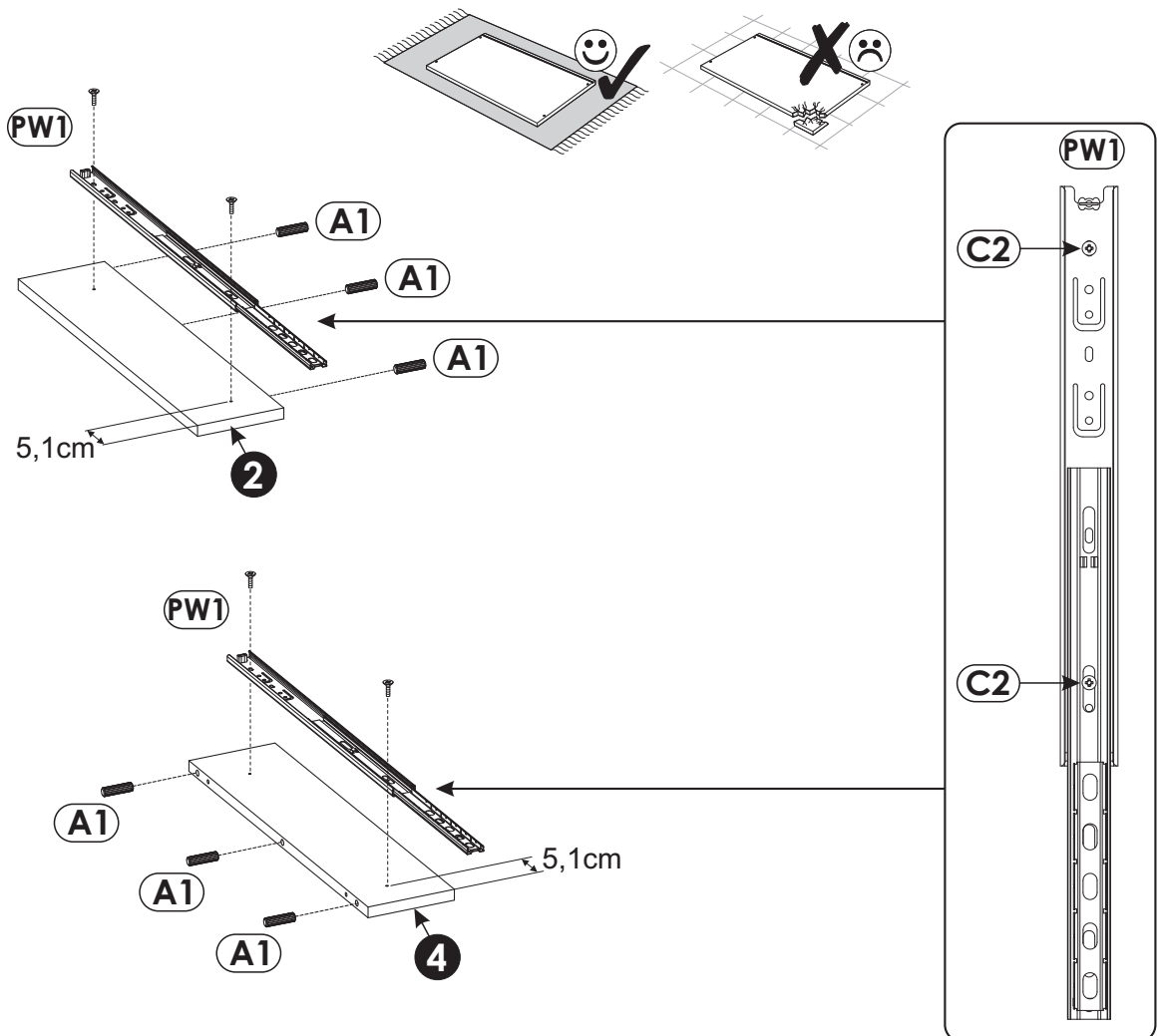
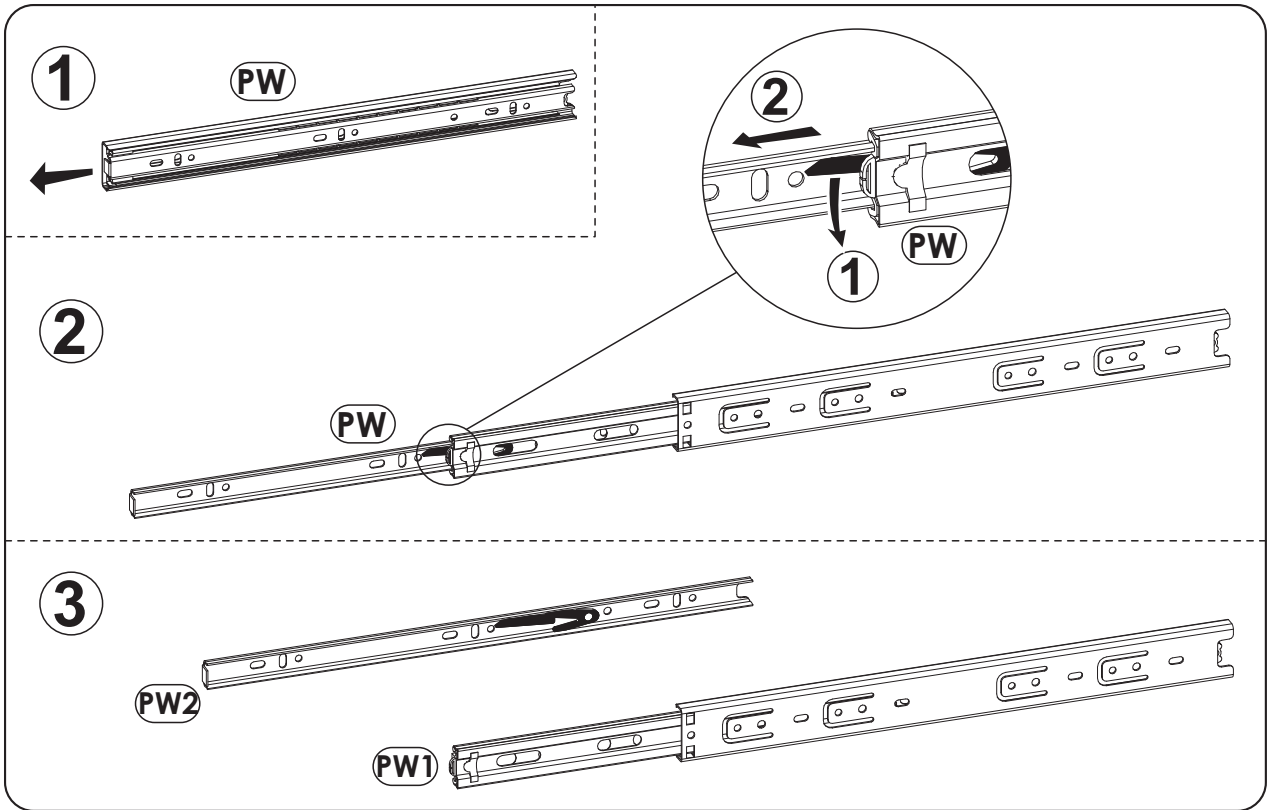

9 ▶

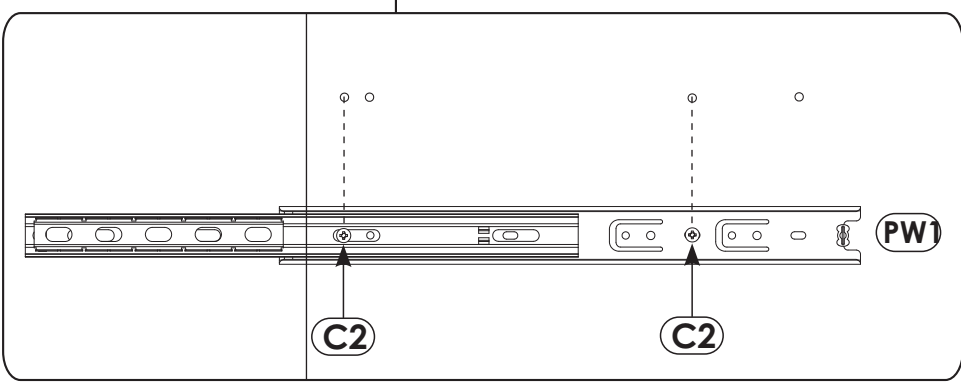
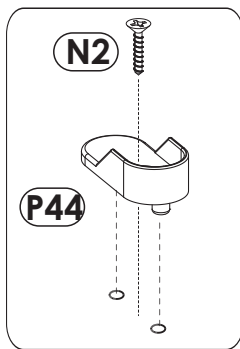
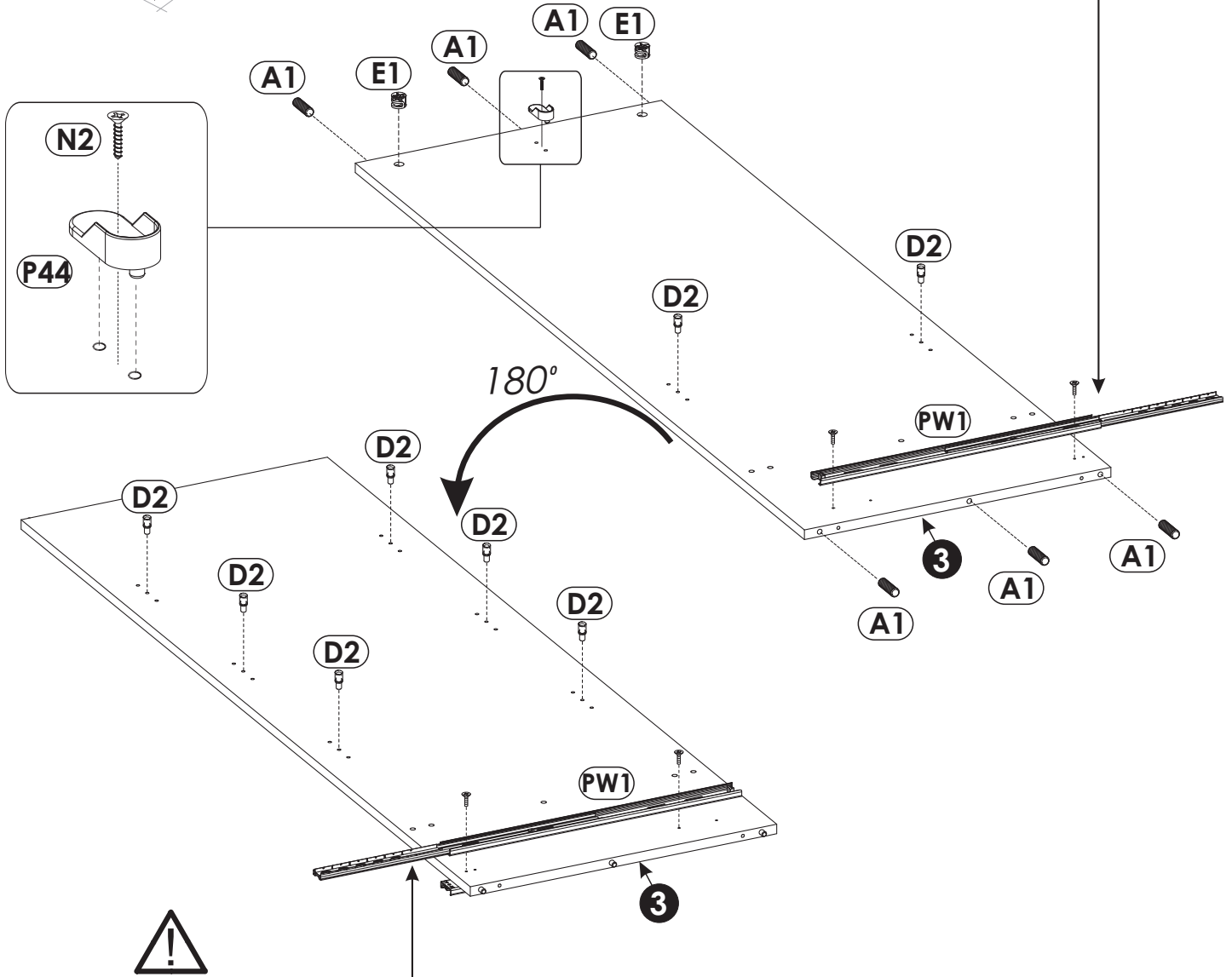
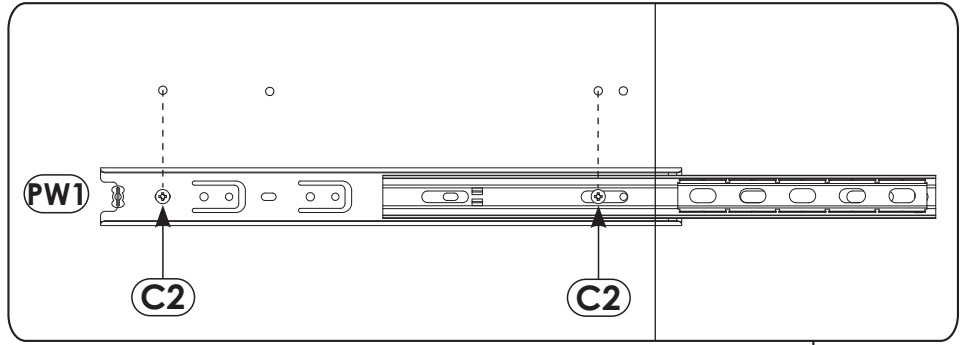
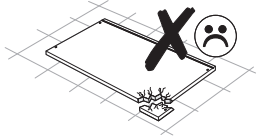
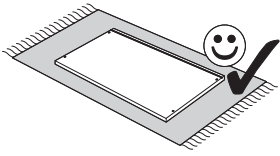

10 ▶

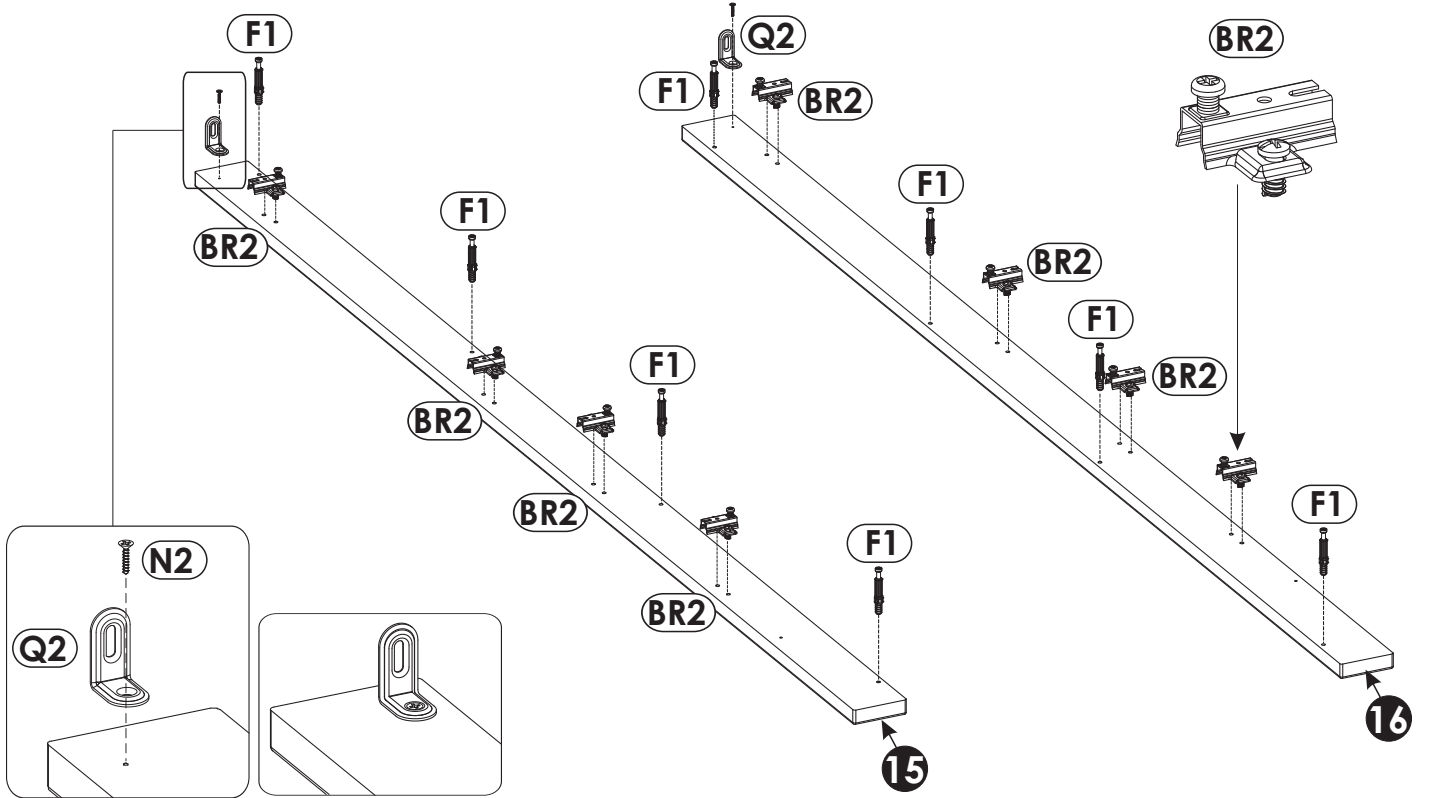
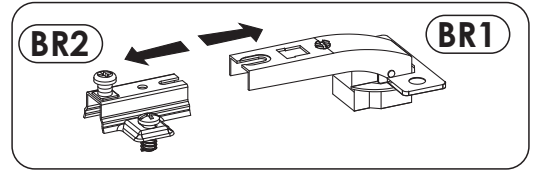
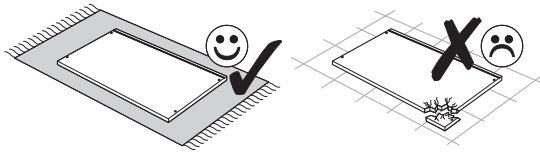

11 ▶

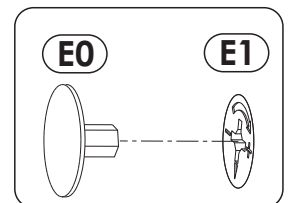
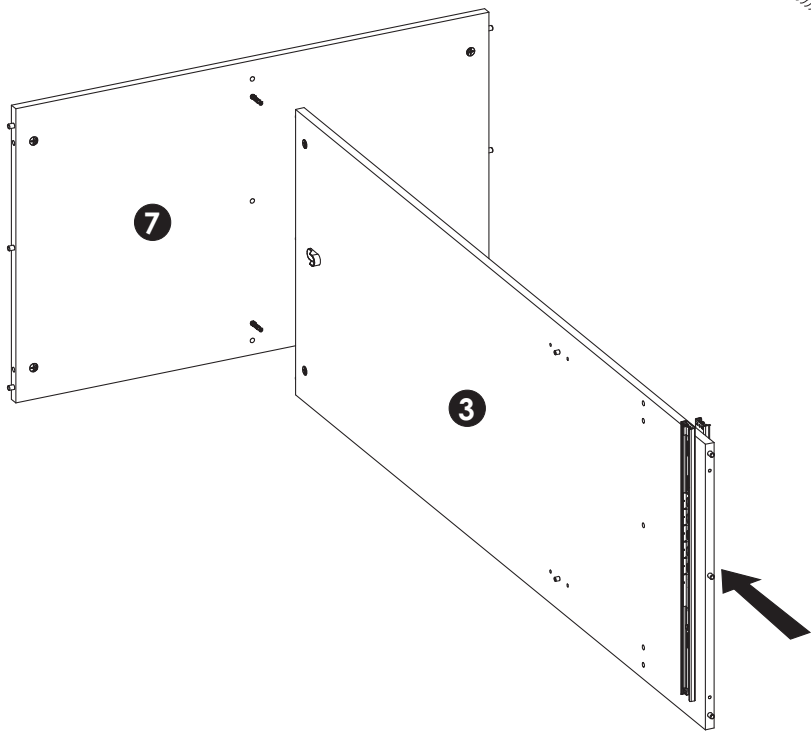
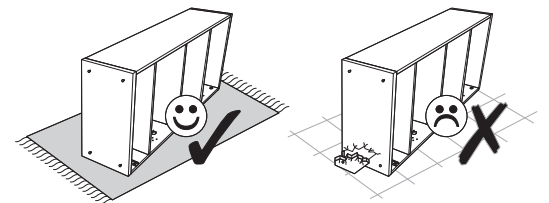

12▶

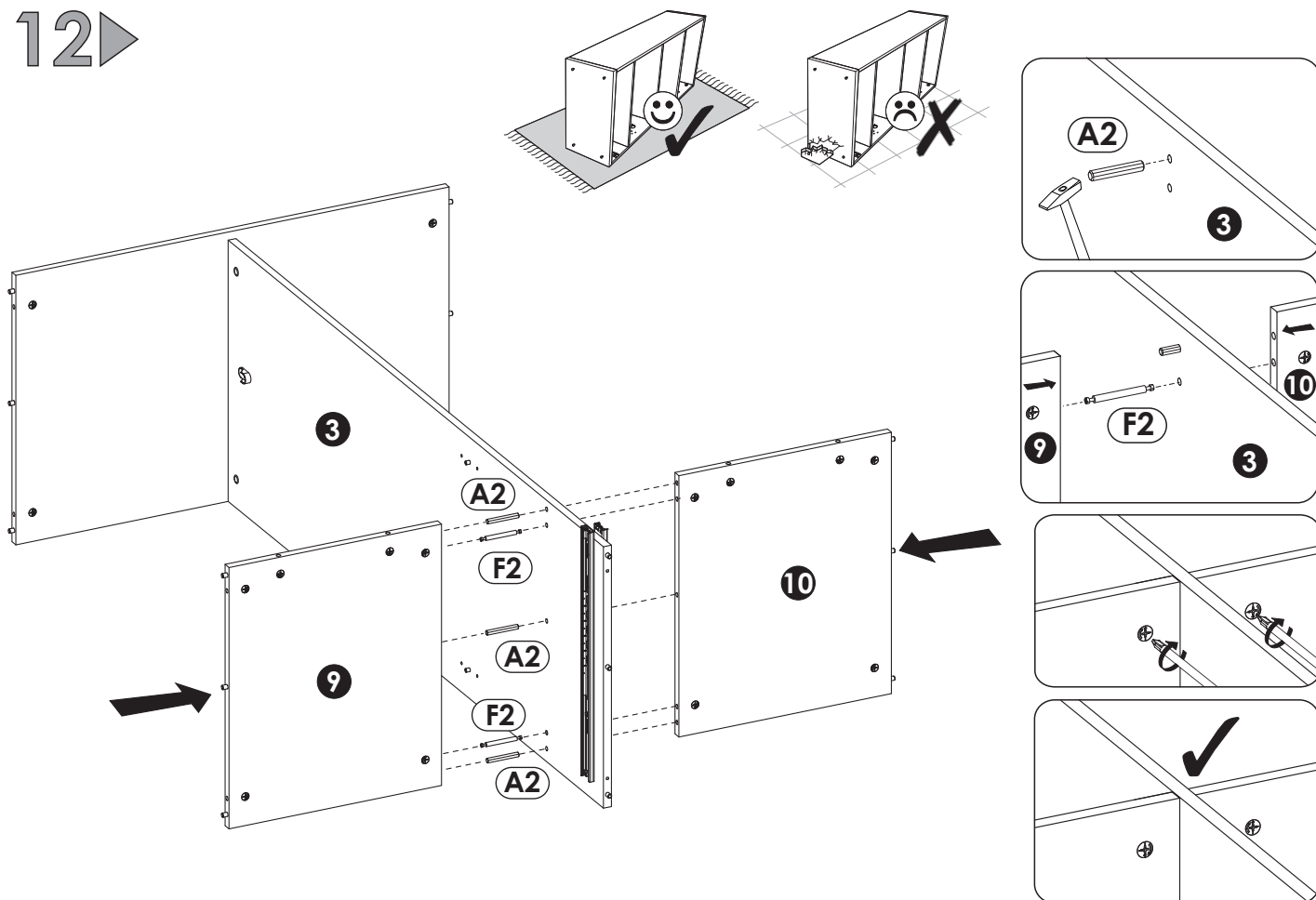

13▶

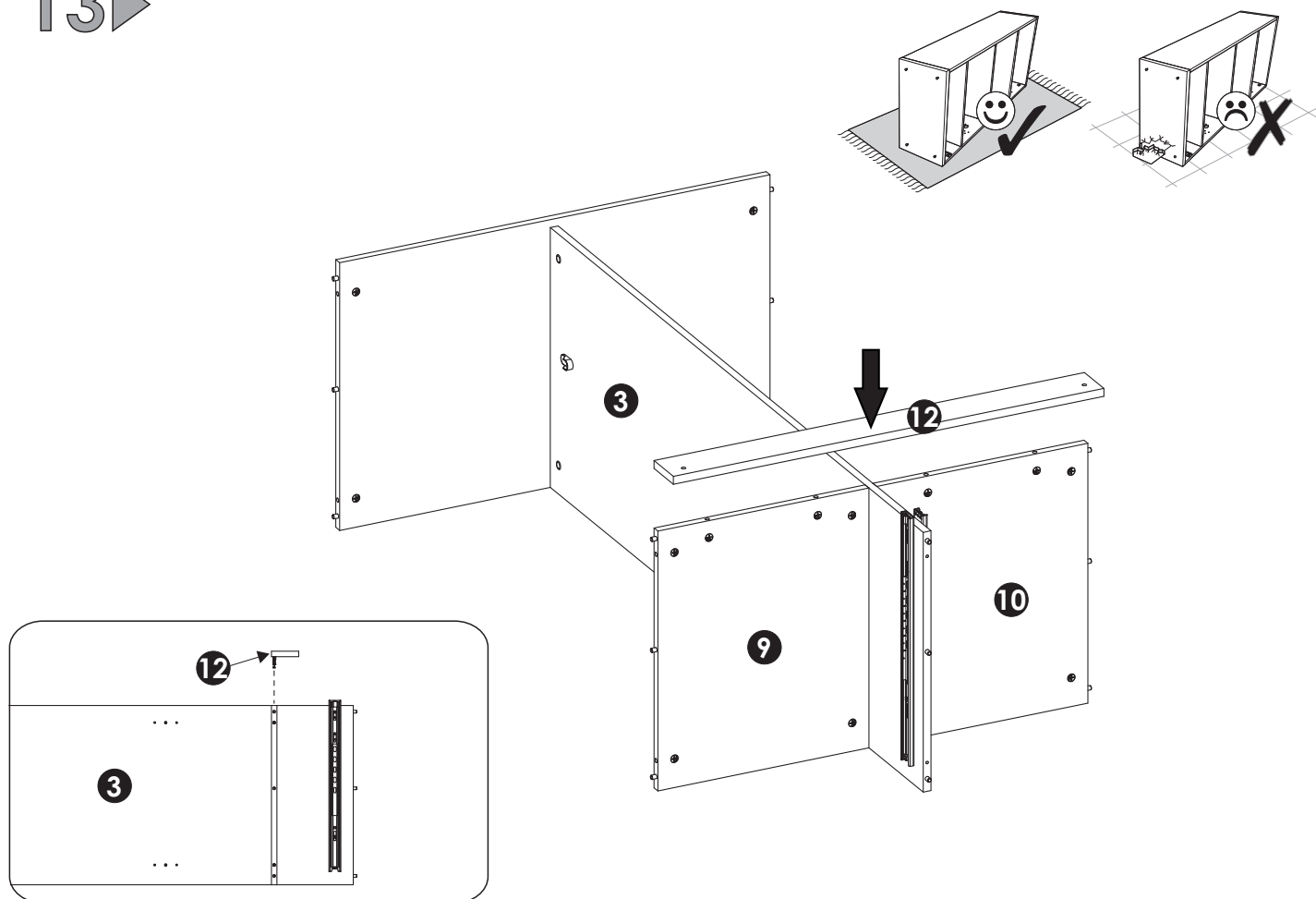

14 ▶

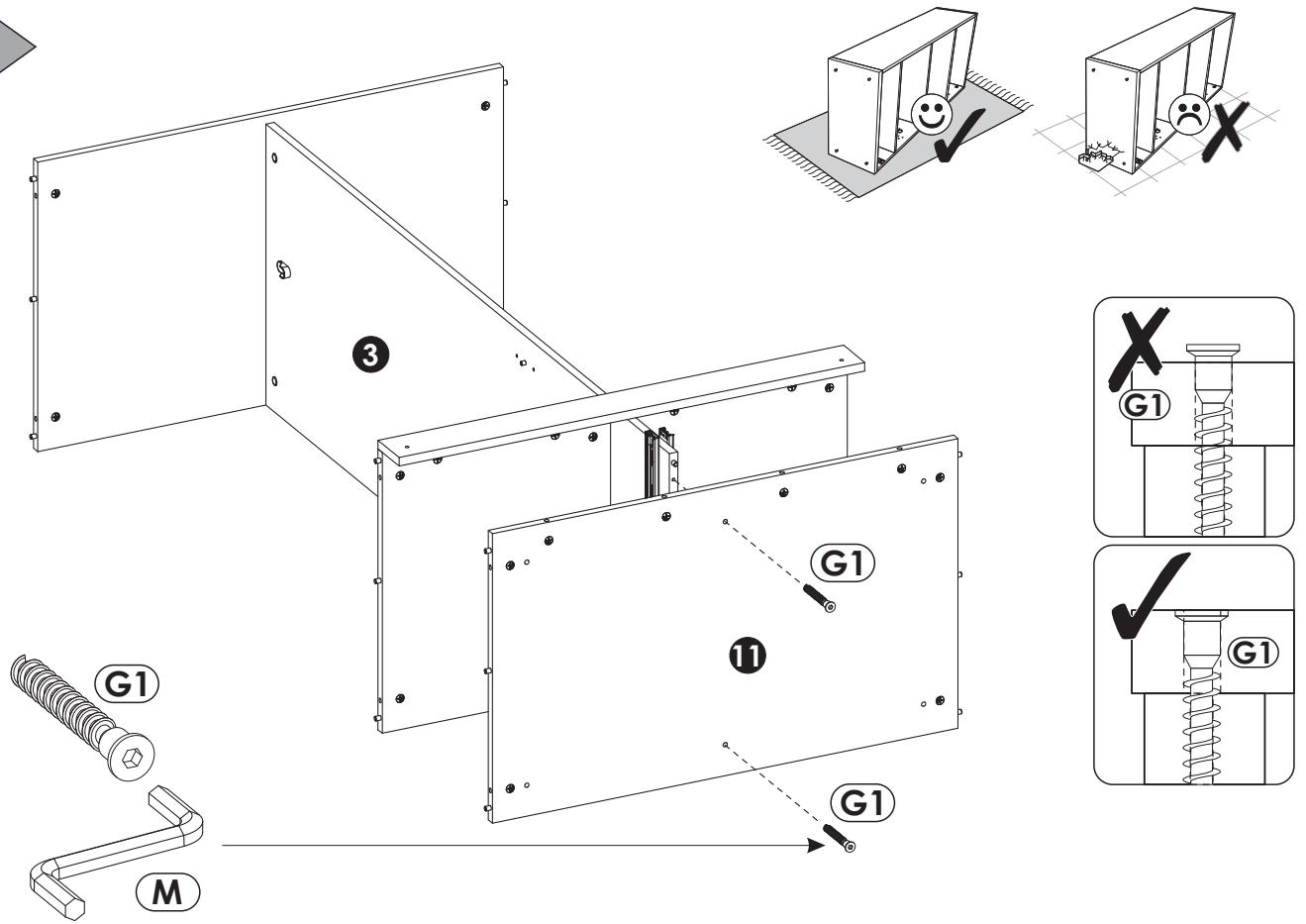

15 ▶

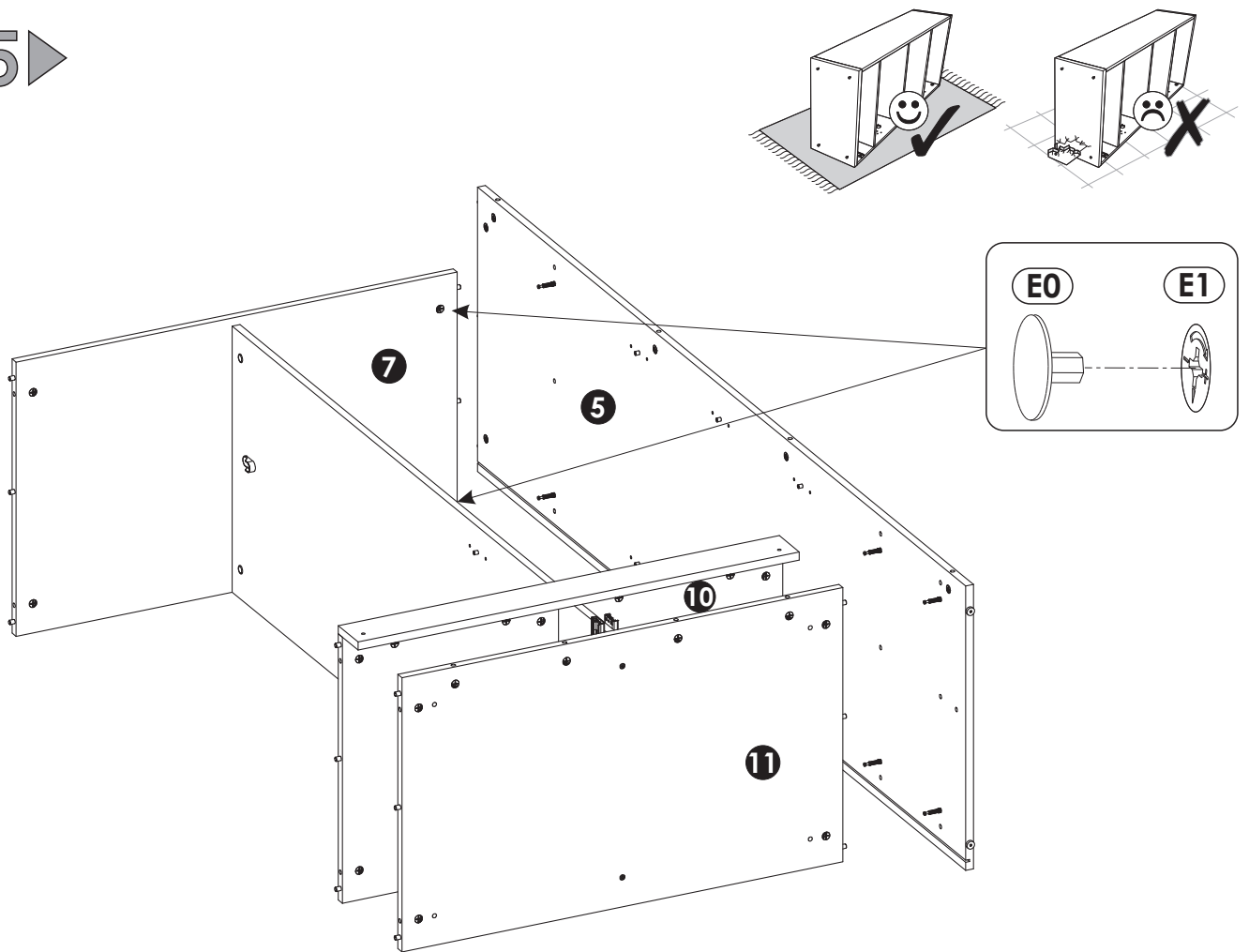

16 ▶

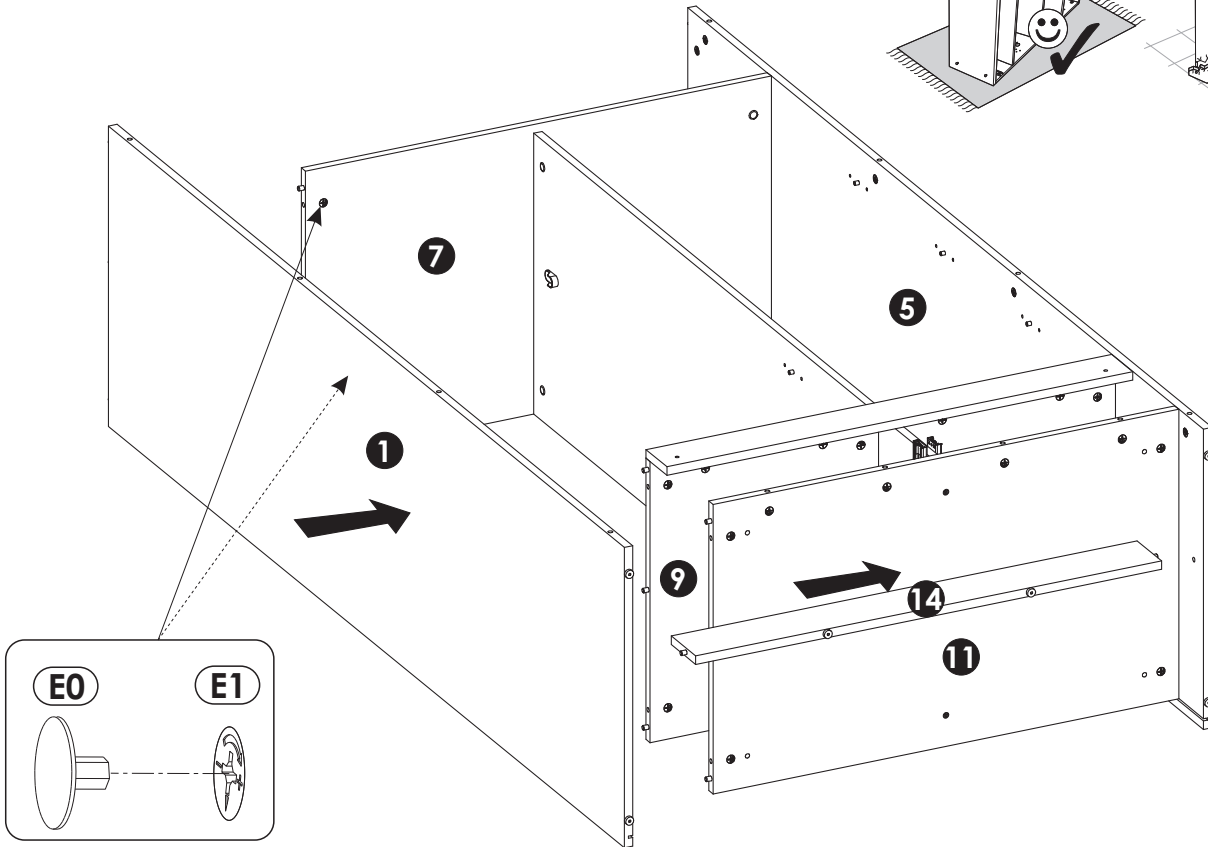
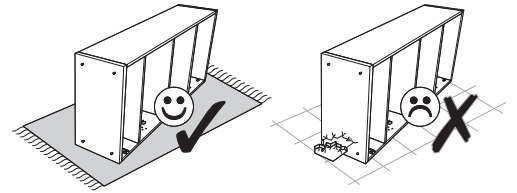

17 ▶

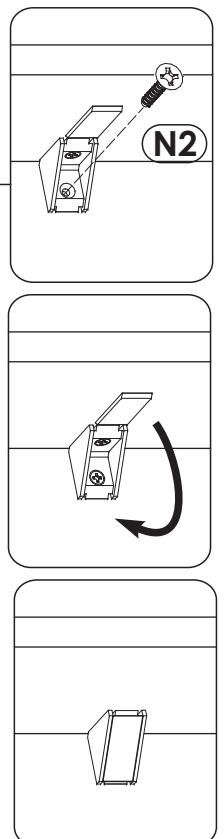
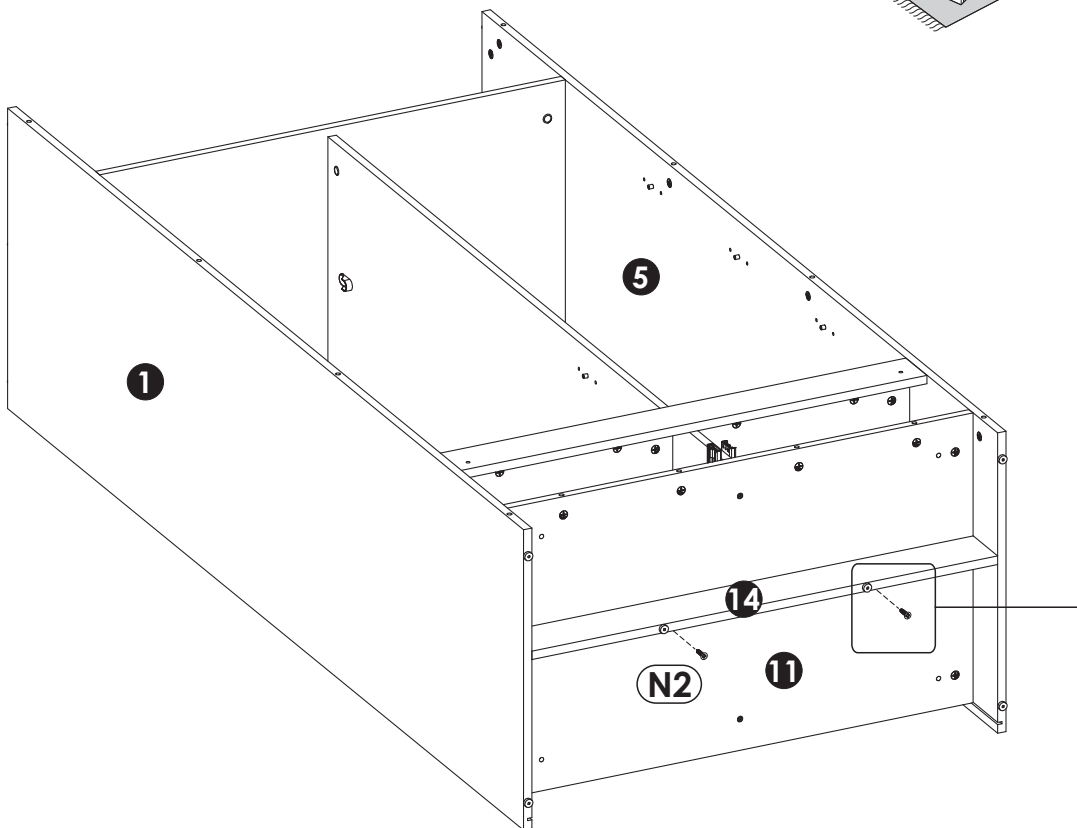
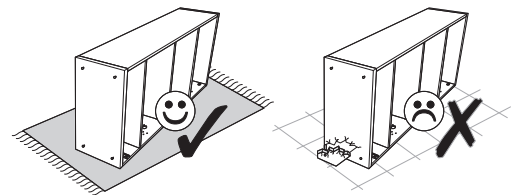

18 ▶

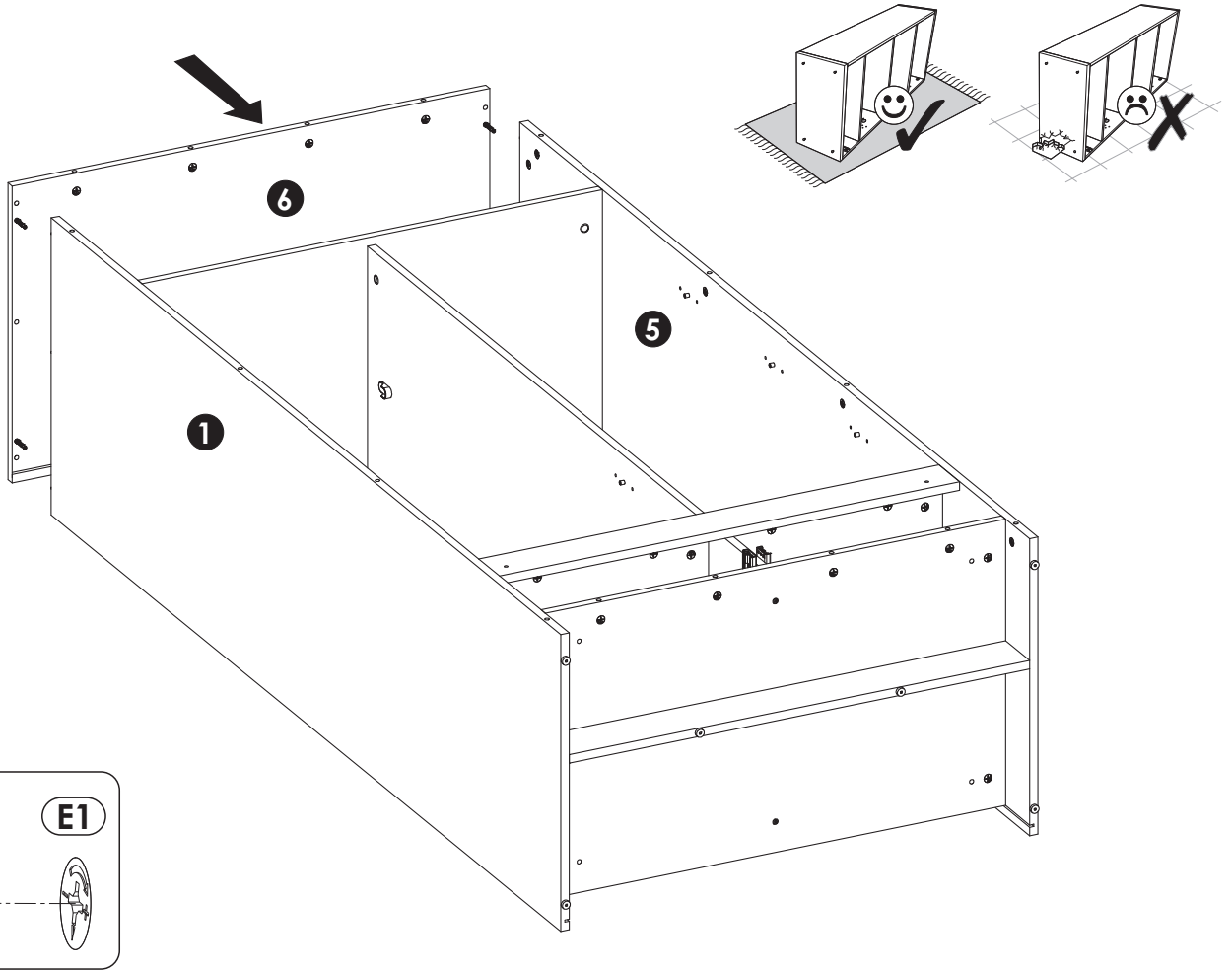

19 ▶

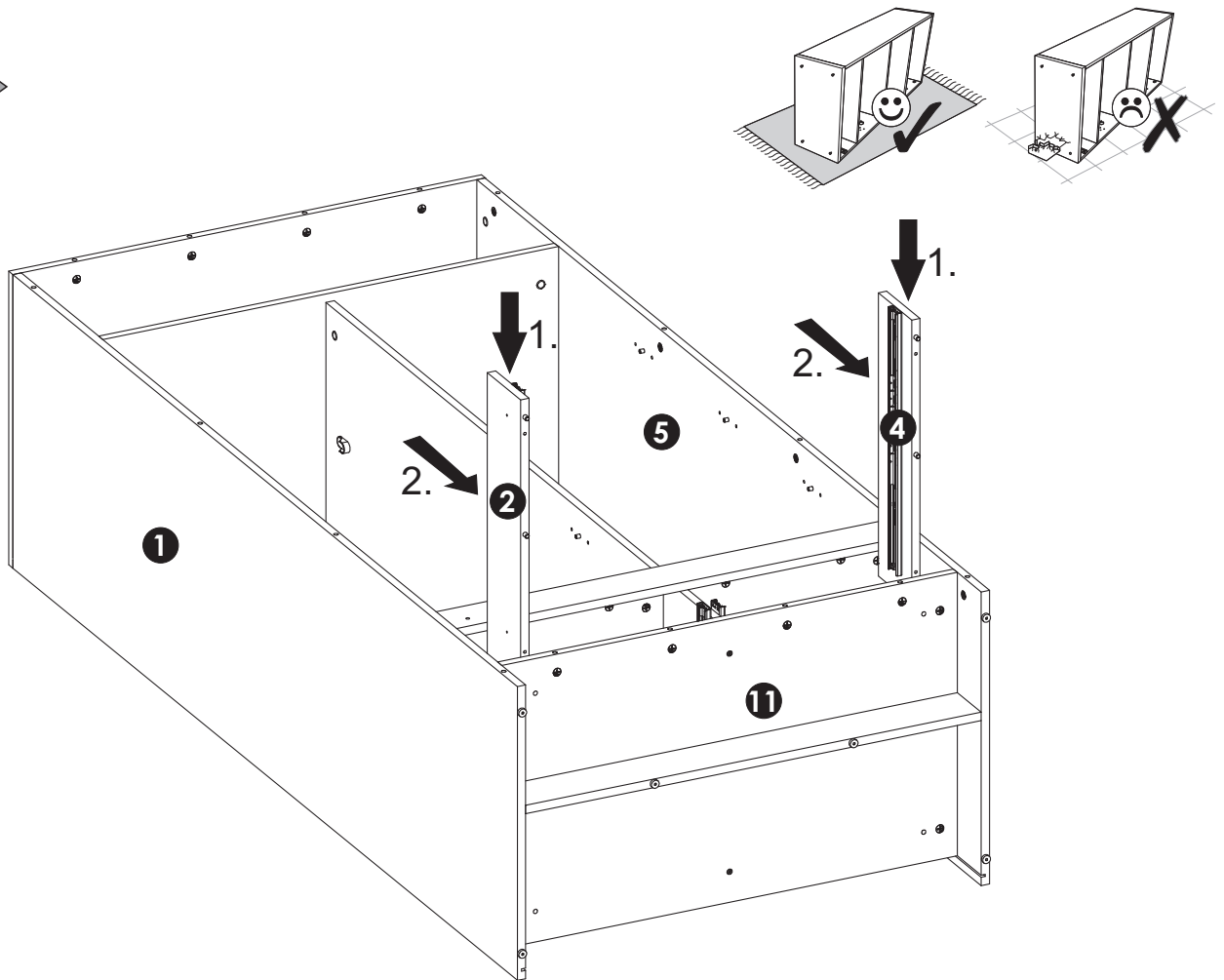

20 ▶

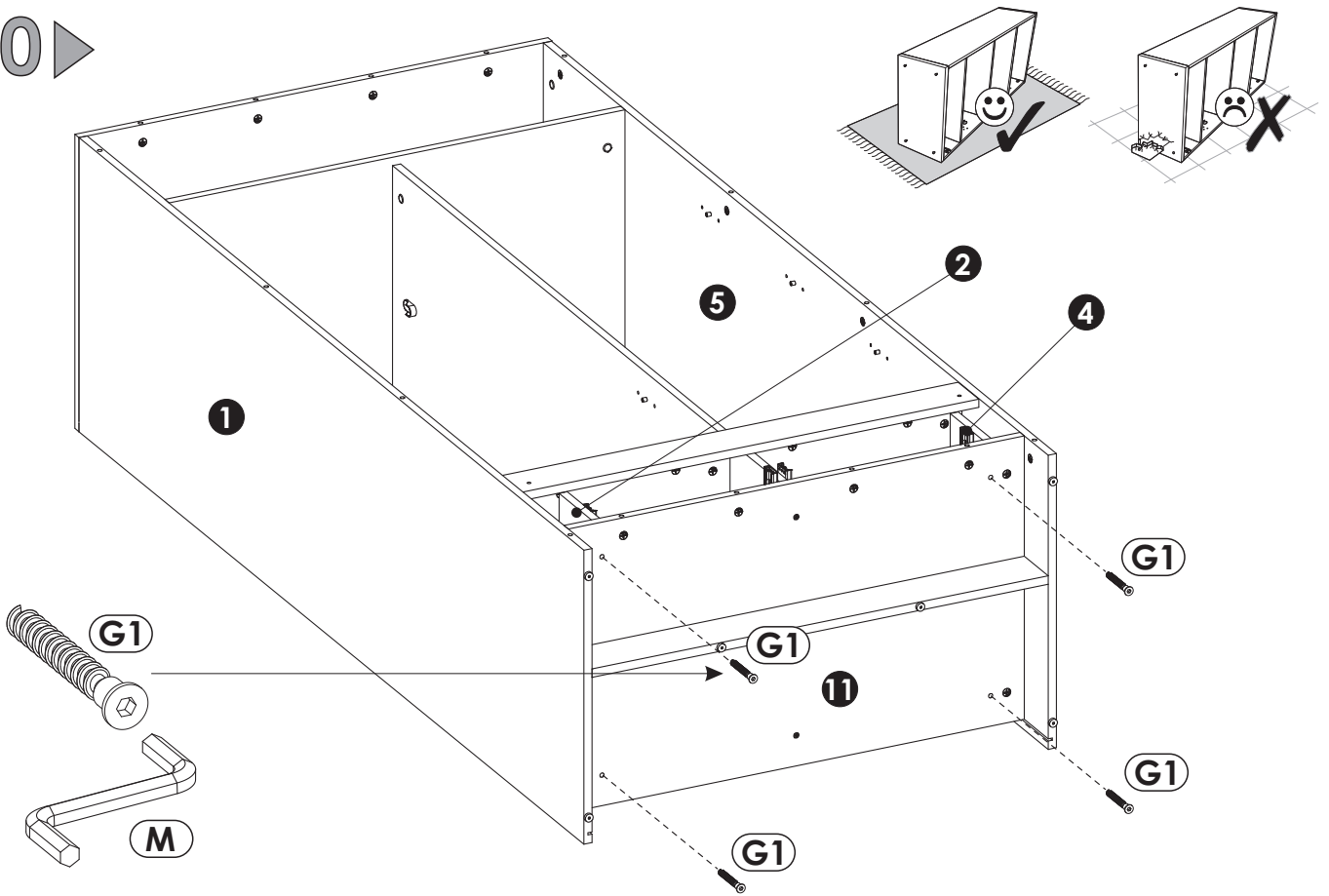

21 ▶

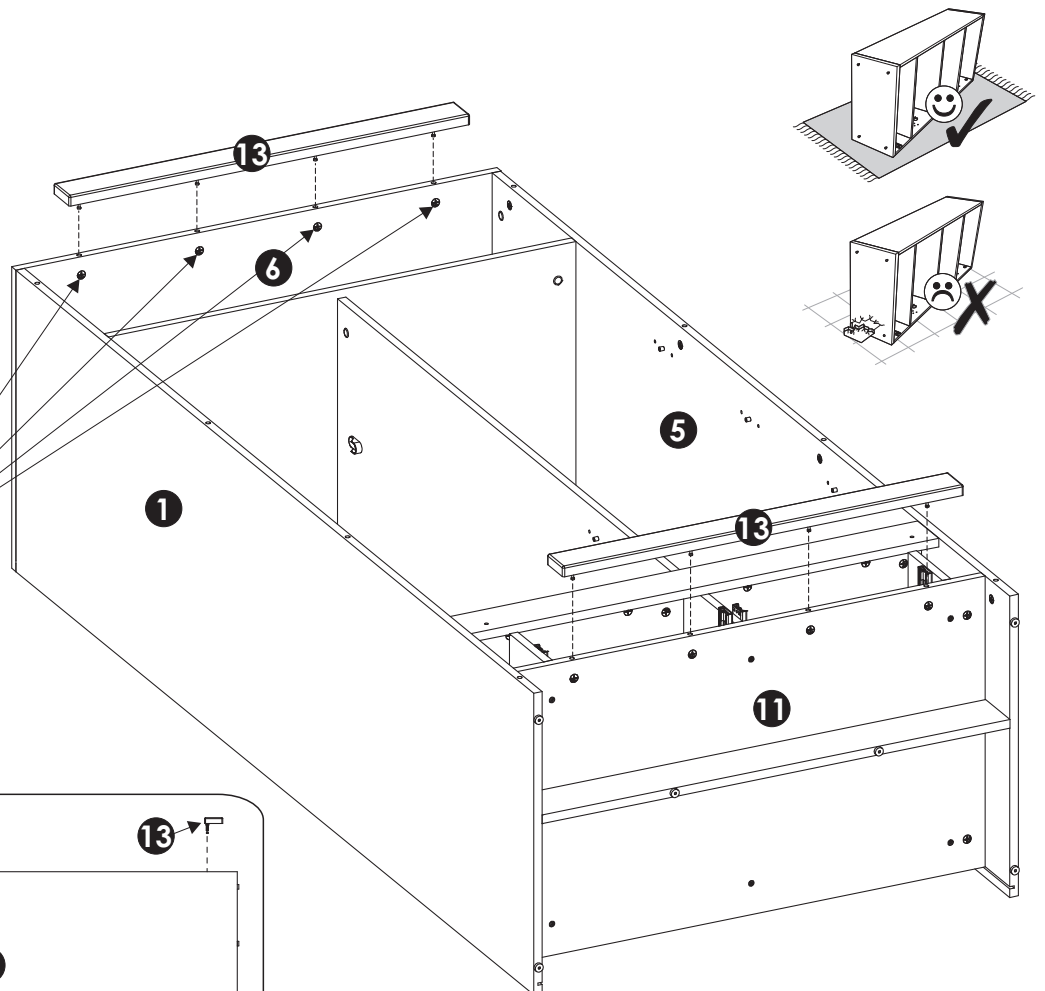
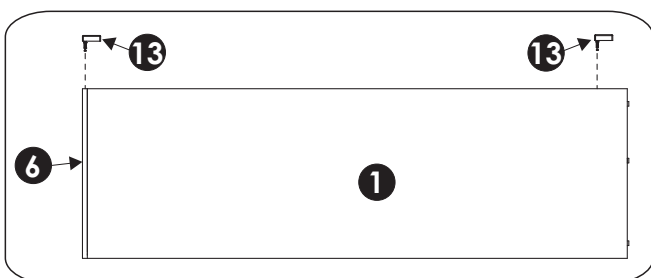
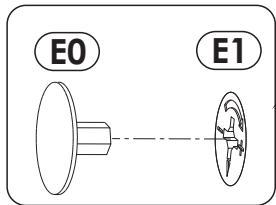
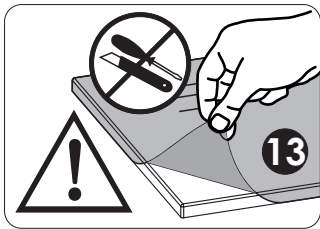

22 ▶

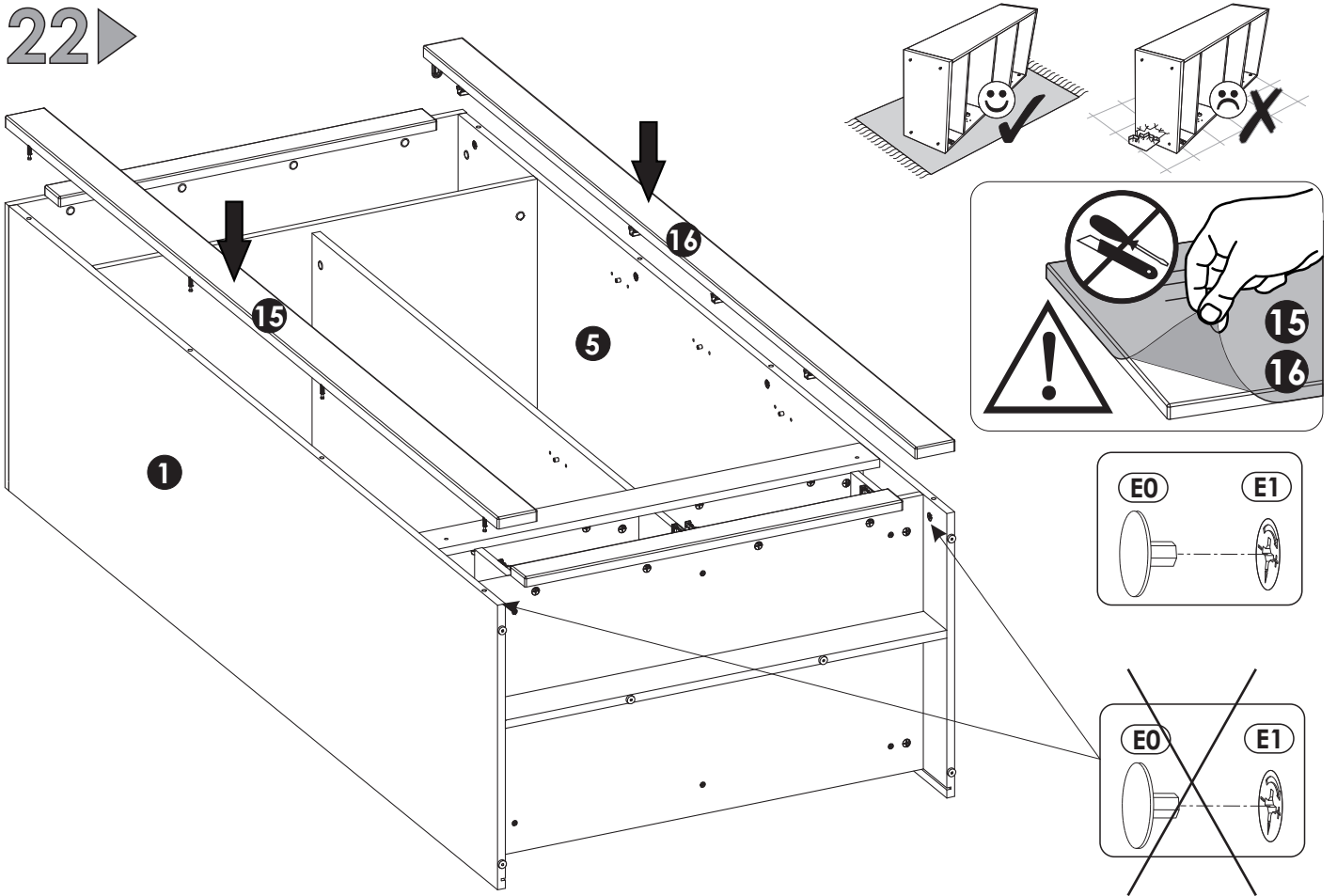

23 ▶

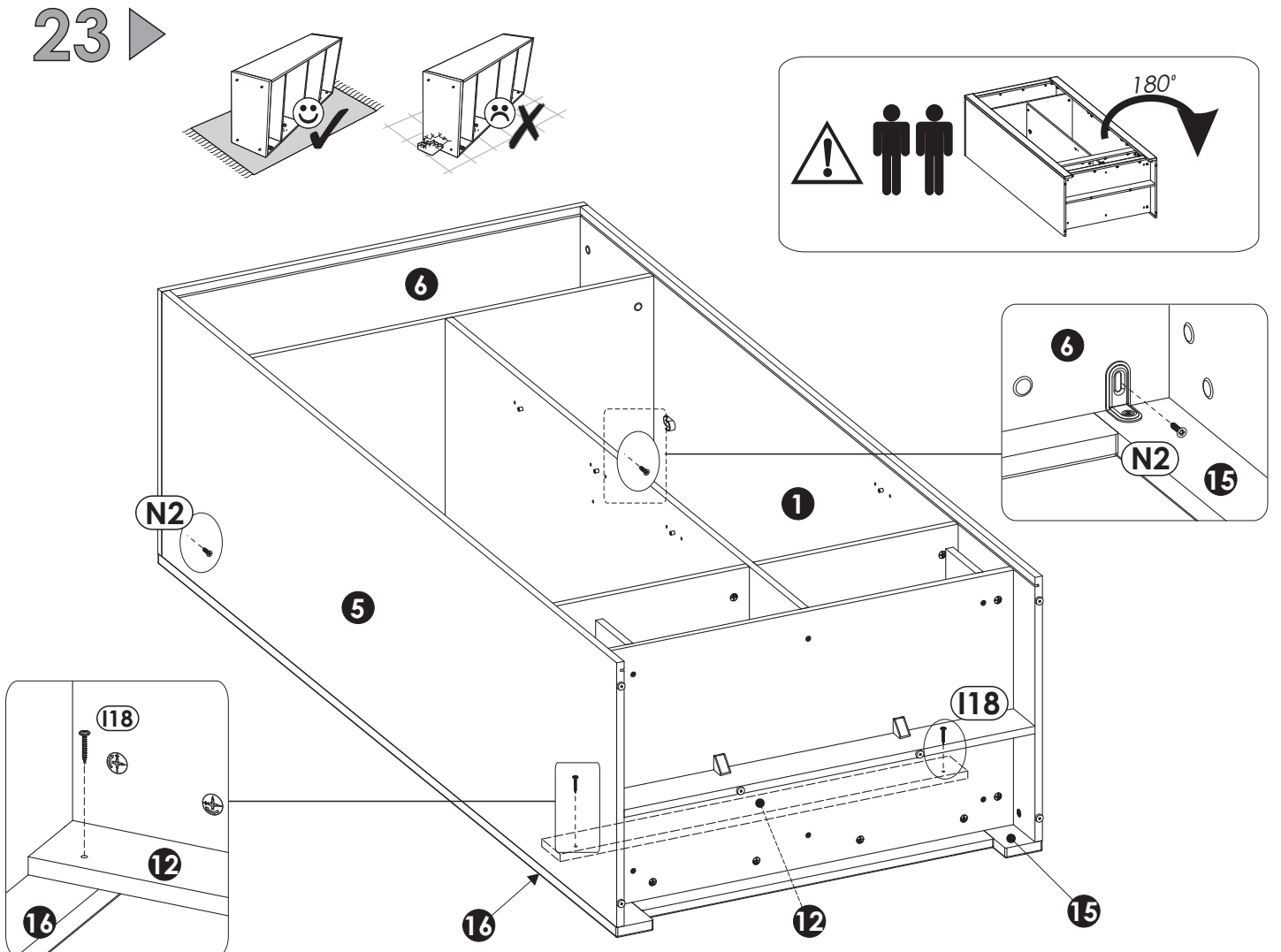

24 ▶

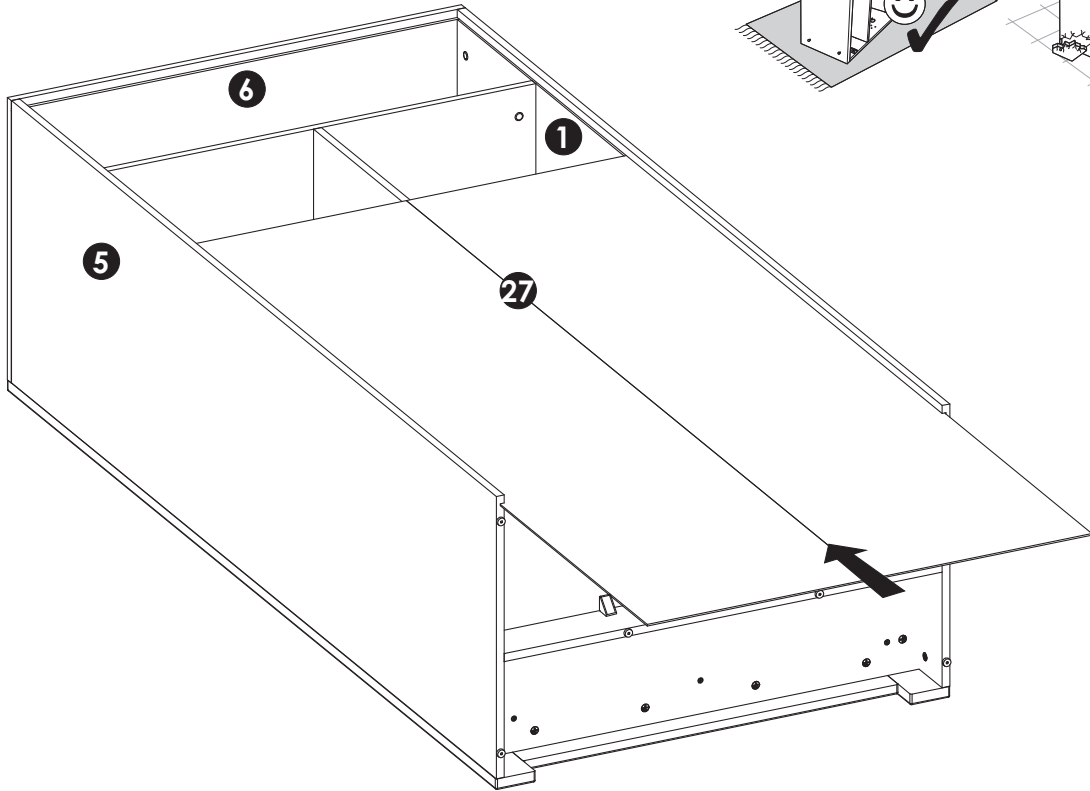

25 ▶

$A=B$

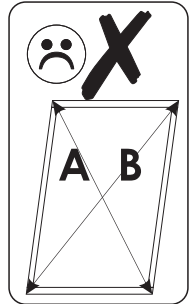
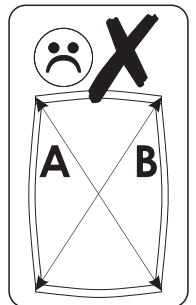
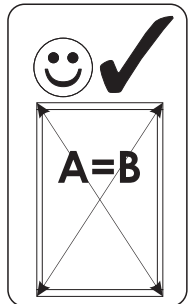
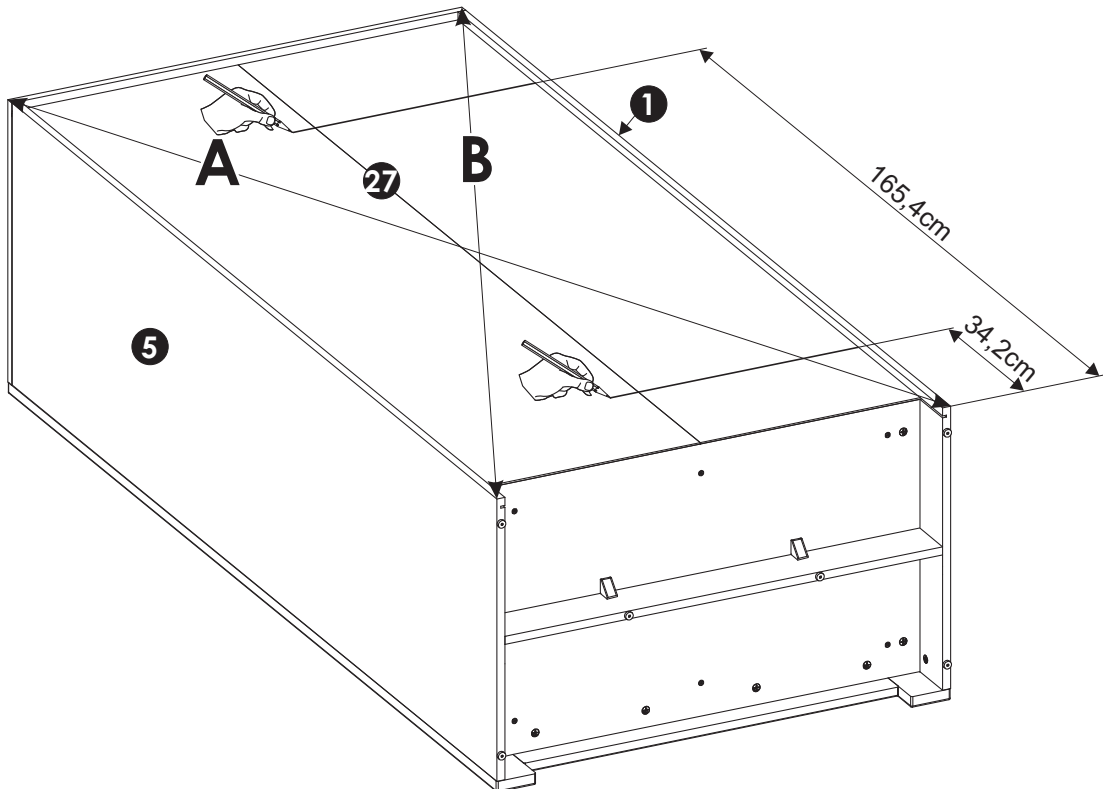
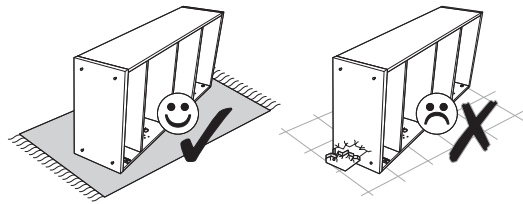

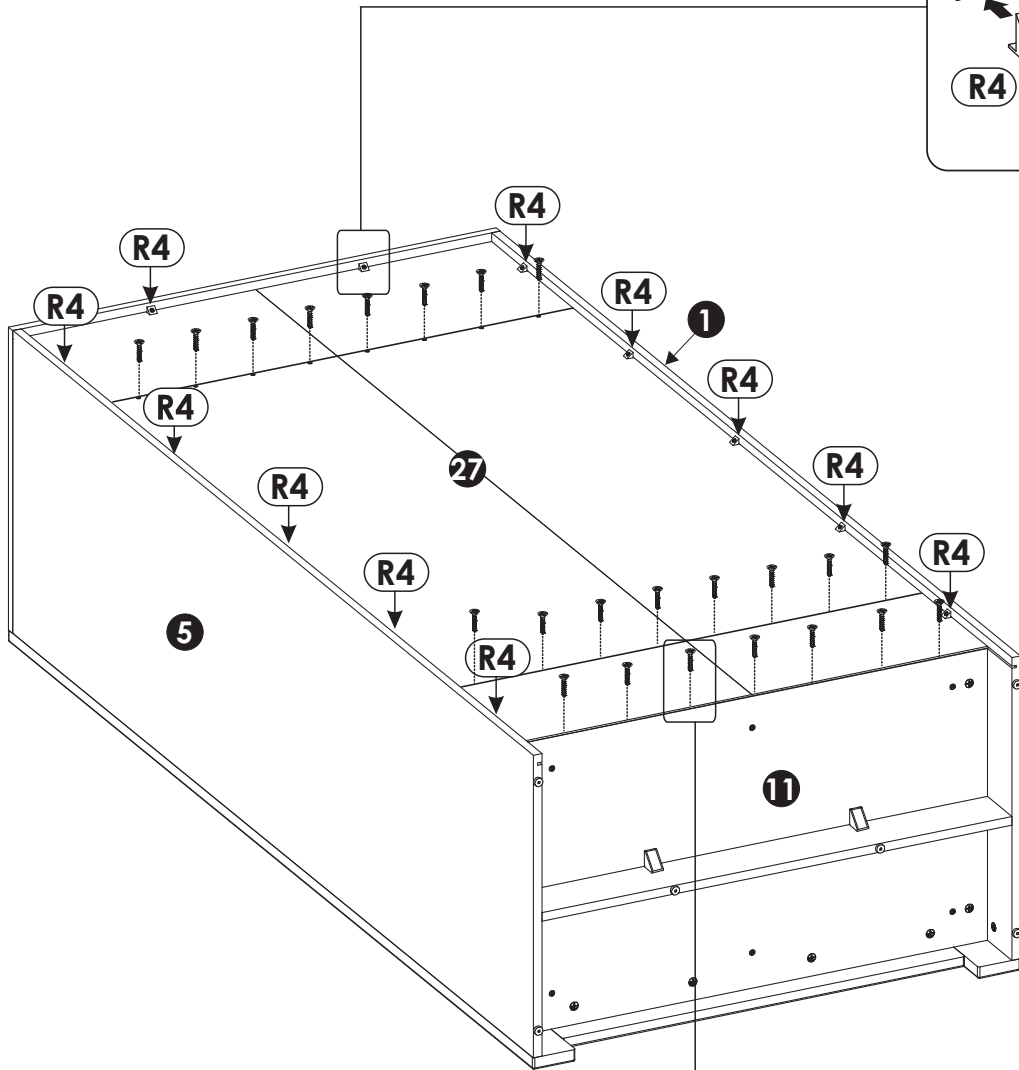
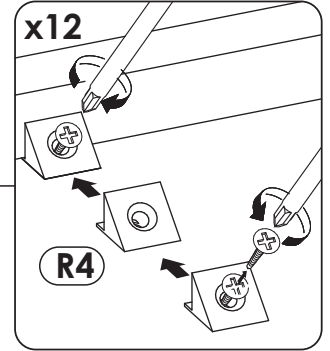
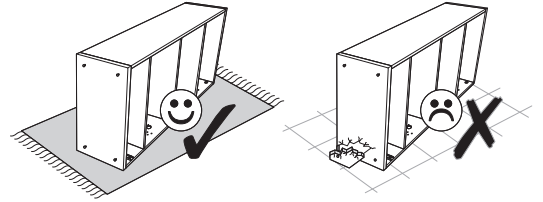

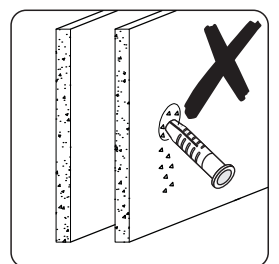
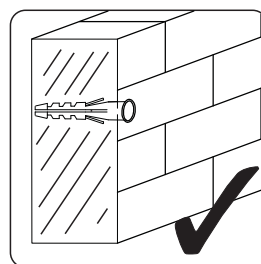
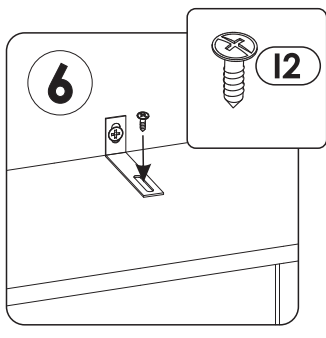
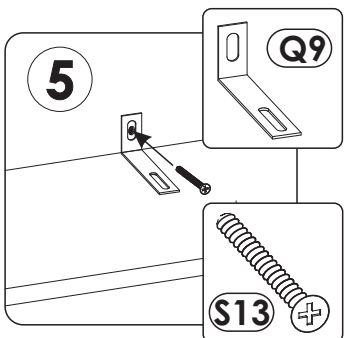
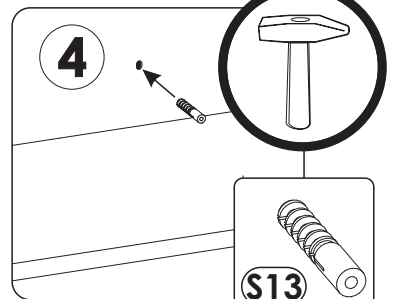
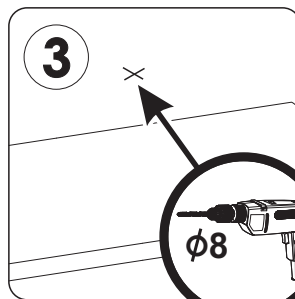
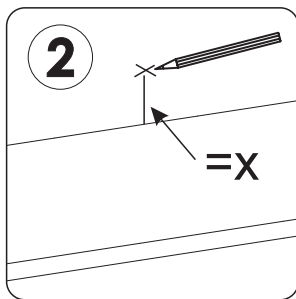
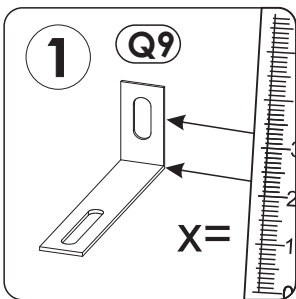
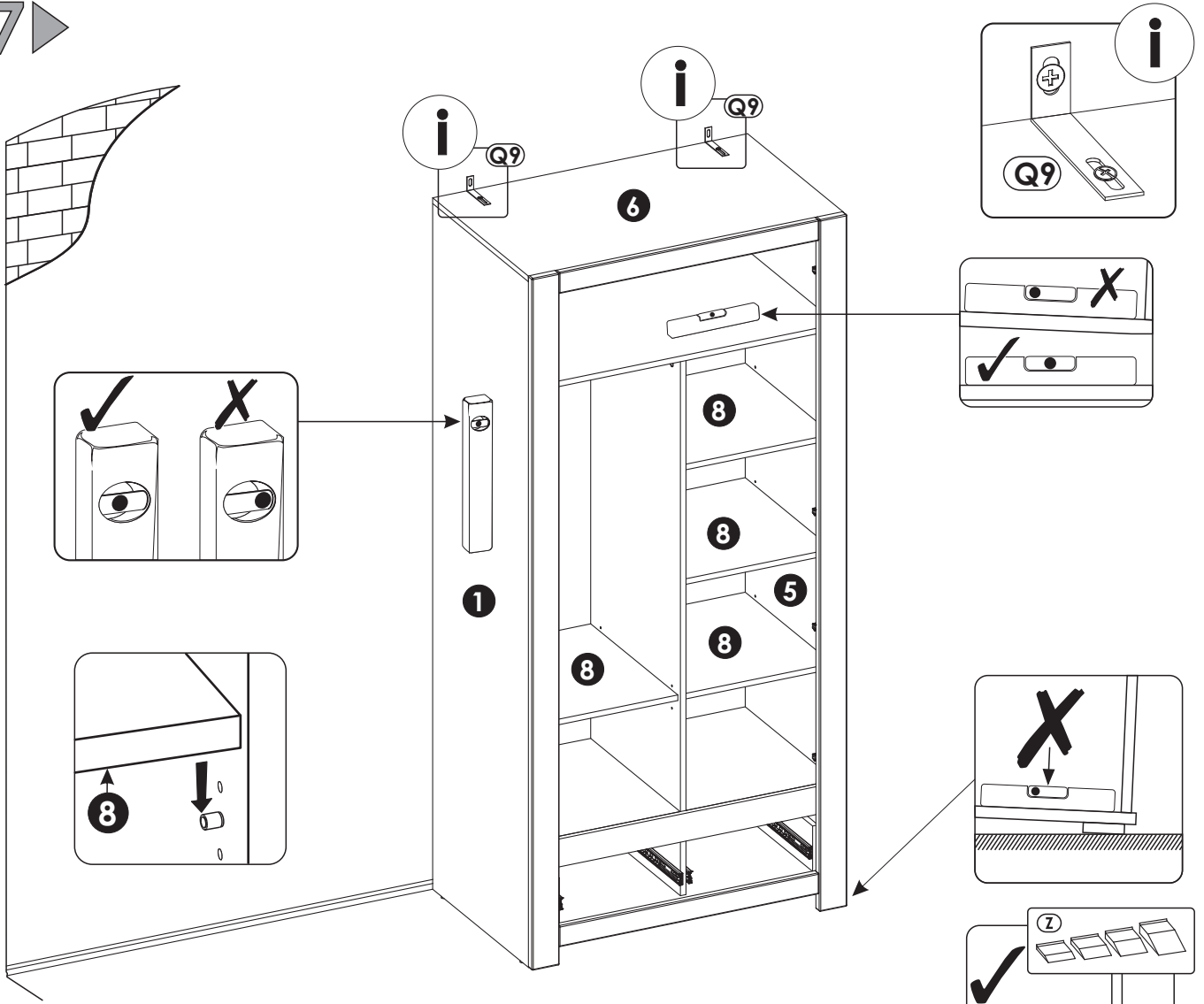

28 ▶

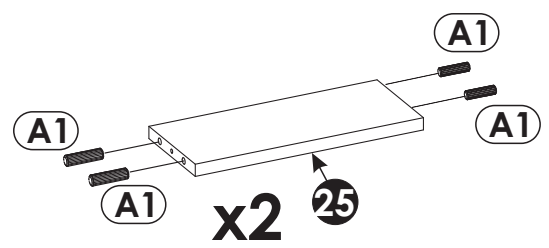
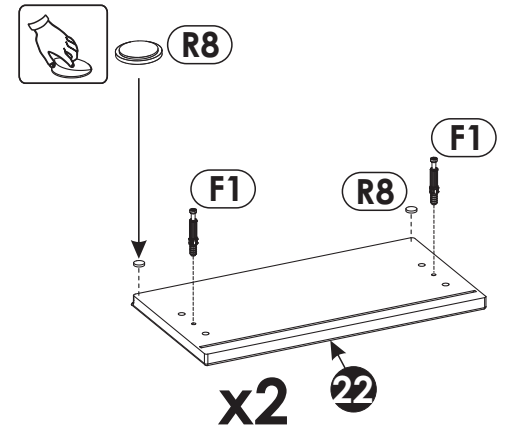
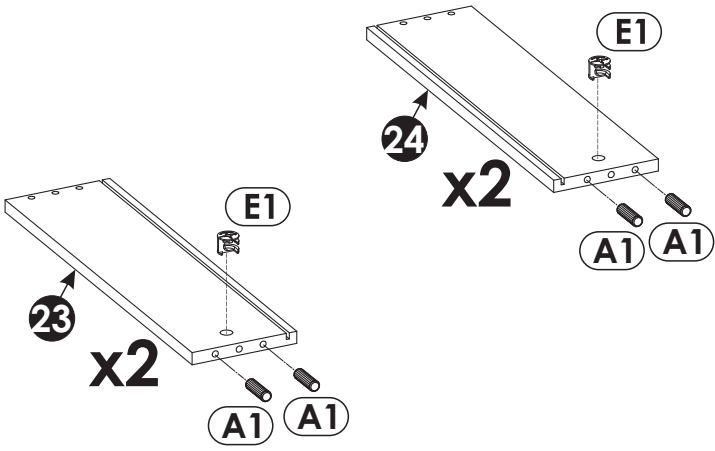
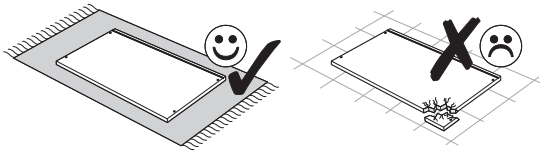

29 ▶

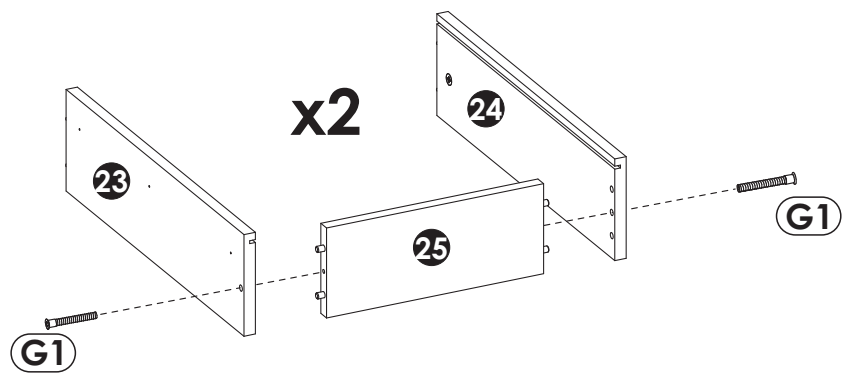
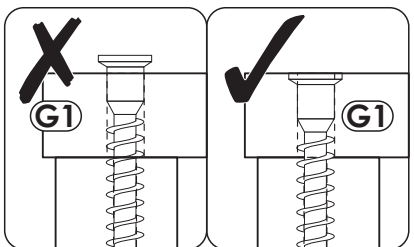
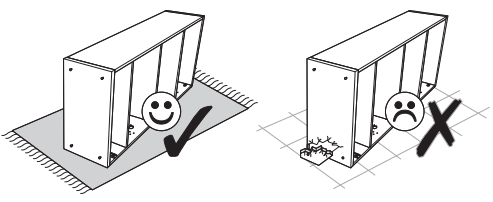

30 ▶

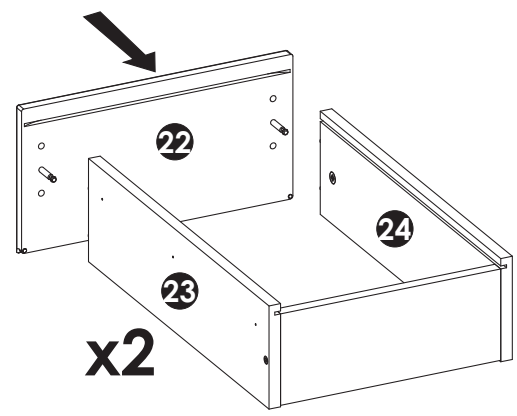
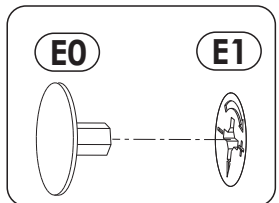
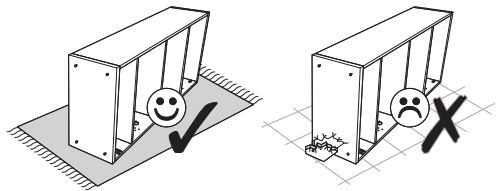

31 ▶

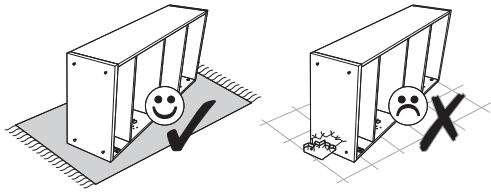

A=B

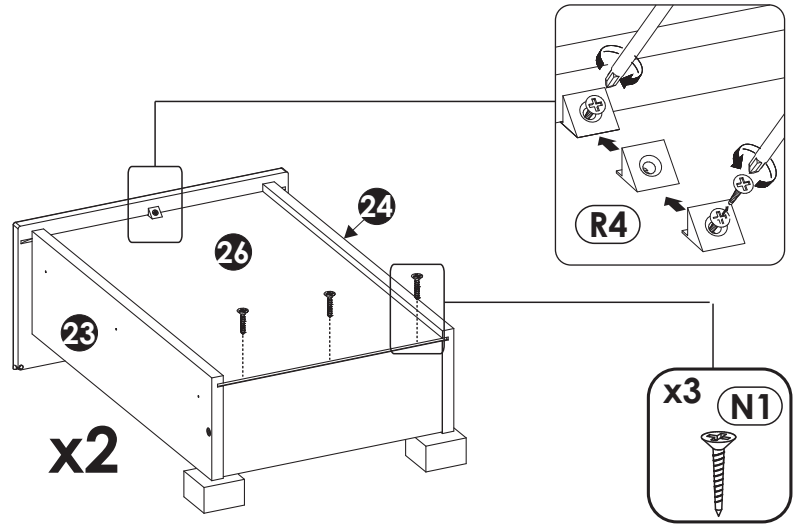
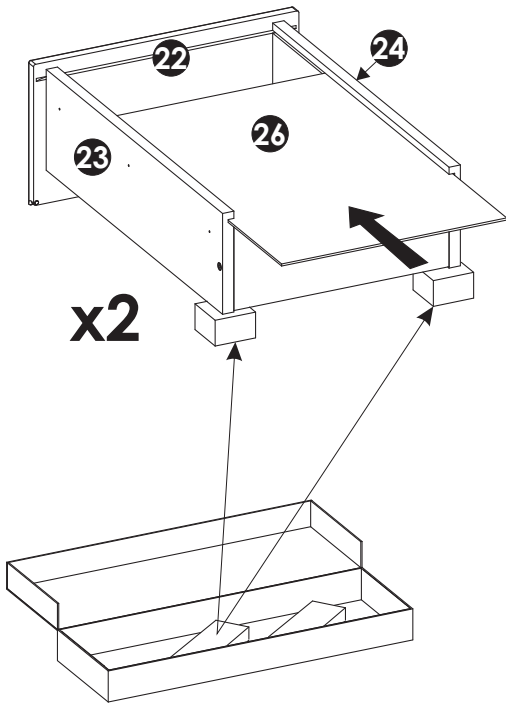
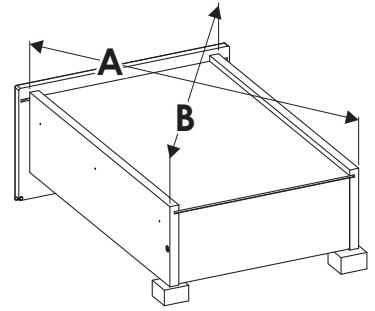

32 ▶

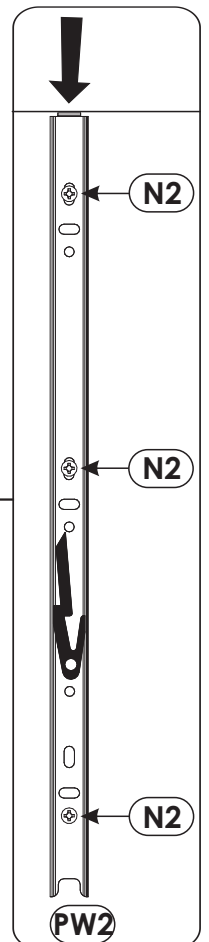
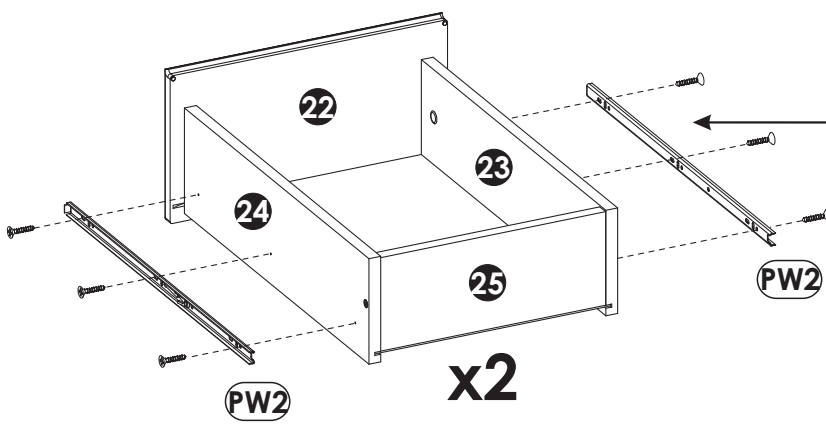
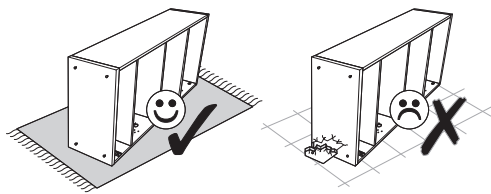

33 ▶

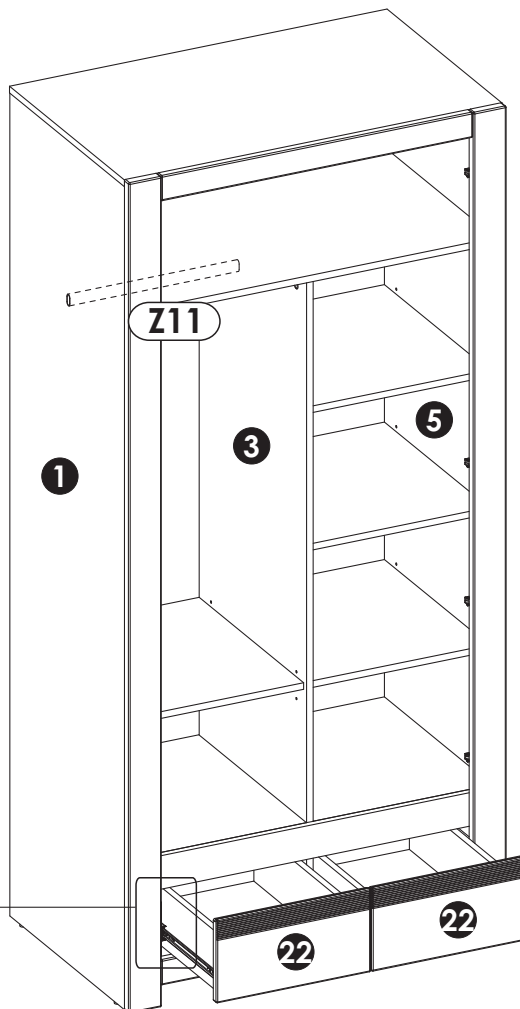
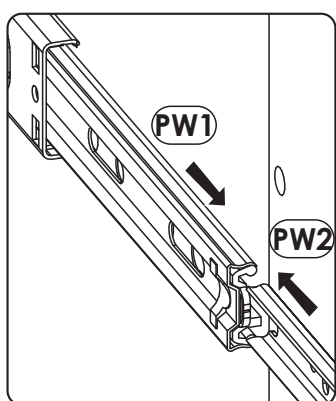
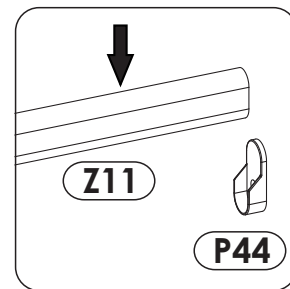
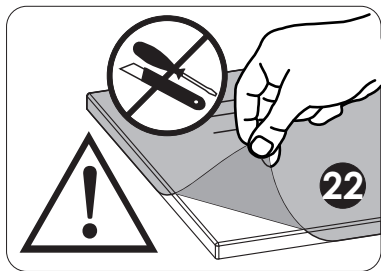

34 ▶

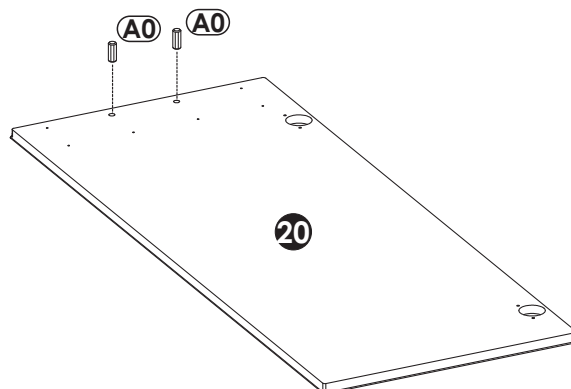
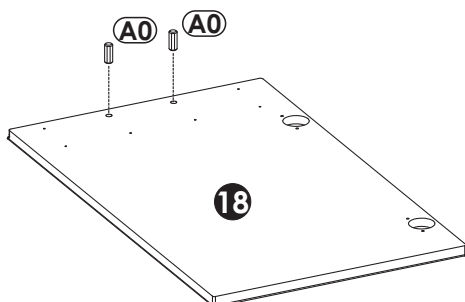
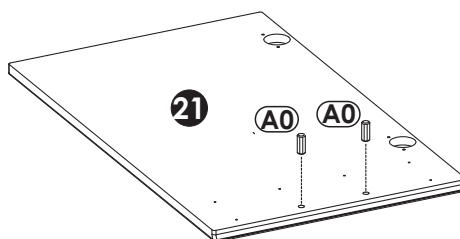
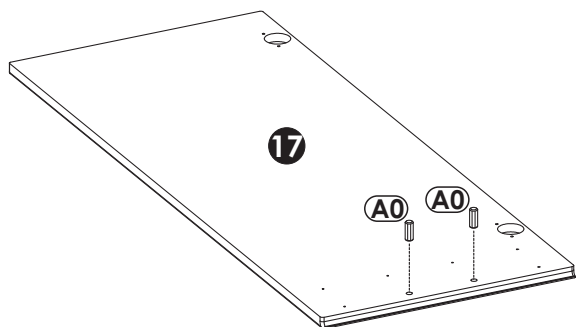
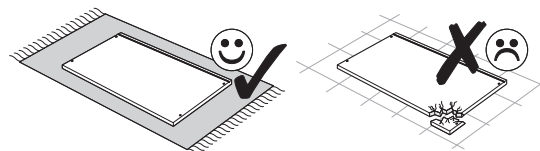

35 ▶

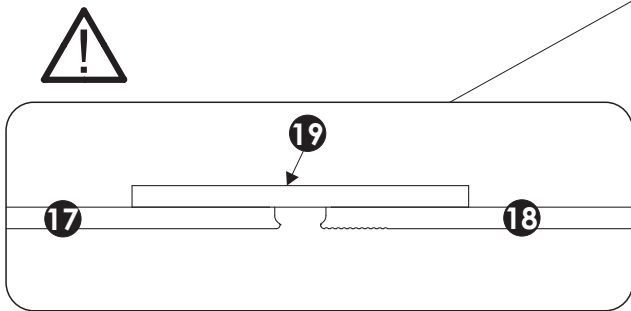
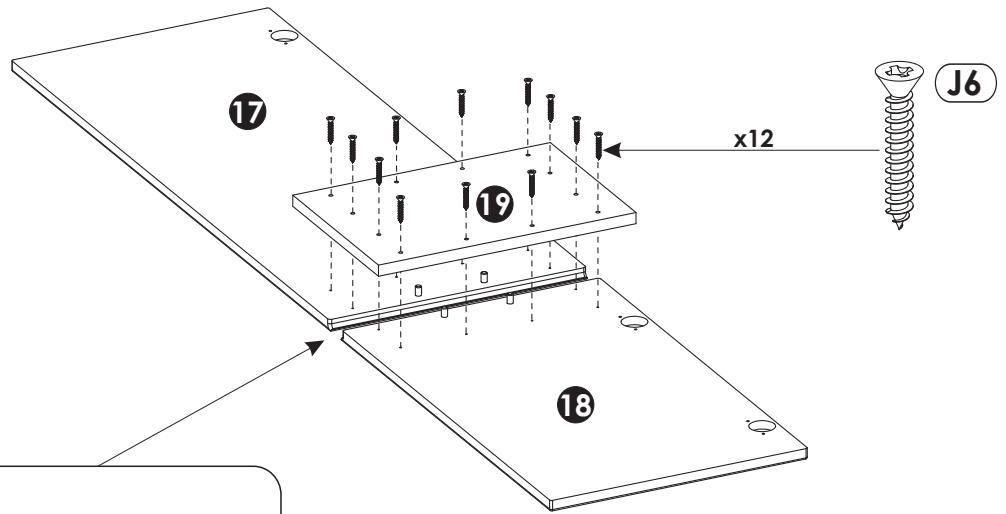
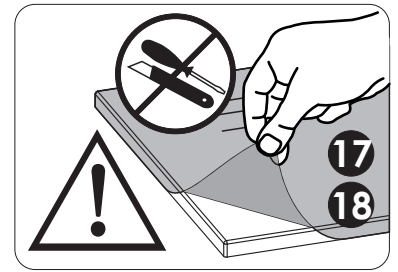
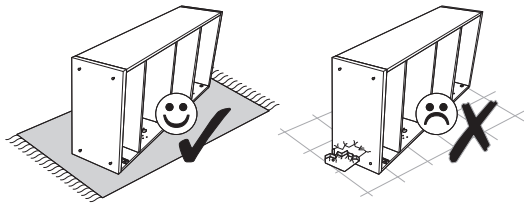

36 ▶

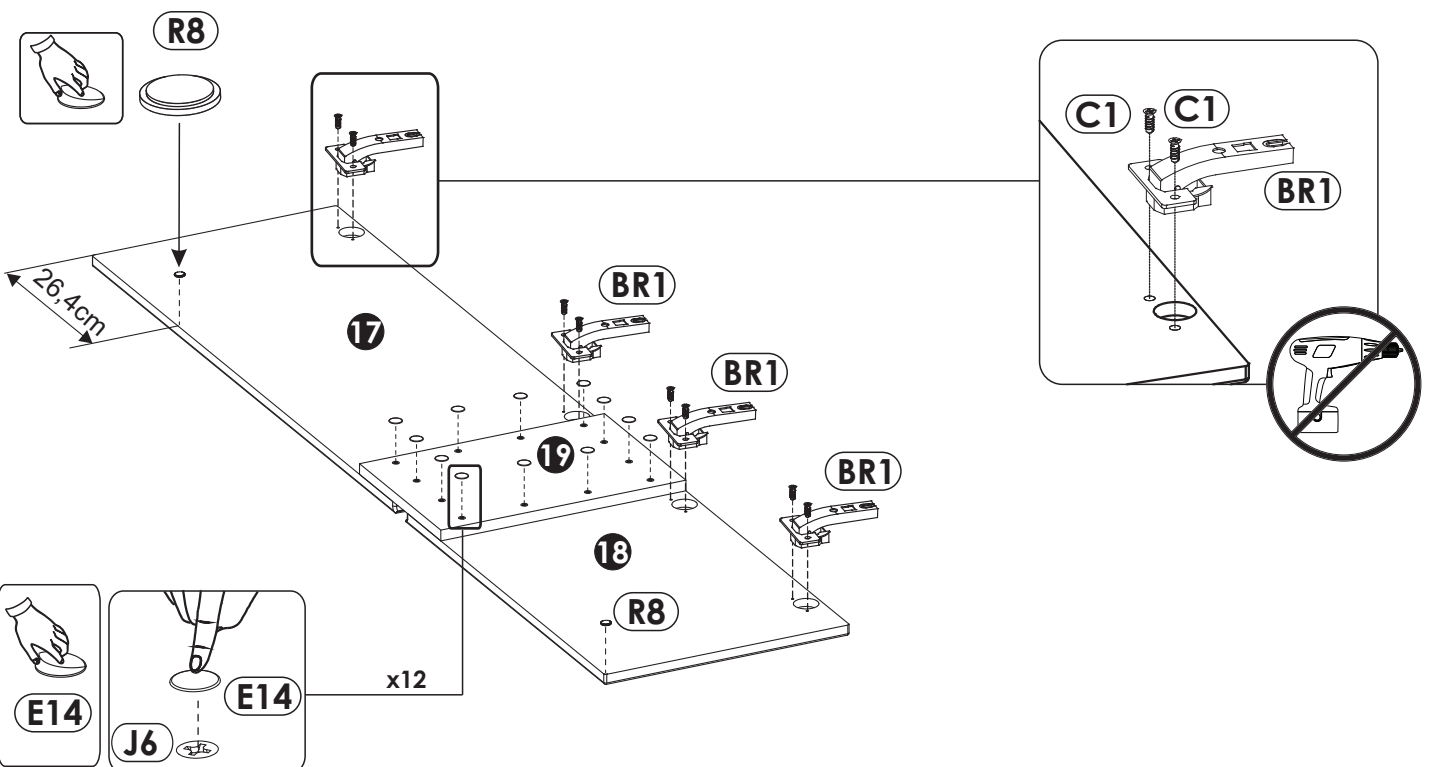
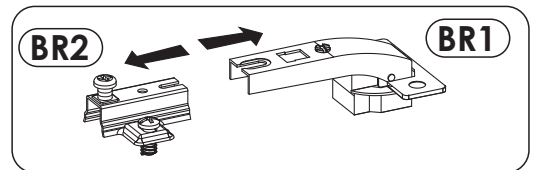
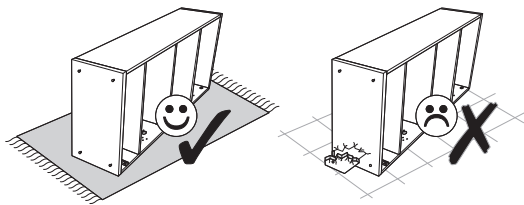

37▶

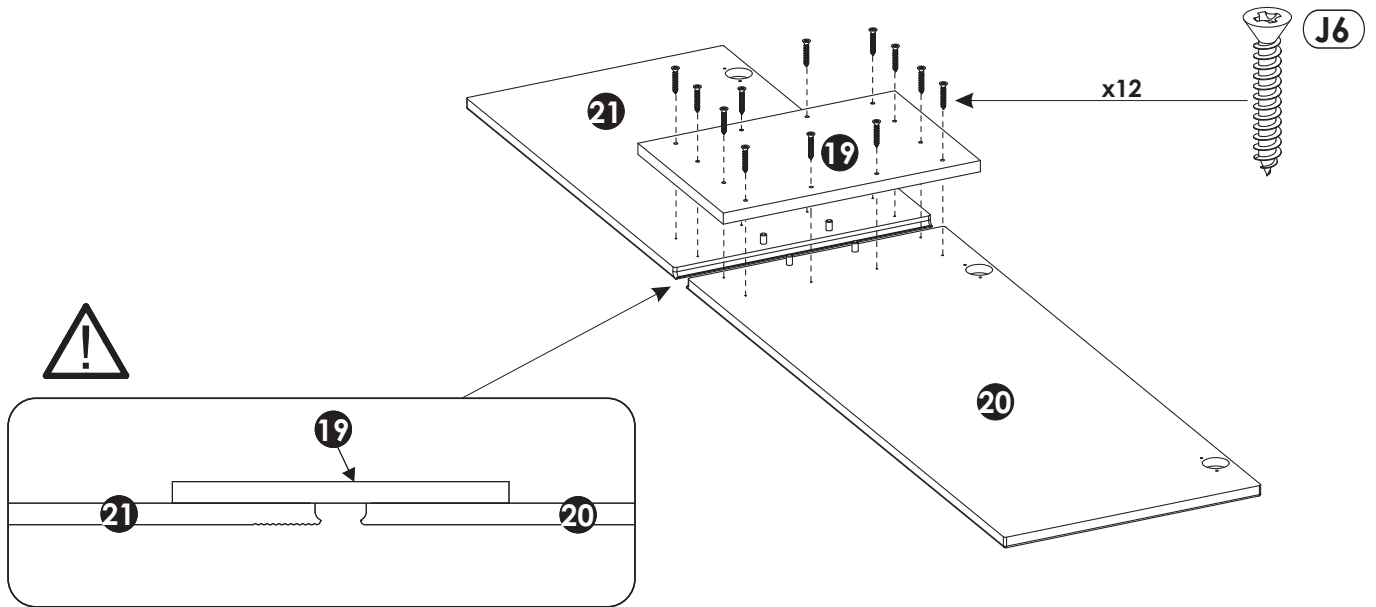
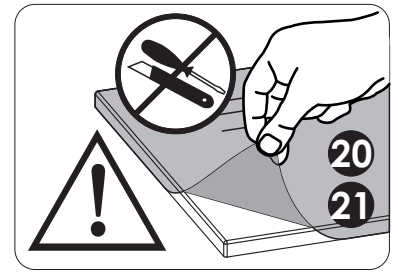
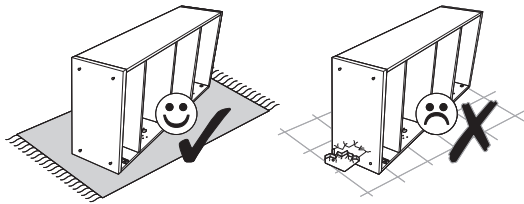

38▶

