

SŁUPEK WYSOKI 1D

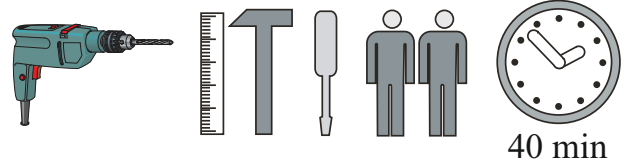

40 min

NO	Dim.			Col.-No	Qty
1	1400	236	16	1	2
2	318	235	16	1	2
3	318	212	16	1	1
4	318	204	16	1	2
5	1394	346	16	1	1
6	1376	328	3	1	1

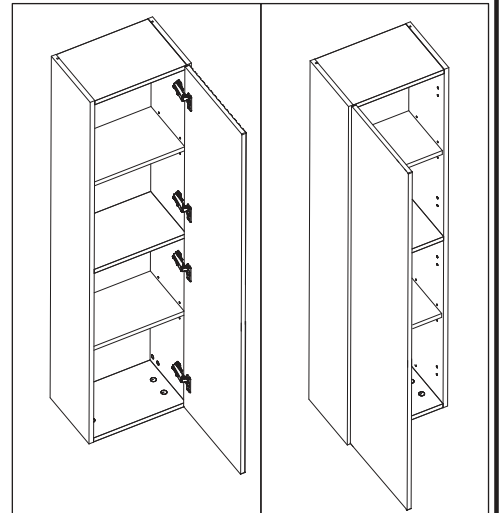
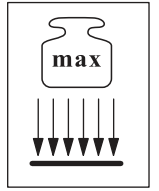
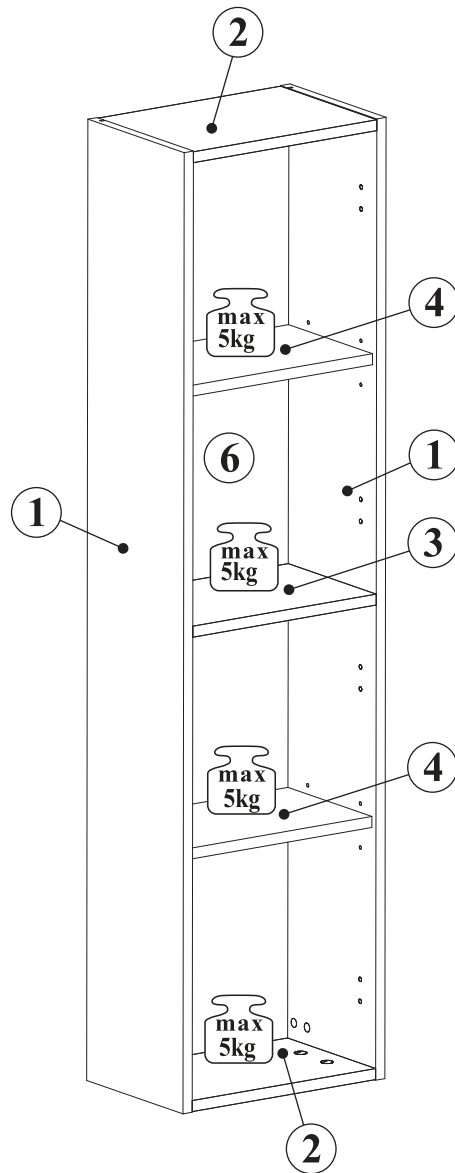
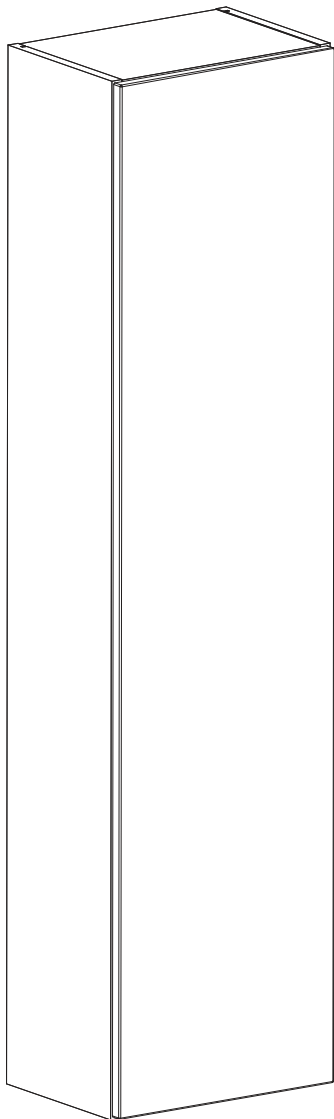
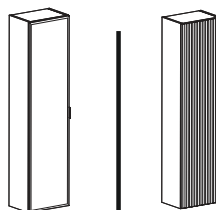

NO	Dim.			Col.-No	Qty
1	1400	236	16	1	2
2	318	235	16	1	2
3	318	212	16	1	1
4	318	204	16	1	2
5	1394	346	17	1	1
6	1376	328	3	1	1



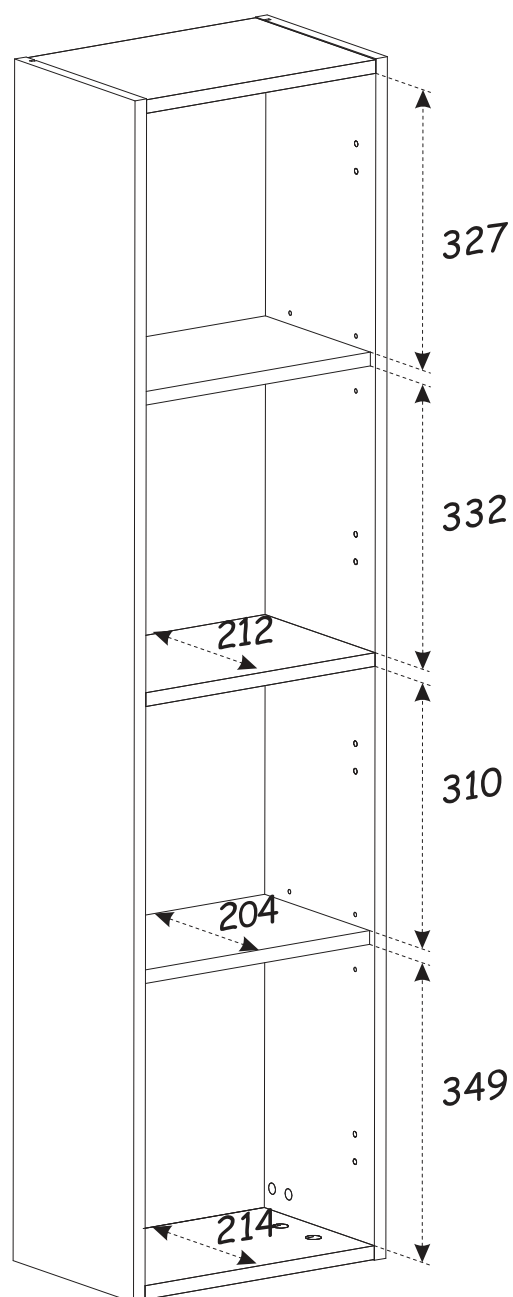
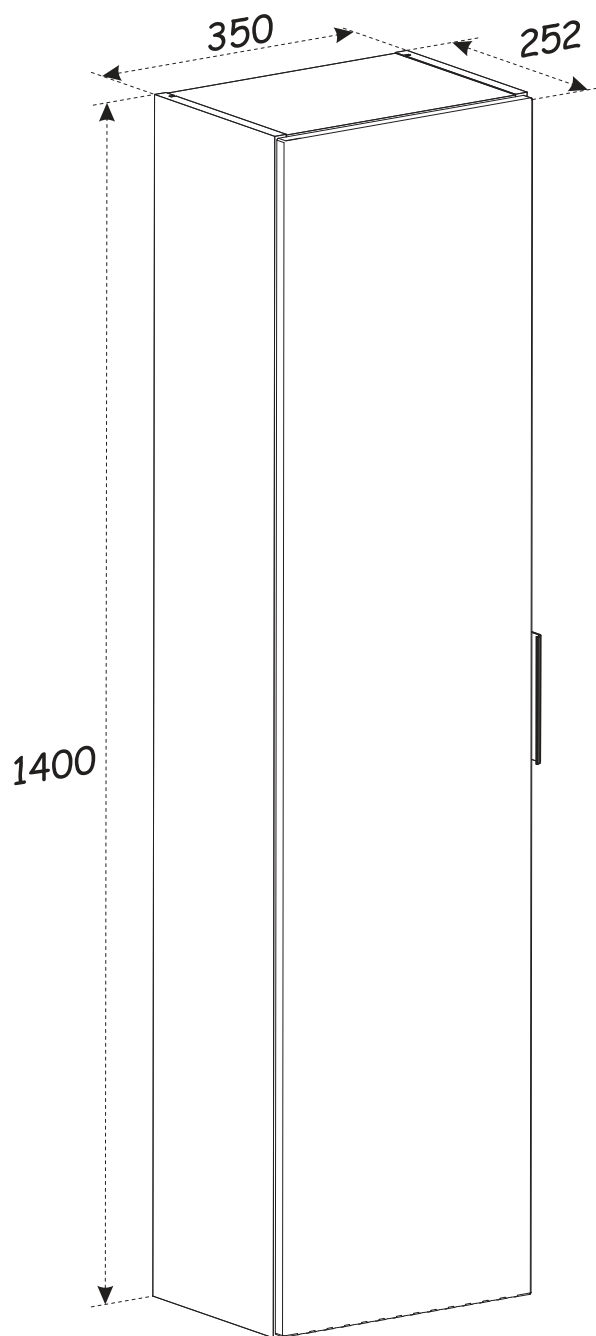



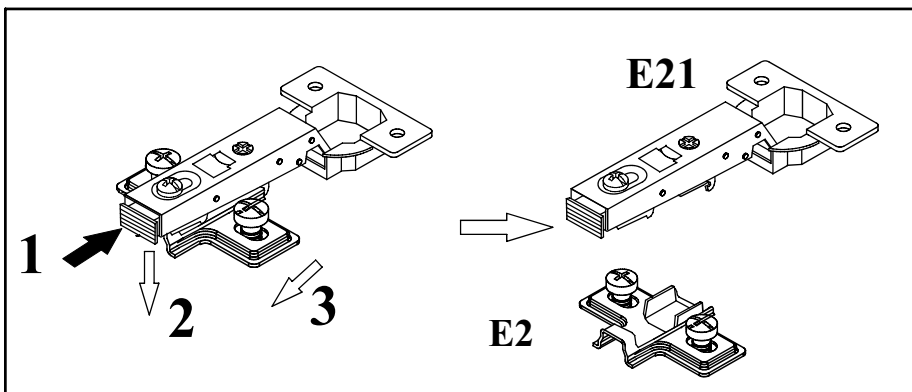
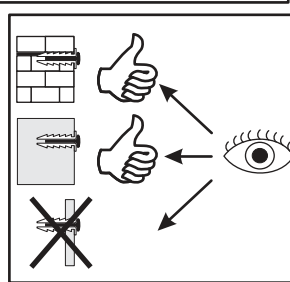
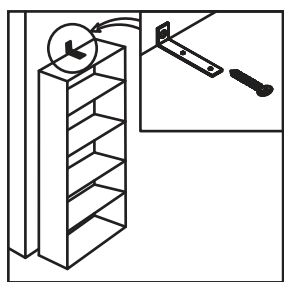
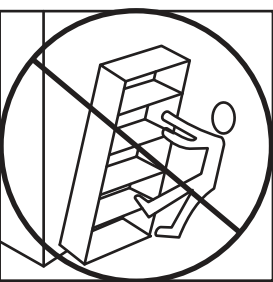
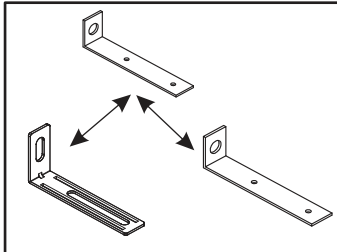
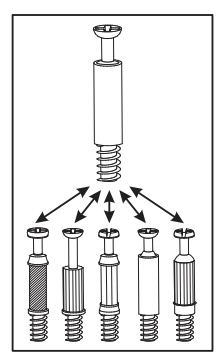
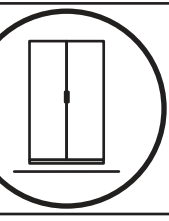
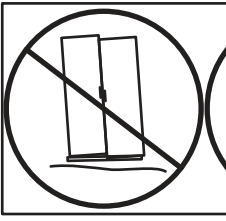
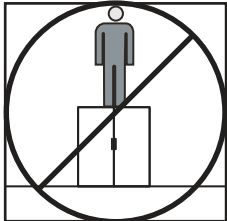
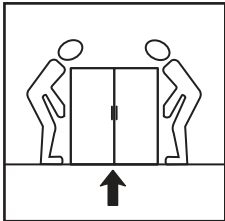
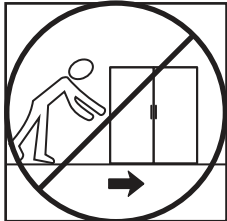
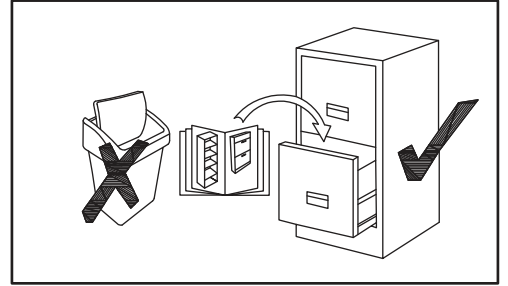
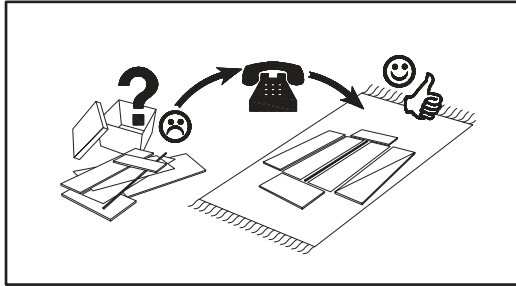
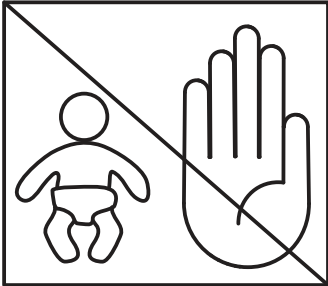
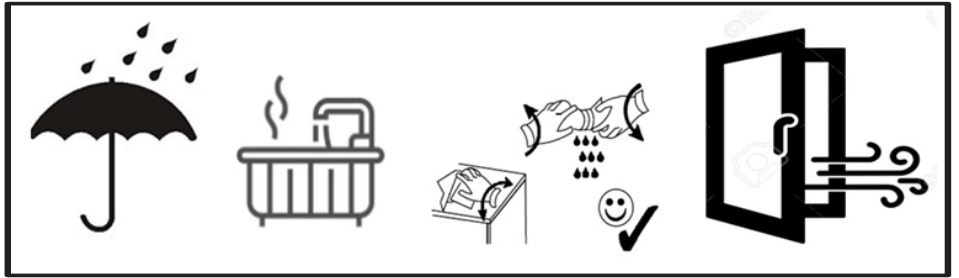
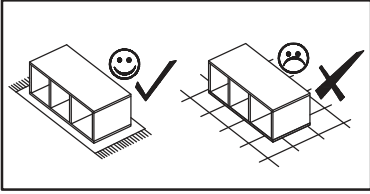
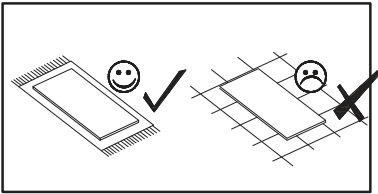



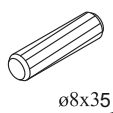
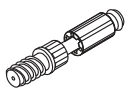

SŁUPEK WYSOKI 1D

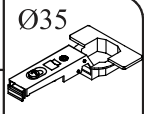
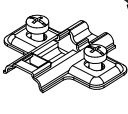

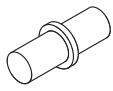
SŁUPEK WYSOKI 1D

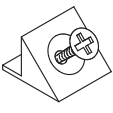
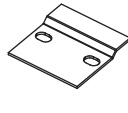

SŁUPEK WYSOKI 1D

A1 x12  ø8x35	B4 x12 	B5 x12  ø15x12	G5 x12 	ZXP x1 	ZXL x1 
E21 x4 Ø35 H=0 	E2 x4 H=0 	D10 x8 USØ3,5x13 	G7 x8 	Z2 x8 Ø5 	Z5 x4 Ø10 
S1 x8 	SZ7 x2 	SZ6 x4 ø4,5x45 ø8x40 	UP13 x3 UPØ3x20 	D6 x4 USØ4x30 	

OPTION 1

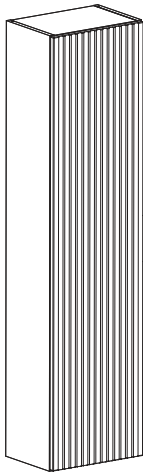

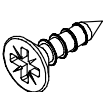
G04 x1 L-148mm. 
D10 x2 USØ3,5x13 

OPTION 2

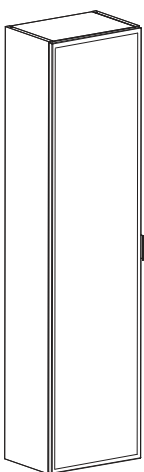

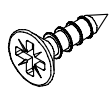
G05 x1 L-32mm. 
D10 x2 USØ3,5x13 

OPTION 3

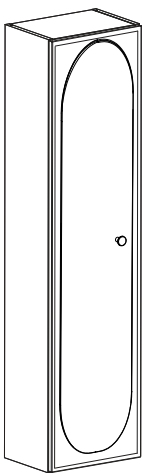

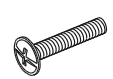

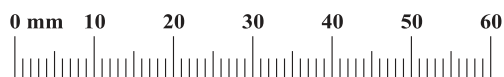
G07 x1 
D12 x1 

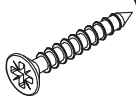

SŁUPEK WYSOKI 1D

1

D6	
x4	USØ3,5x30

Z5	
x4	Ø10

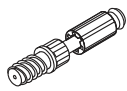
B4	
x12	

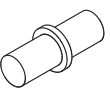
G7	
x8	

ZXP	
x1	

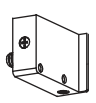
ZXL	
x1	

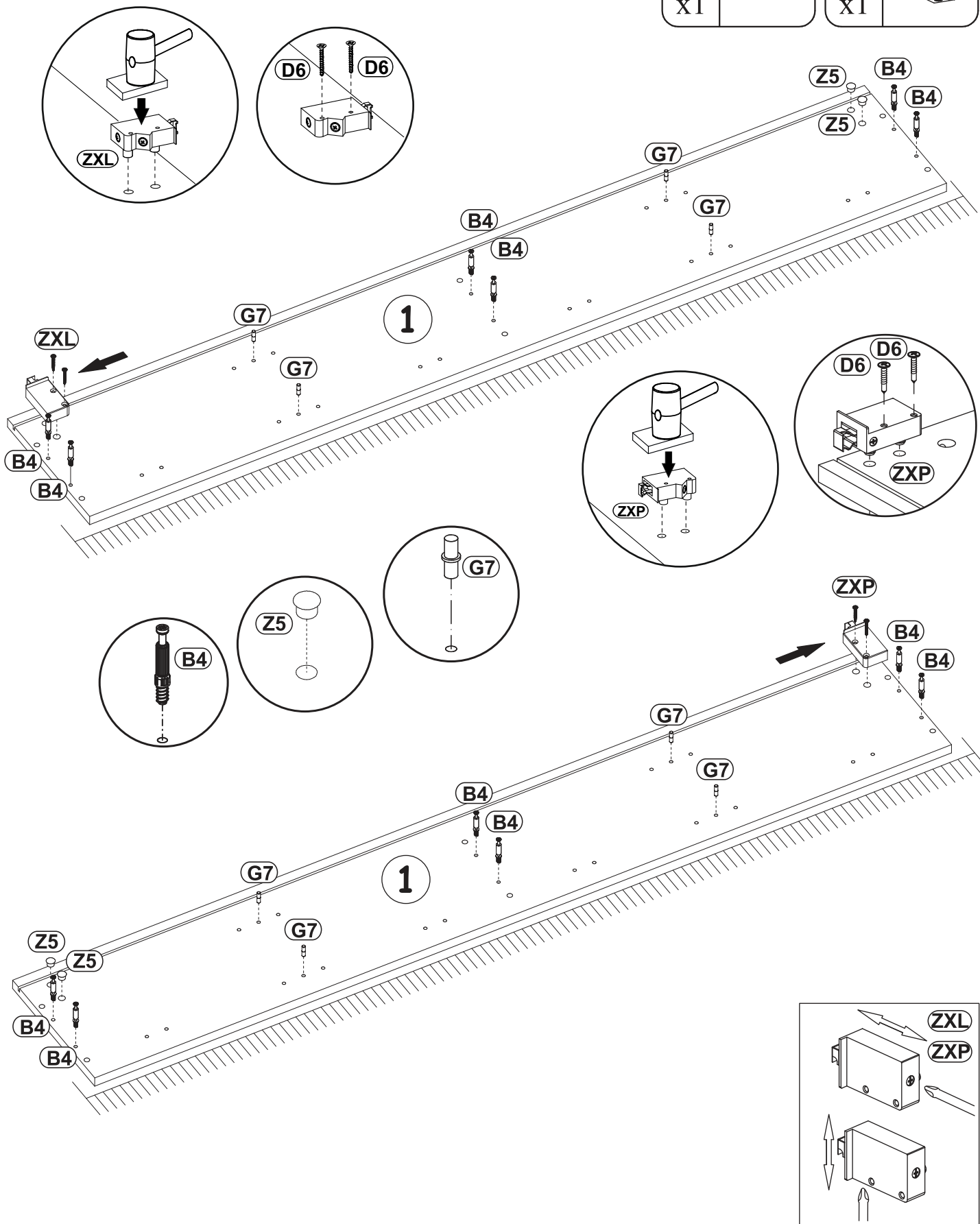



SŁUPEK WYSOKI 1D

2

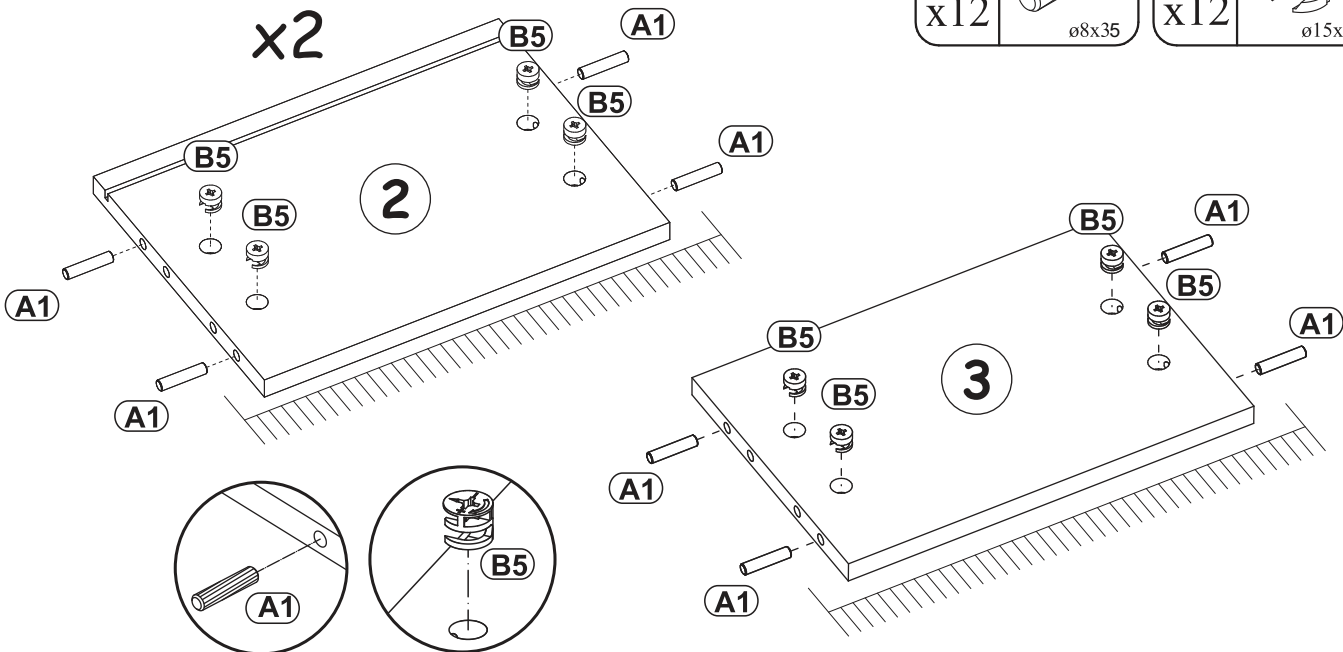
x2





A1		B5	
x12	ø8x35	x12	ø15x12

3

OPTION 1

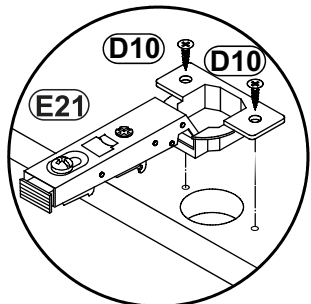
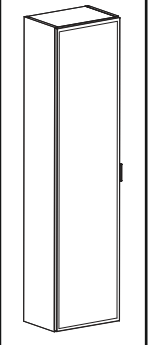
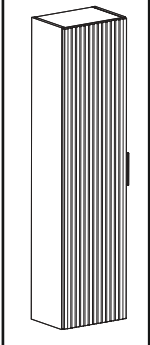
OPTION 2

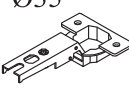

D10		E21	
x8	USØ3,5x13	x4	Ø35 H=0

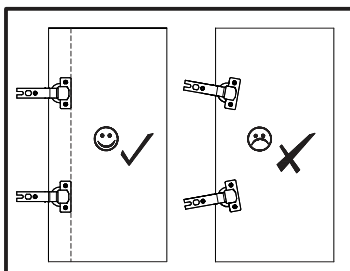
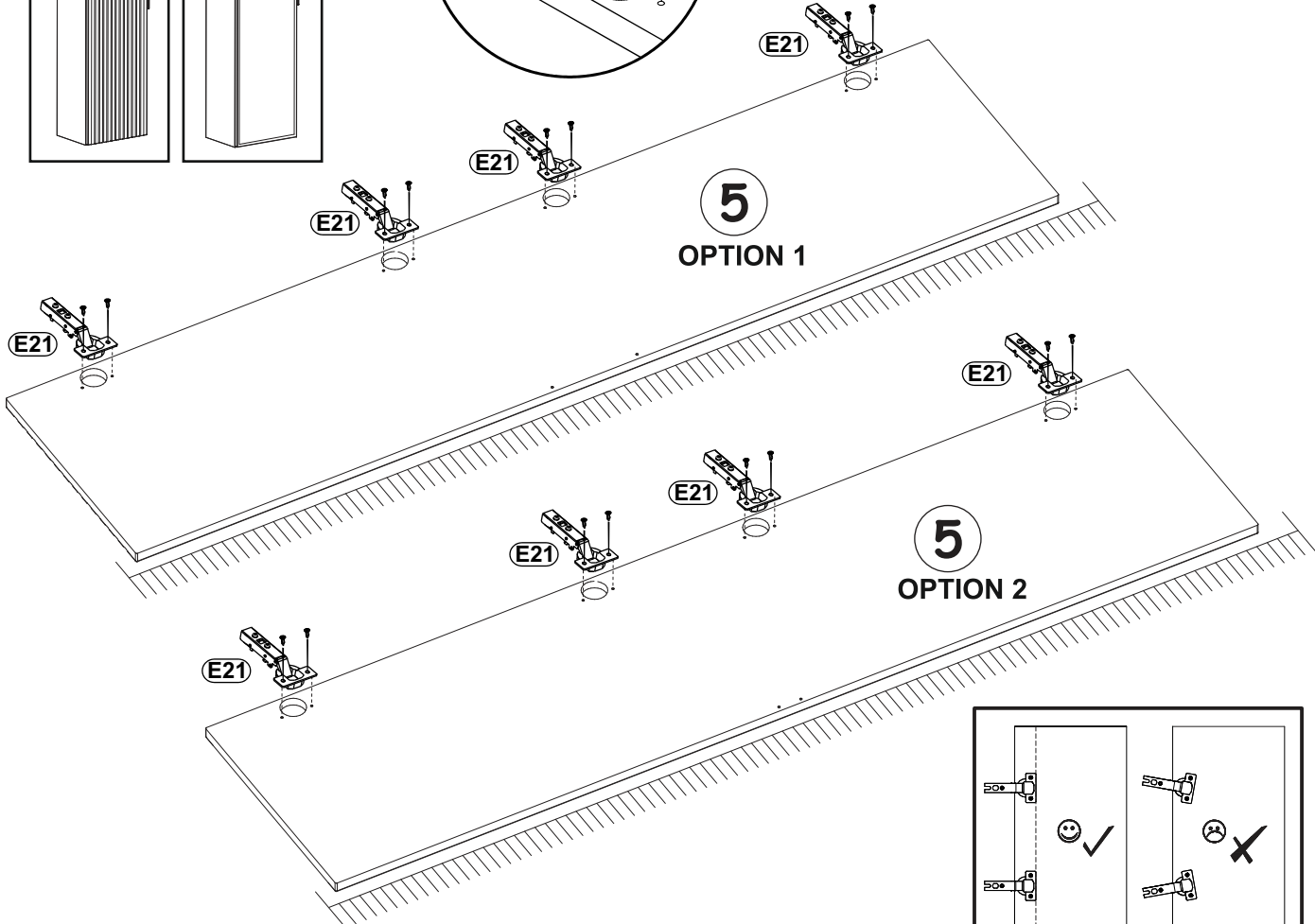

SŁUPEK WYSOKI 1D

4

G5	
x6	

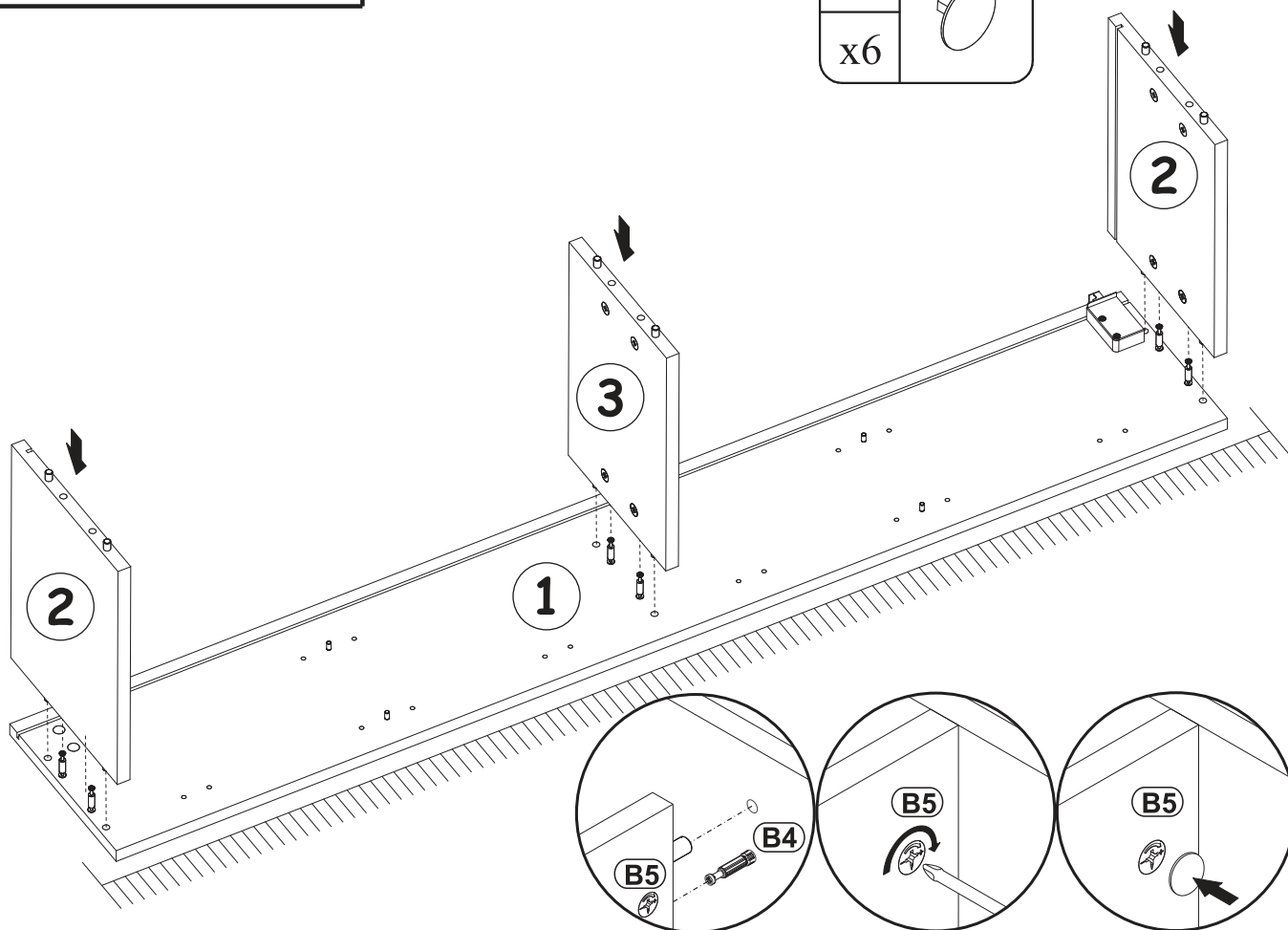

5

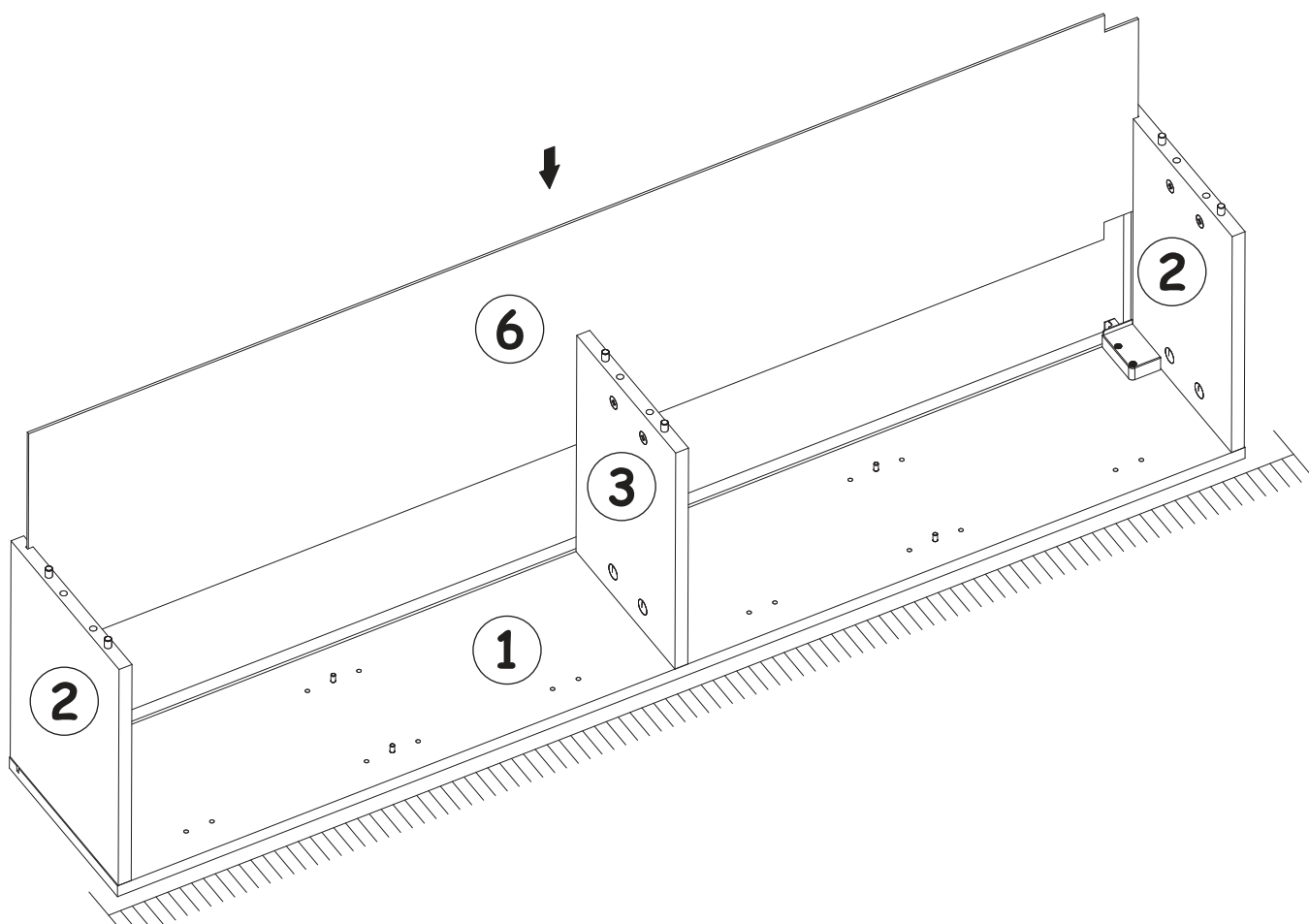

SŁUPEK WYSOKI 1D

6

G5	
x6	

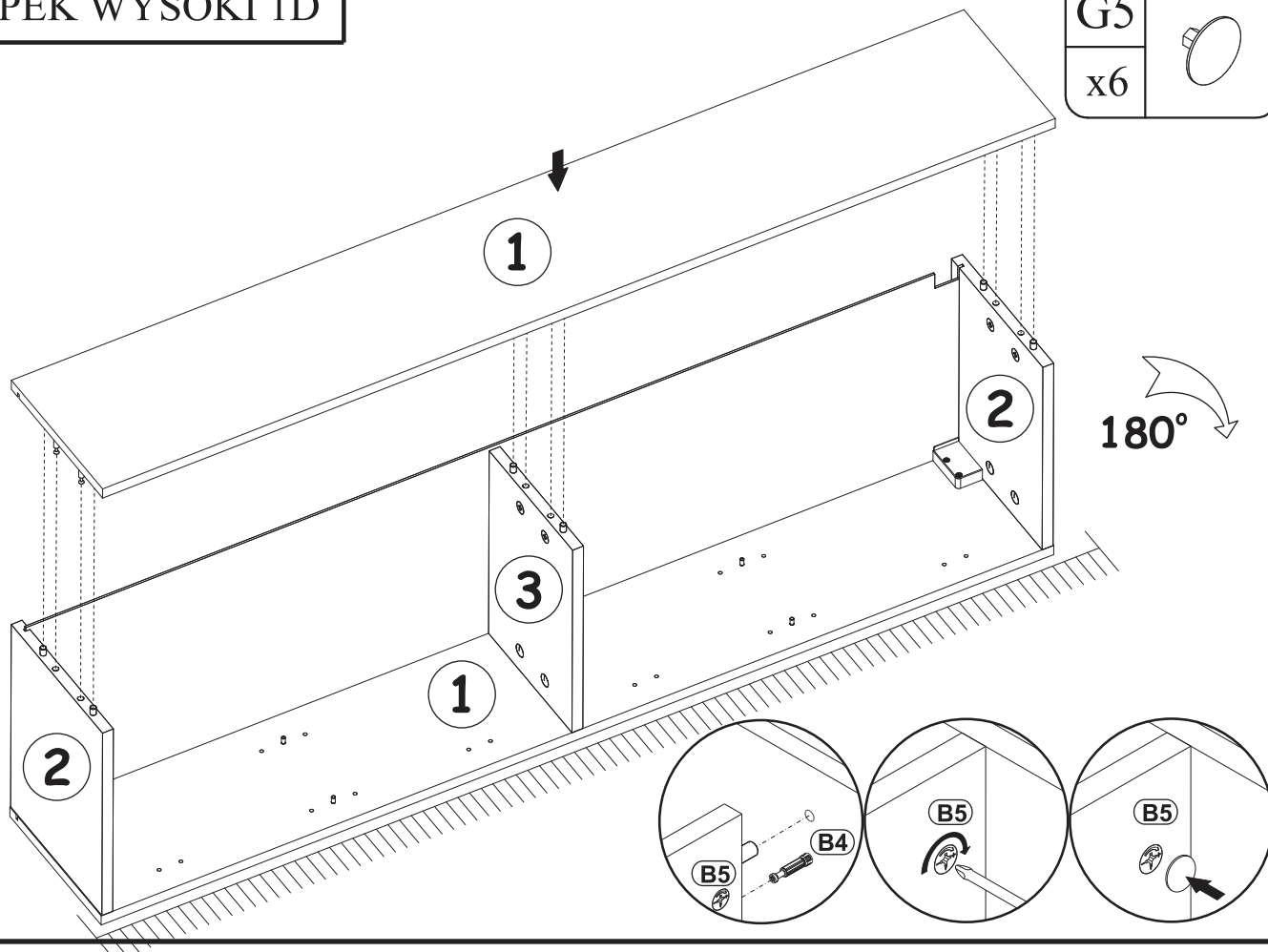

7

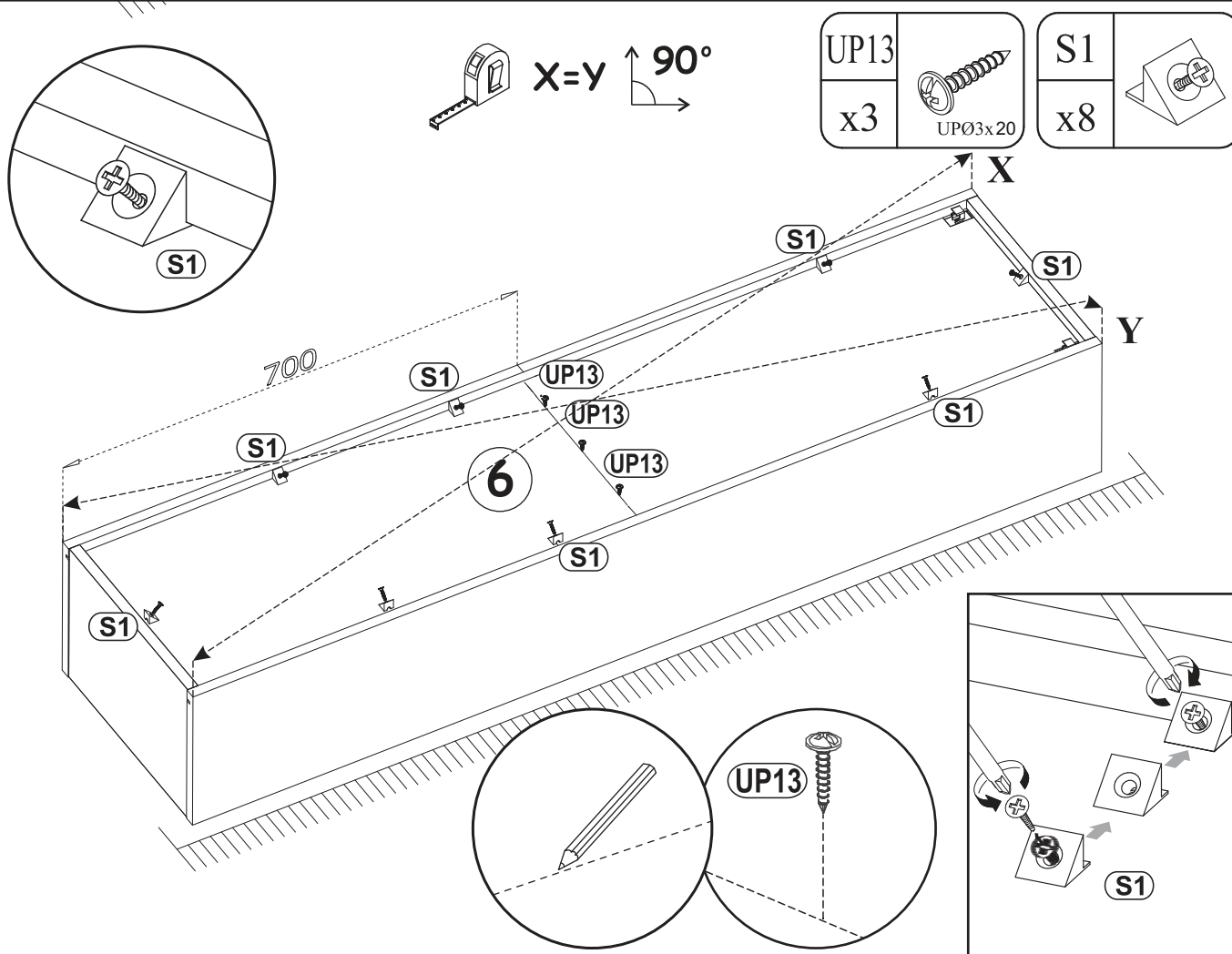

SŁUPEK WYSOKI 1D

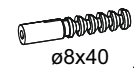
SZ6	
x4	

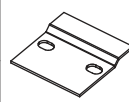
SZ7	
x2	

8

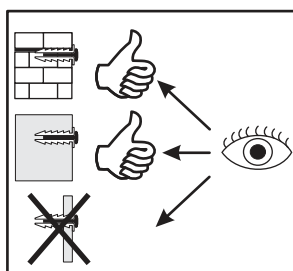
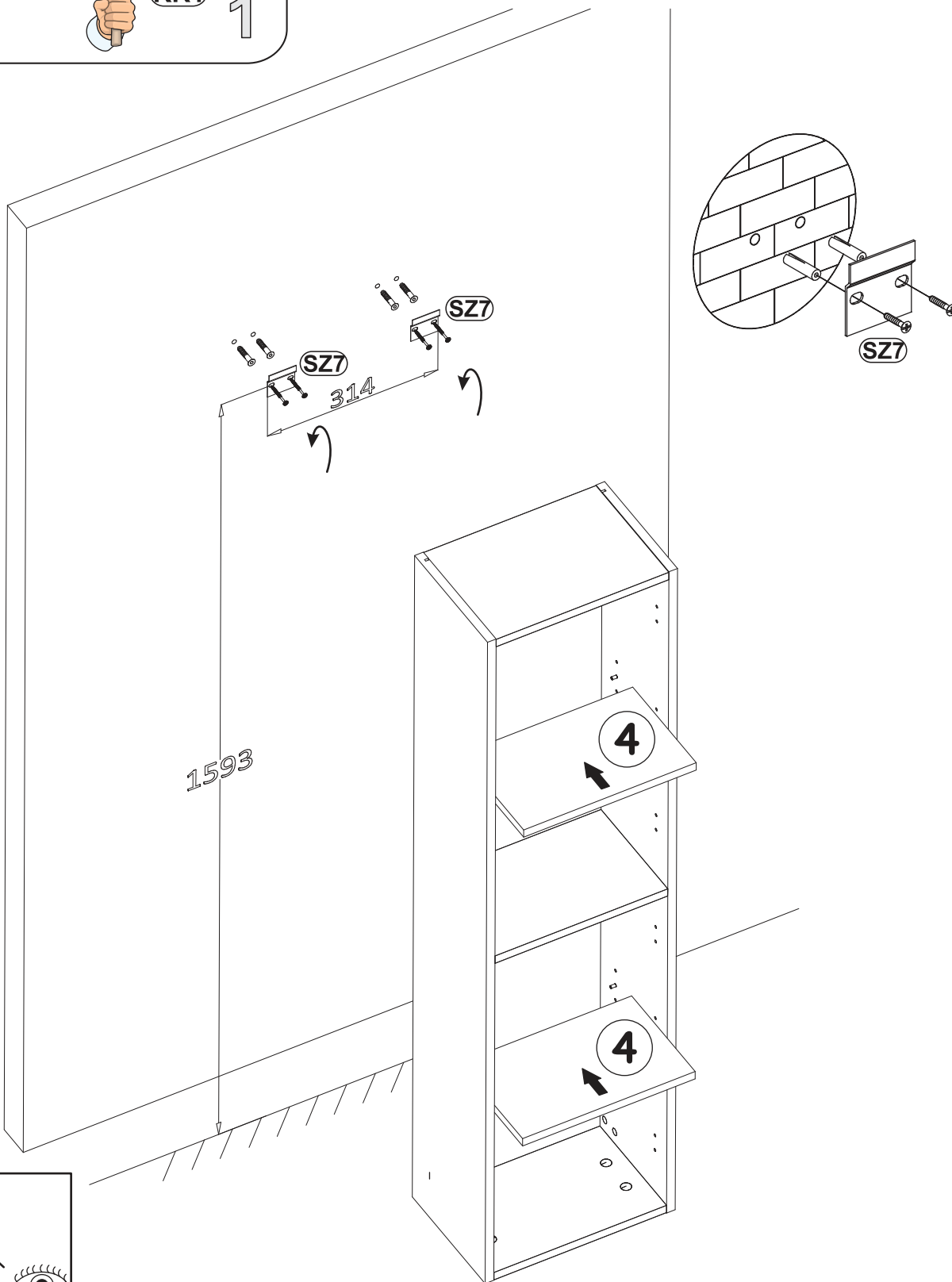
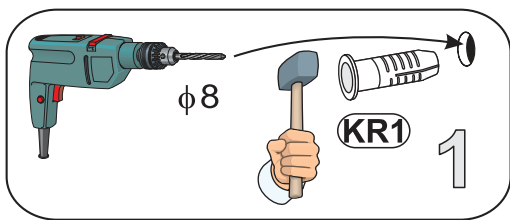

9-11

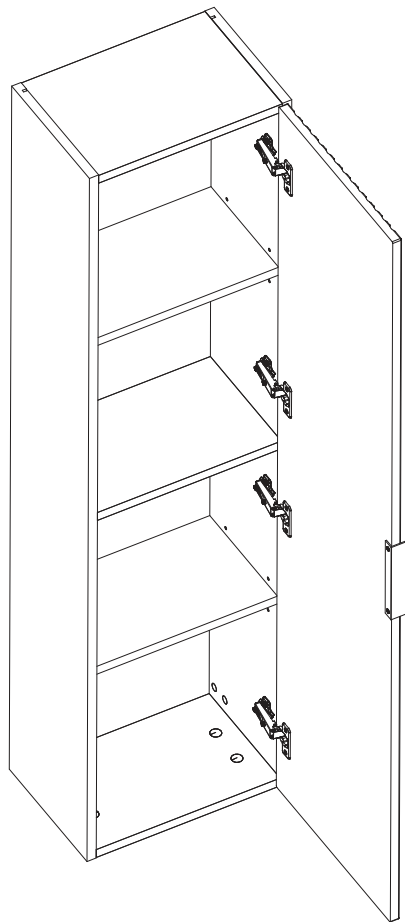

12-14

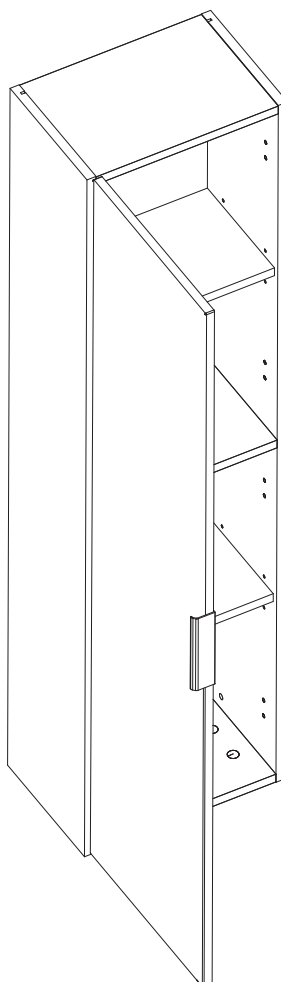

SŁUPEK WYSOKI 1D

9

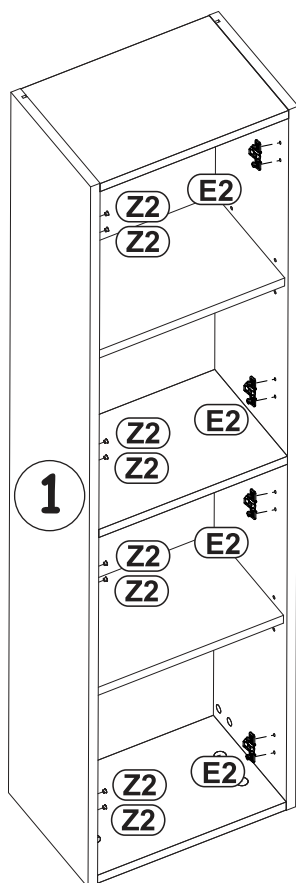
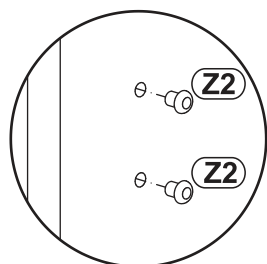
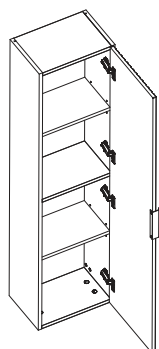

Z2		E2	
x8	Ø5	x4	H=0

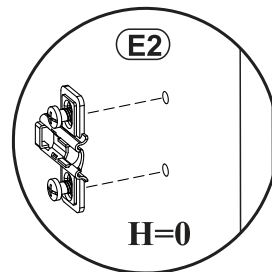

10

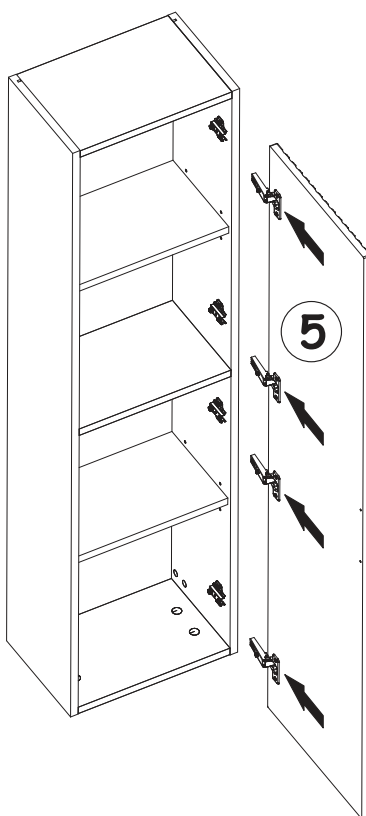
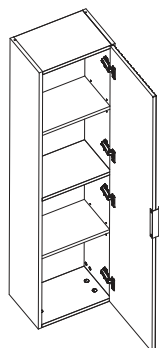

SŁUPEK WYSOKI 1D

11

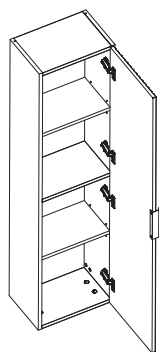

OPTION 1

G04	
x1	L-148mm.
D10	
x2	USø3,5x13

OPTION 2

G05	
x1	L-32mm.
D10	
x2	USø3,5x13

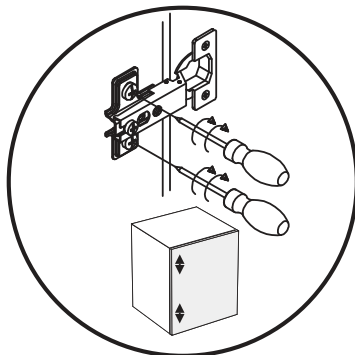
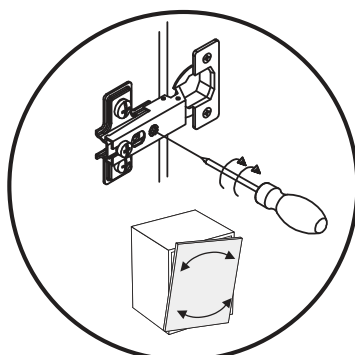
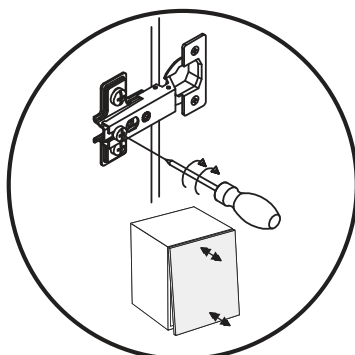
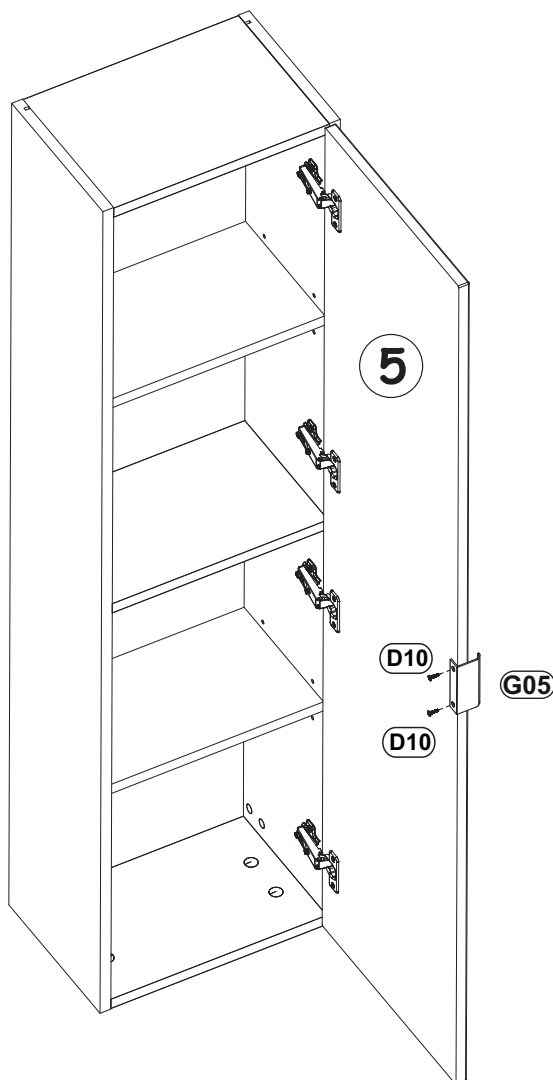
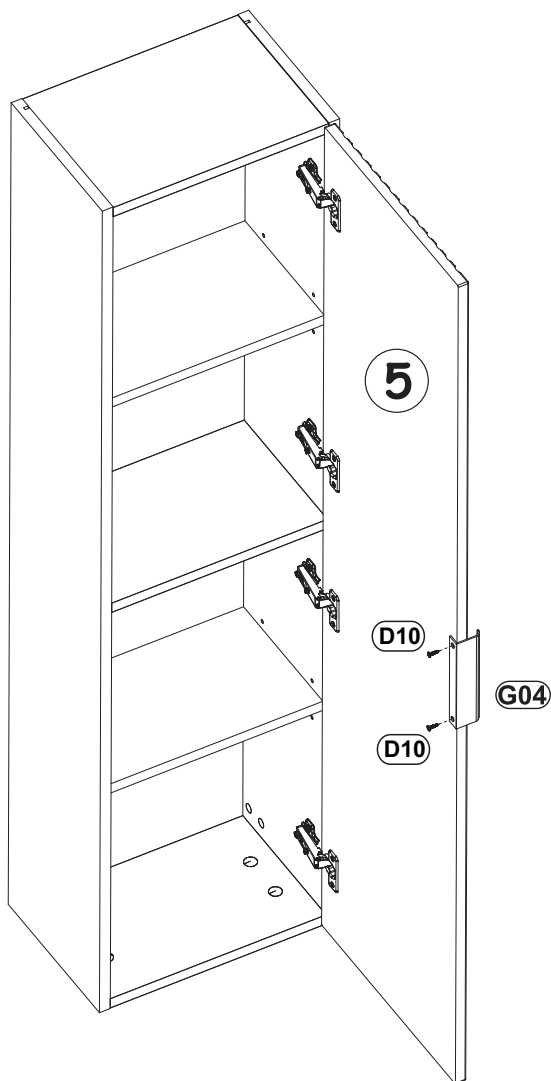

SŁUPEK WYSOKI 1D

11

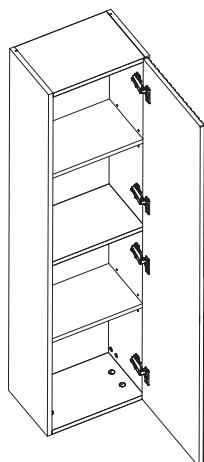

OPTION 3

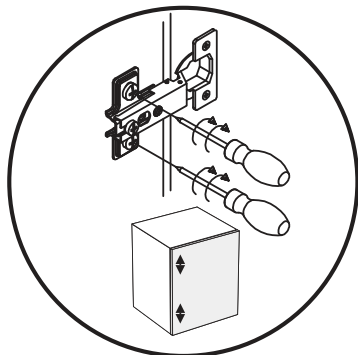
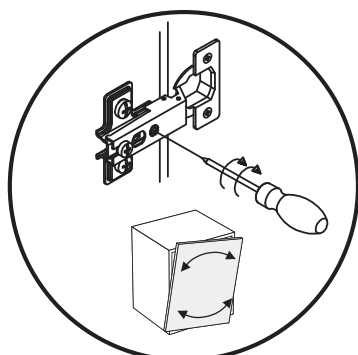
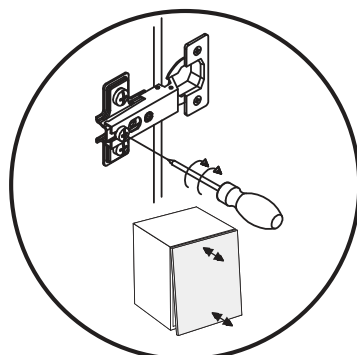
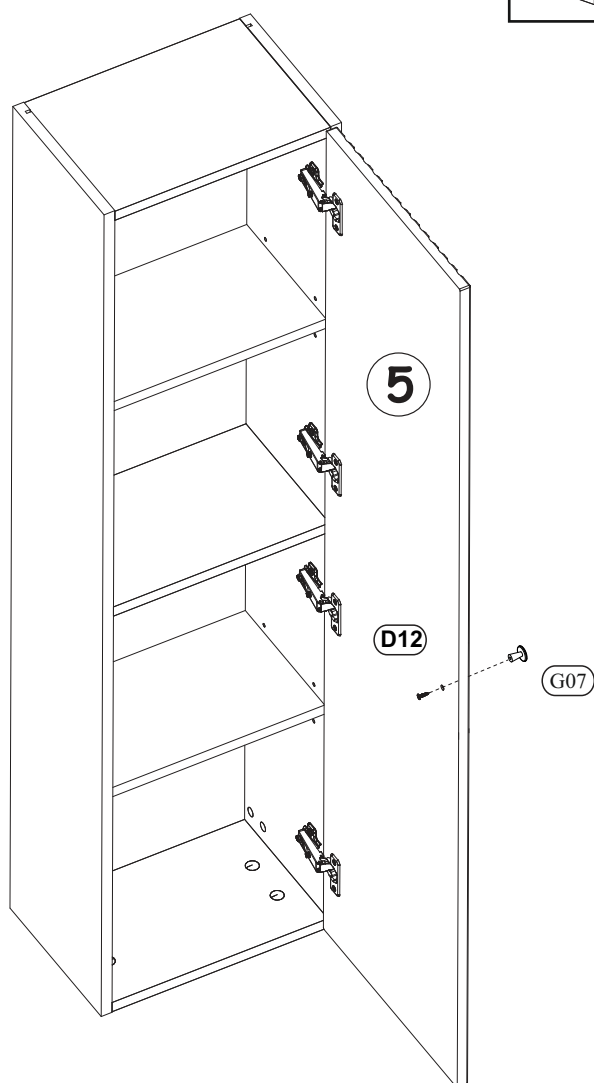
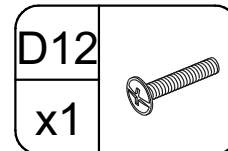
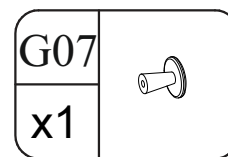
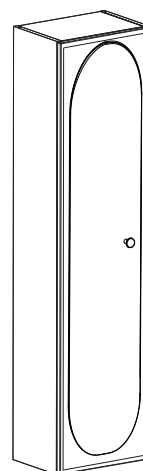

SŁUPEK WYSOKI 1D

12

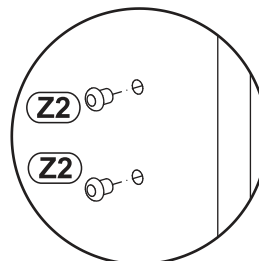
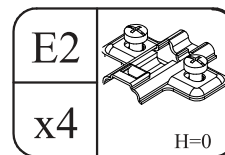
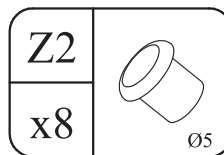
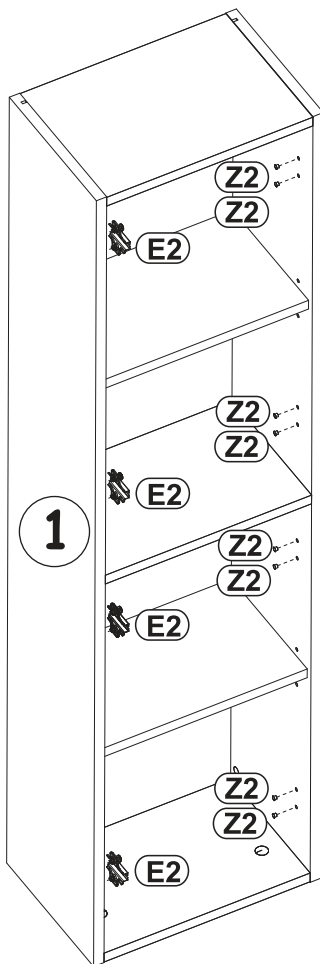
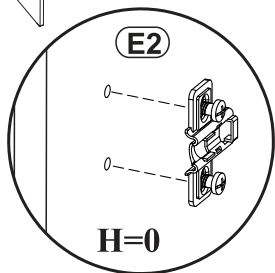
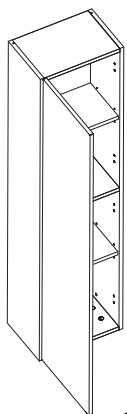

13

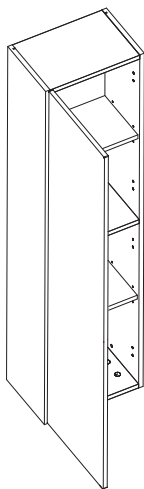

SŁUPEK WYSOKI 1D

14

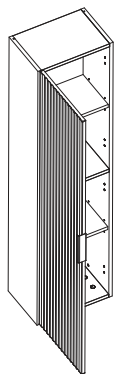

OPTION 1

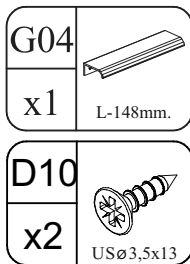
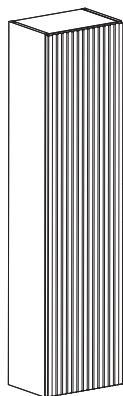

OPTION 2

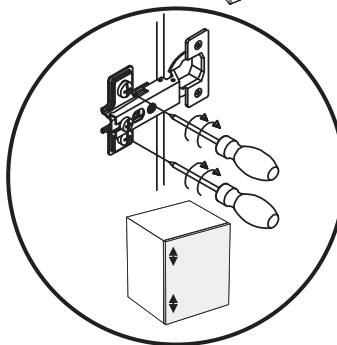
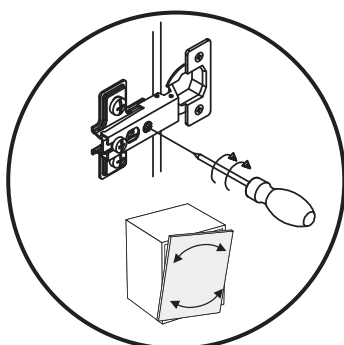
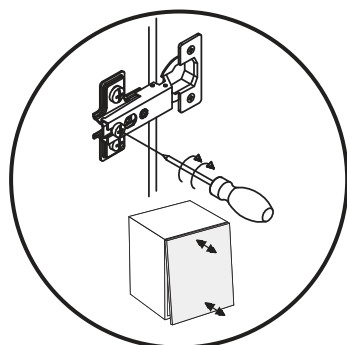
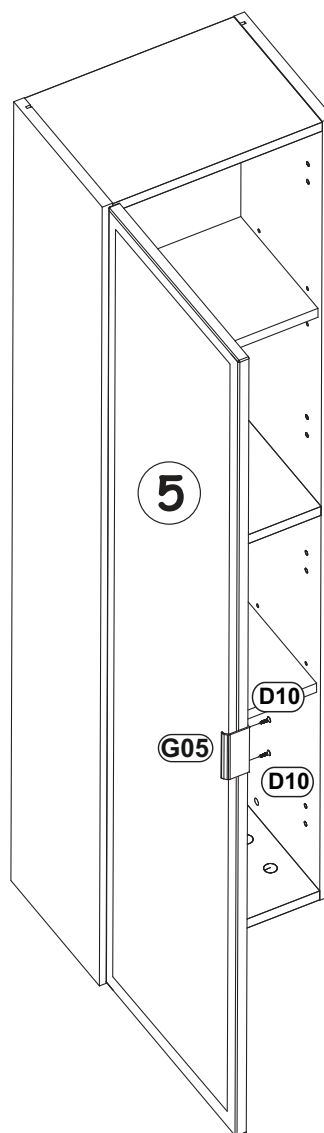
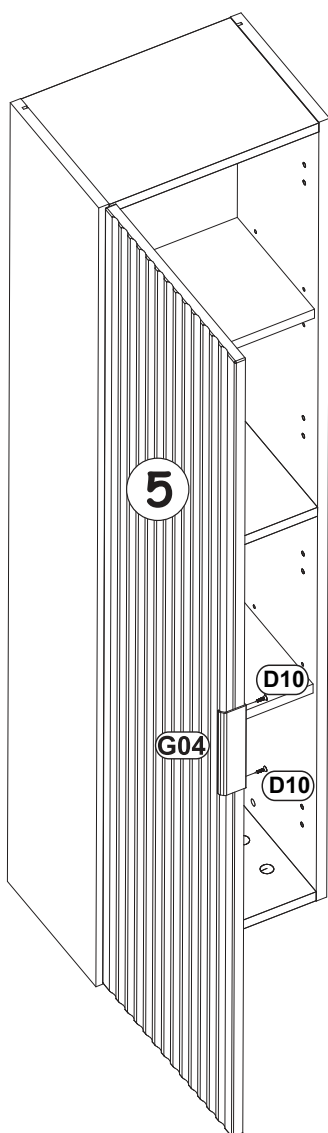
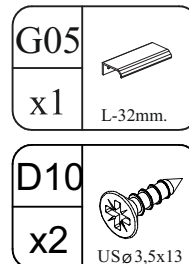
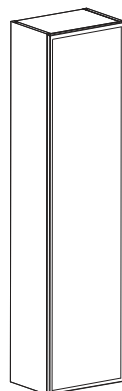

SŁUPEK WYSOKI 1D

11

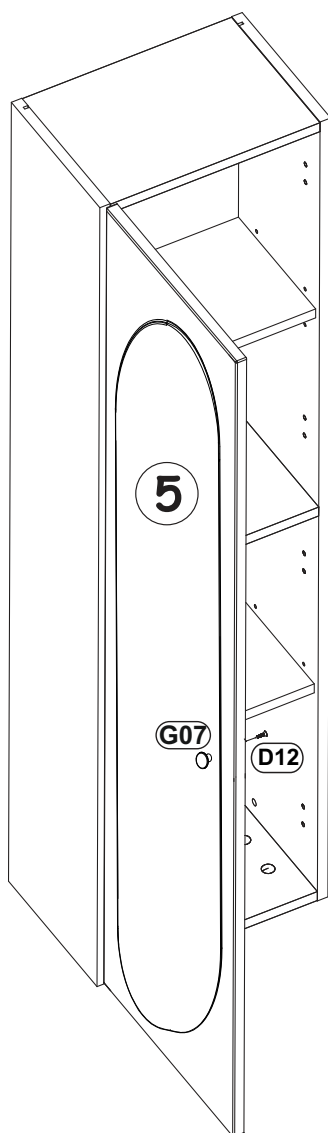
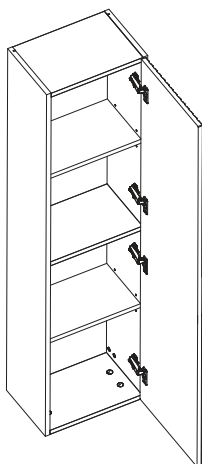

OPTION 3

