

360 min

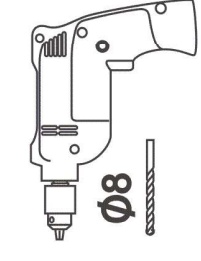

A

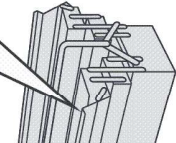
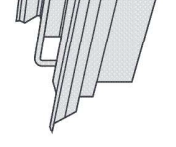
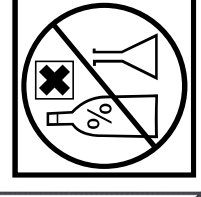
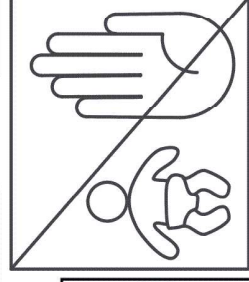
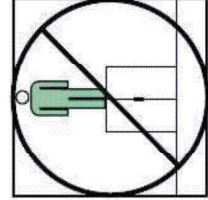
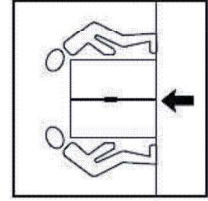
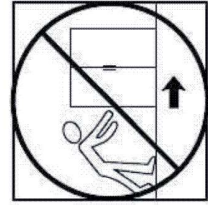
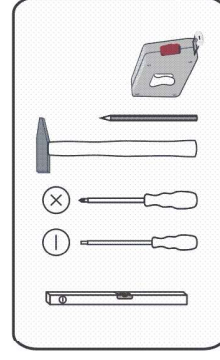
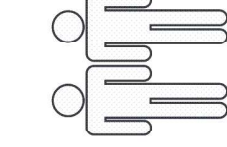
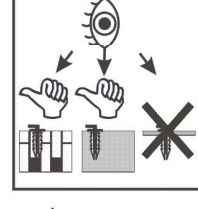
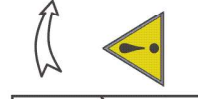
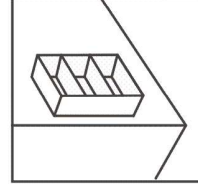
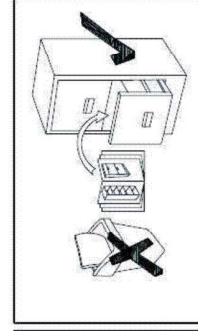
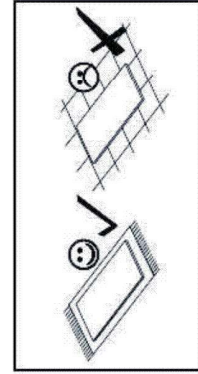
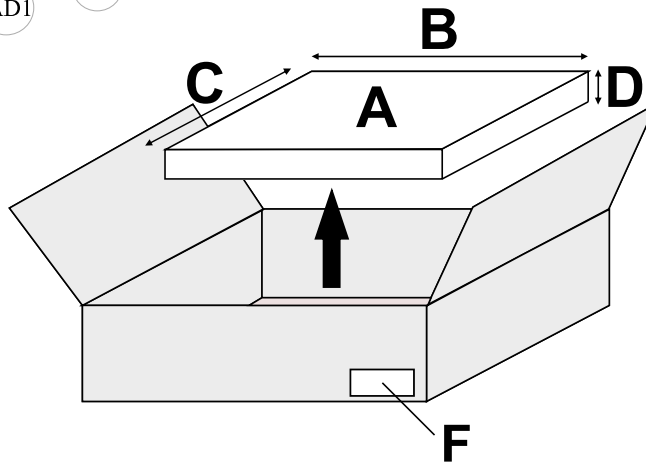
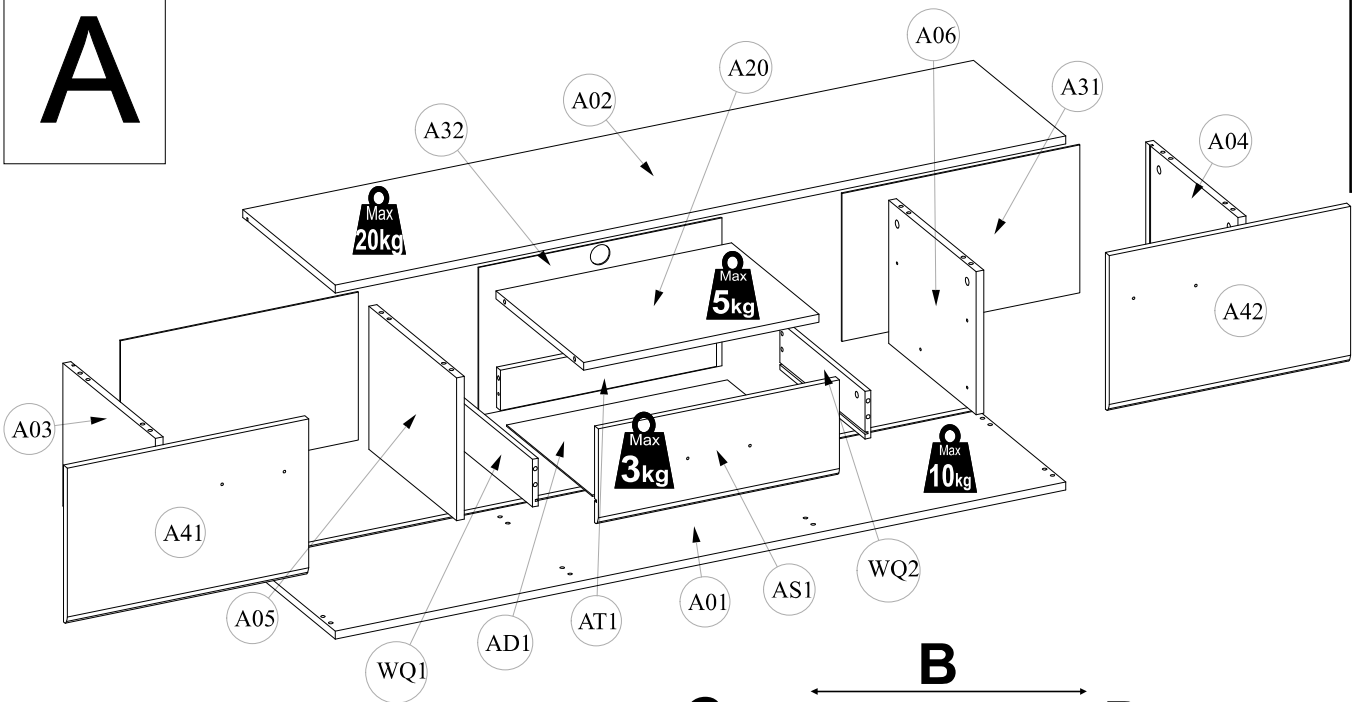

A	B_(mm)	C_(mm)	D_(mm)	E	F
A01	1502	380	16	1	5/5
A02	1502	380	16	1	5/5
A03	288	380	16	1	5/5
A04	288	380	16	1	5/5
A05	288	360	16	1	5/5
A06	288	360	16	1	5/5
A20	484	360	16	1	5/5
A31	298	489	3	2	5/5
A32	298	500	3	1	5/5
A41	496	316	16	1	5/5
A42	496	316	16	1	5/5
AD1	454	353	3	1	5/5
AS1	496	195	16	1	5/5
AT1	444	81	16	1	5/5
WQ1	350	96	12	1	5/5
WQ2	350	96	12	1	5/5

1

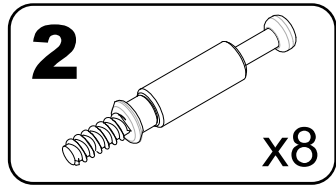
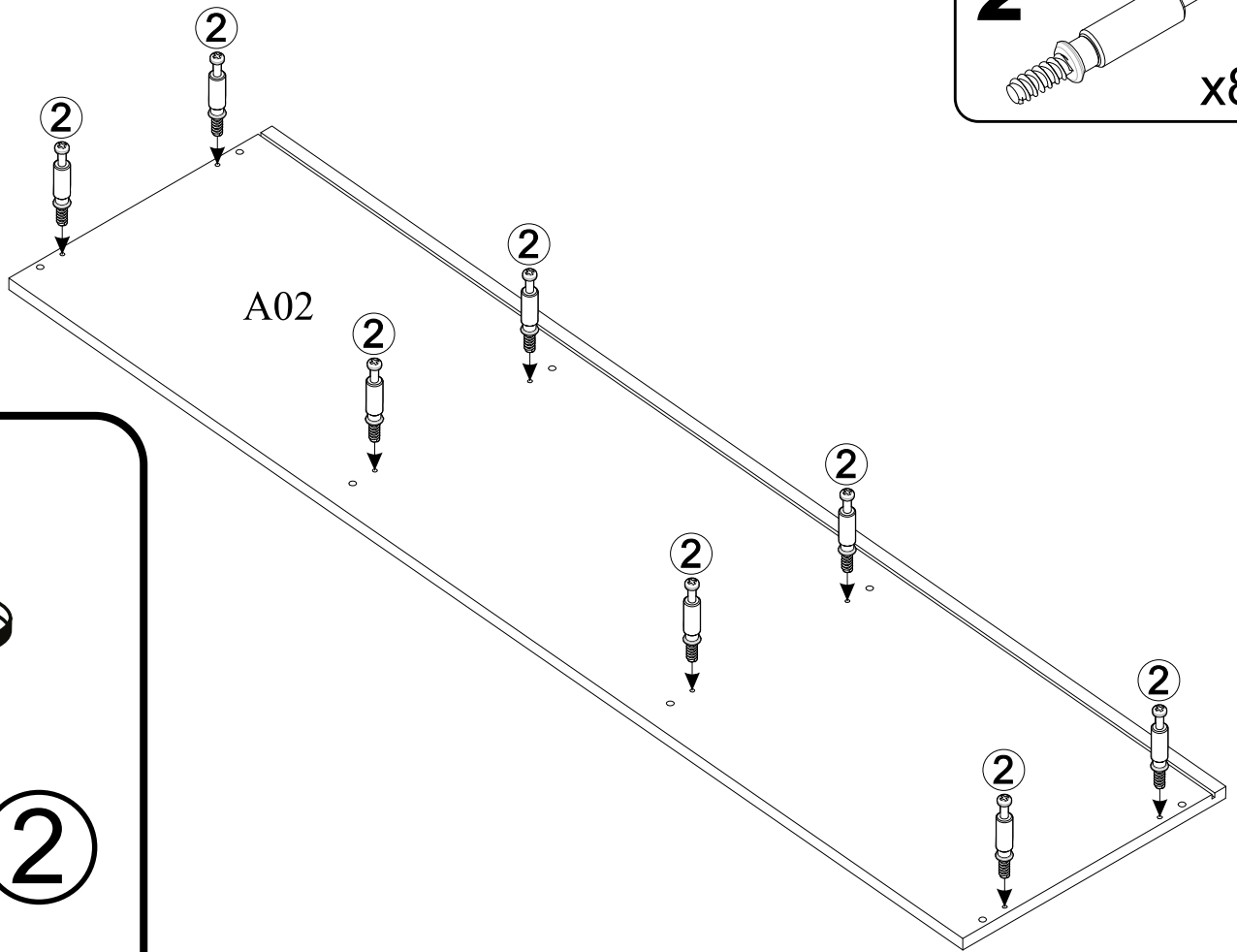
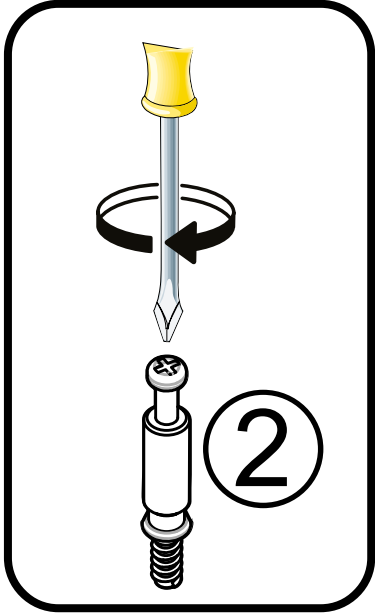

2

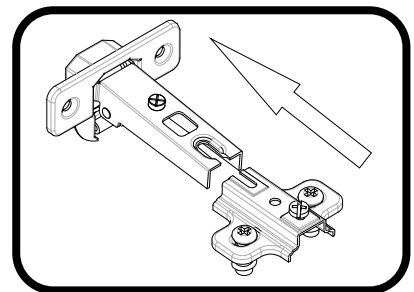
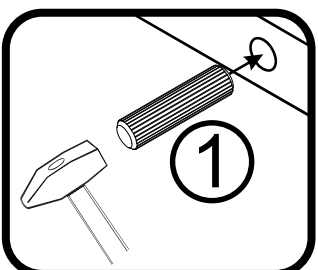
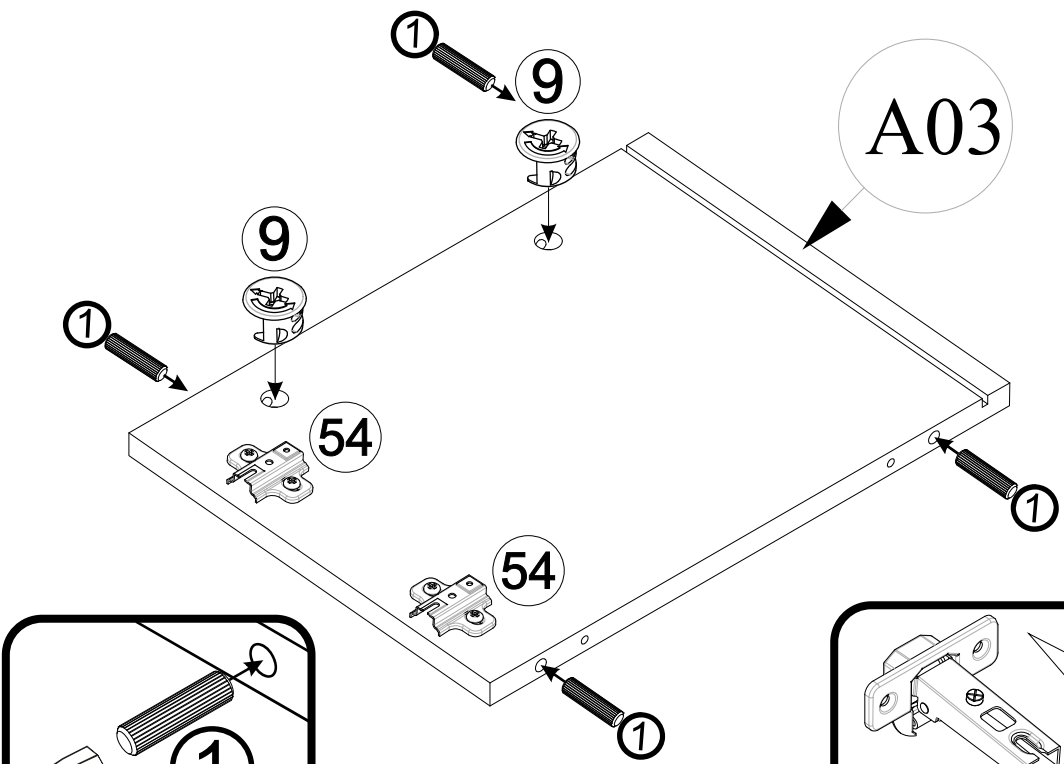
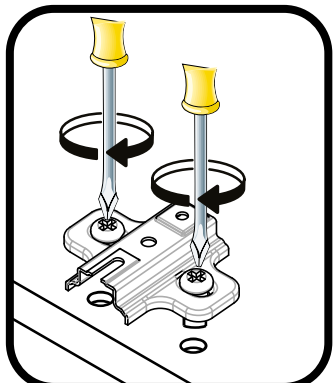
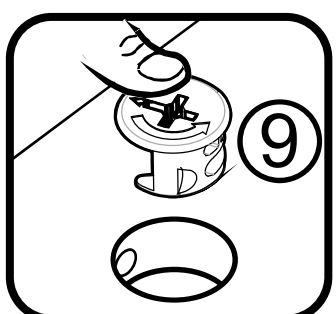
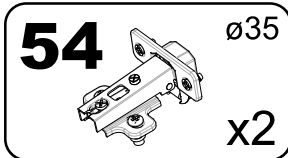
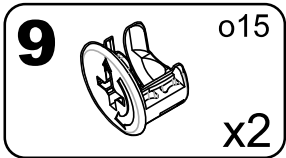
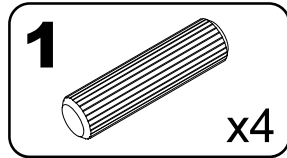

3

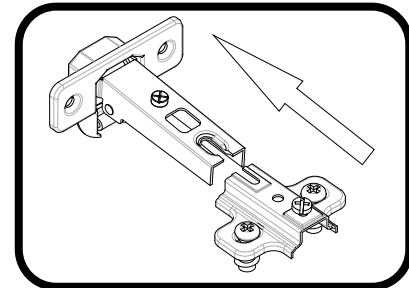
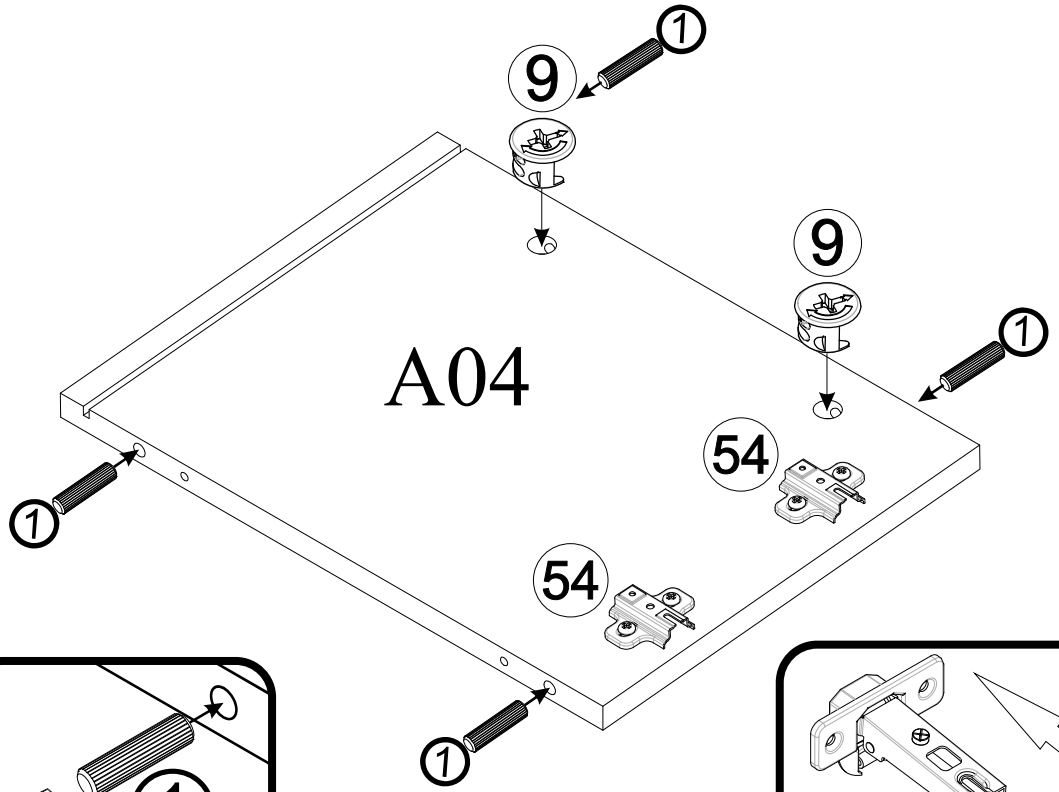
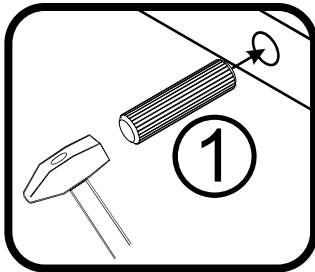
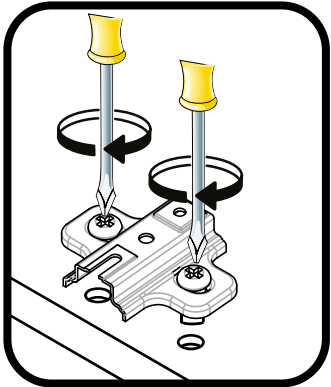
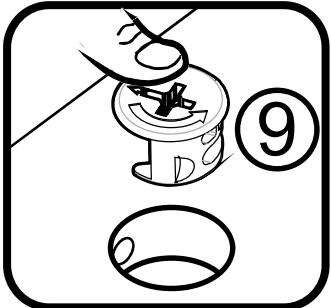
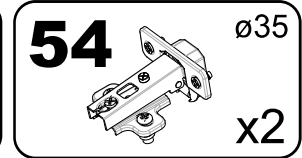
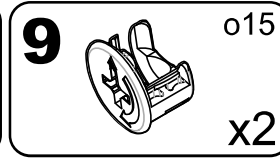
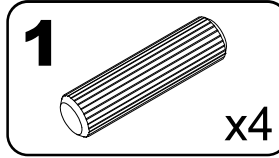

4

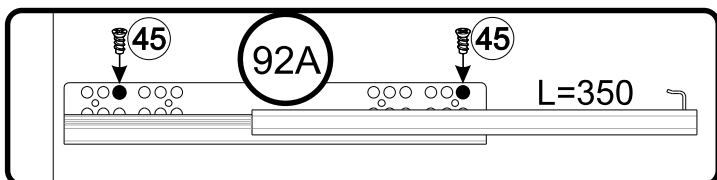
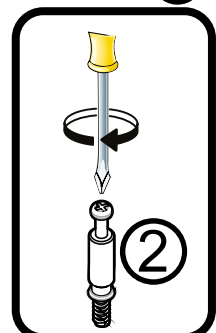
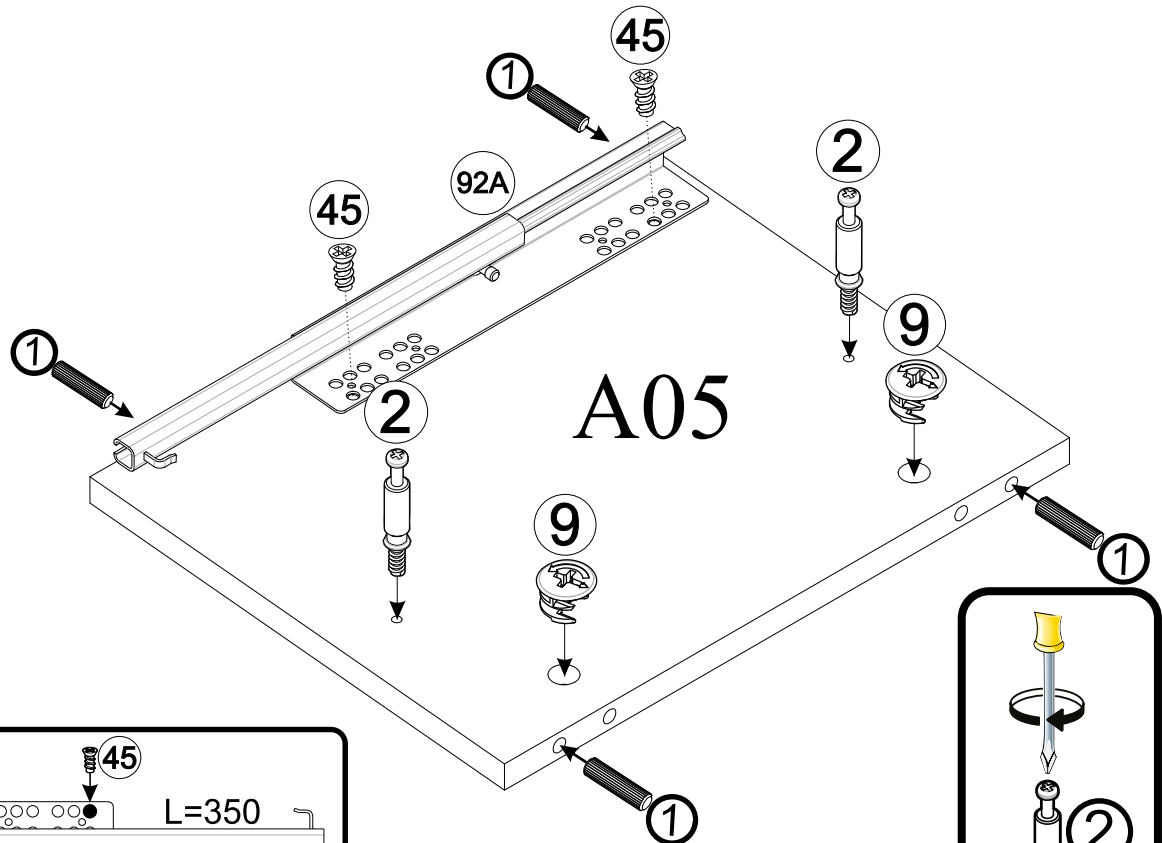
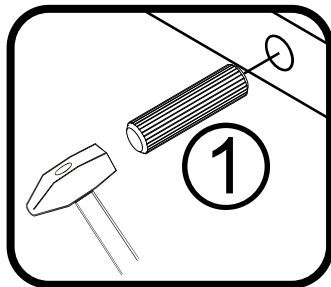
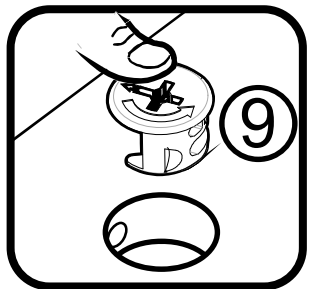
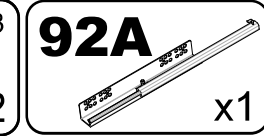
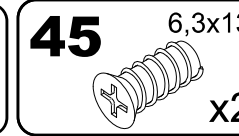
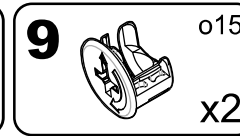
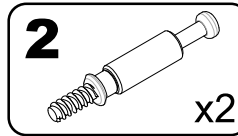
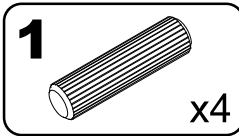

5

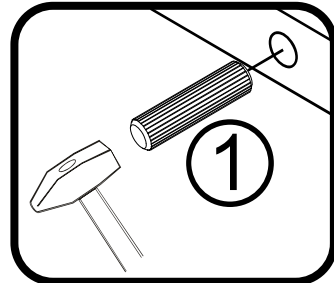
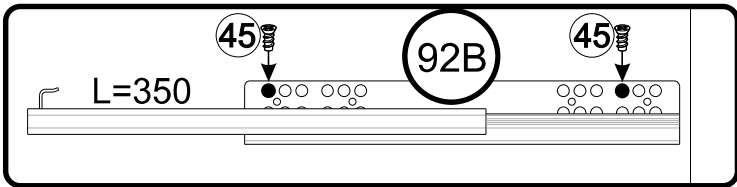
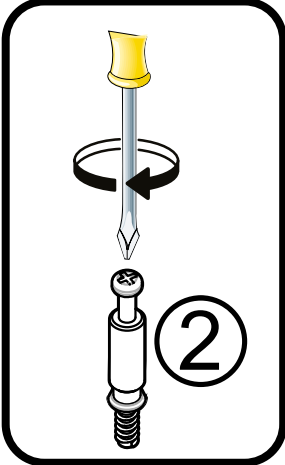
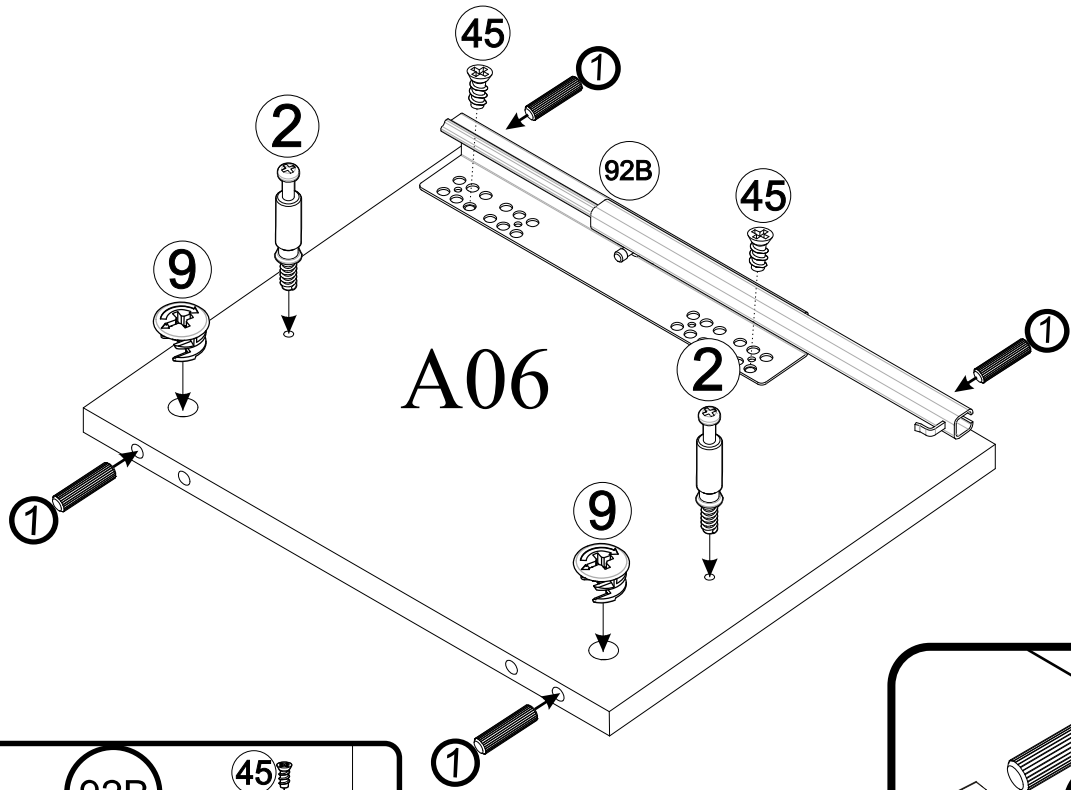
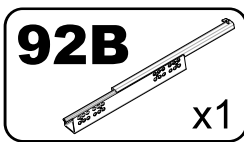
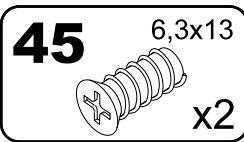
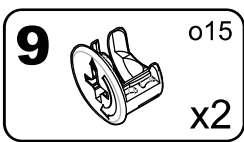
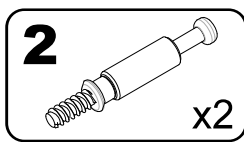
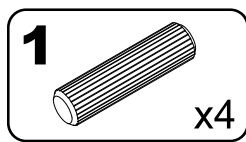

6

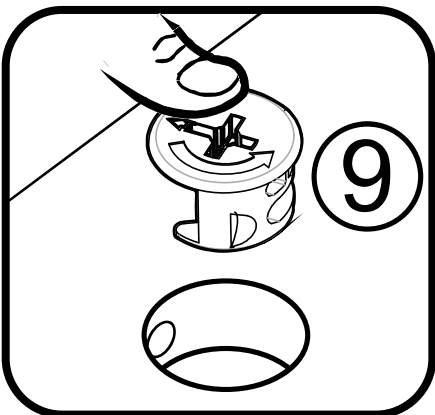
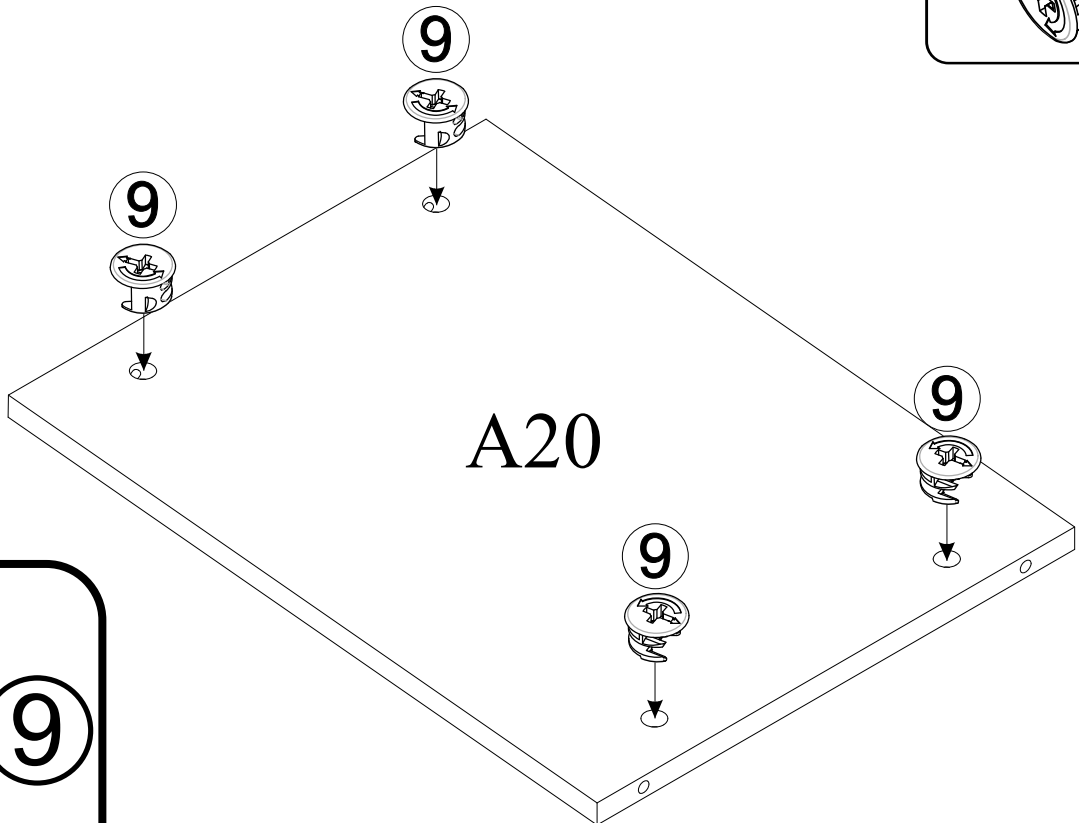
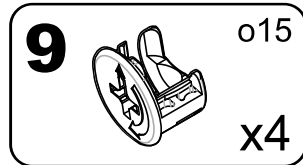

7

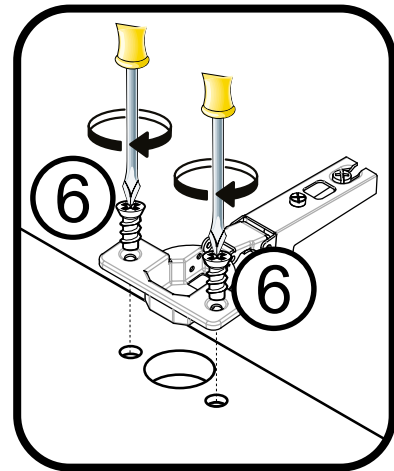
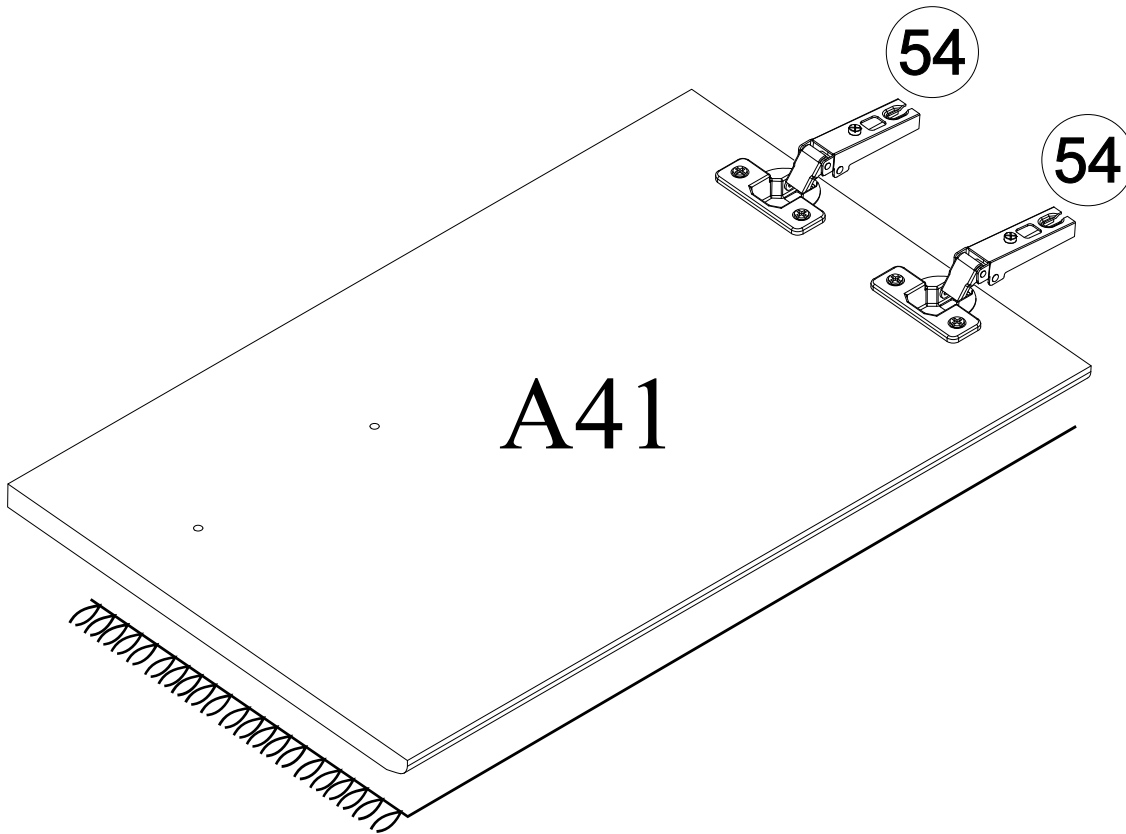
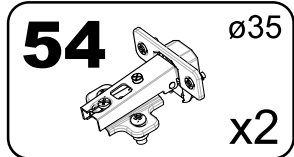
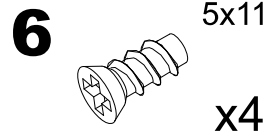

8

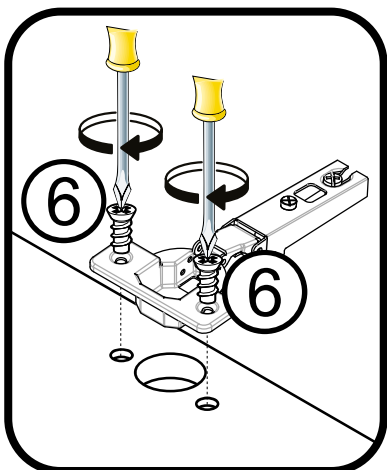
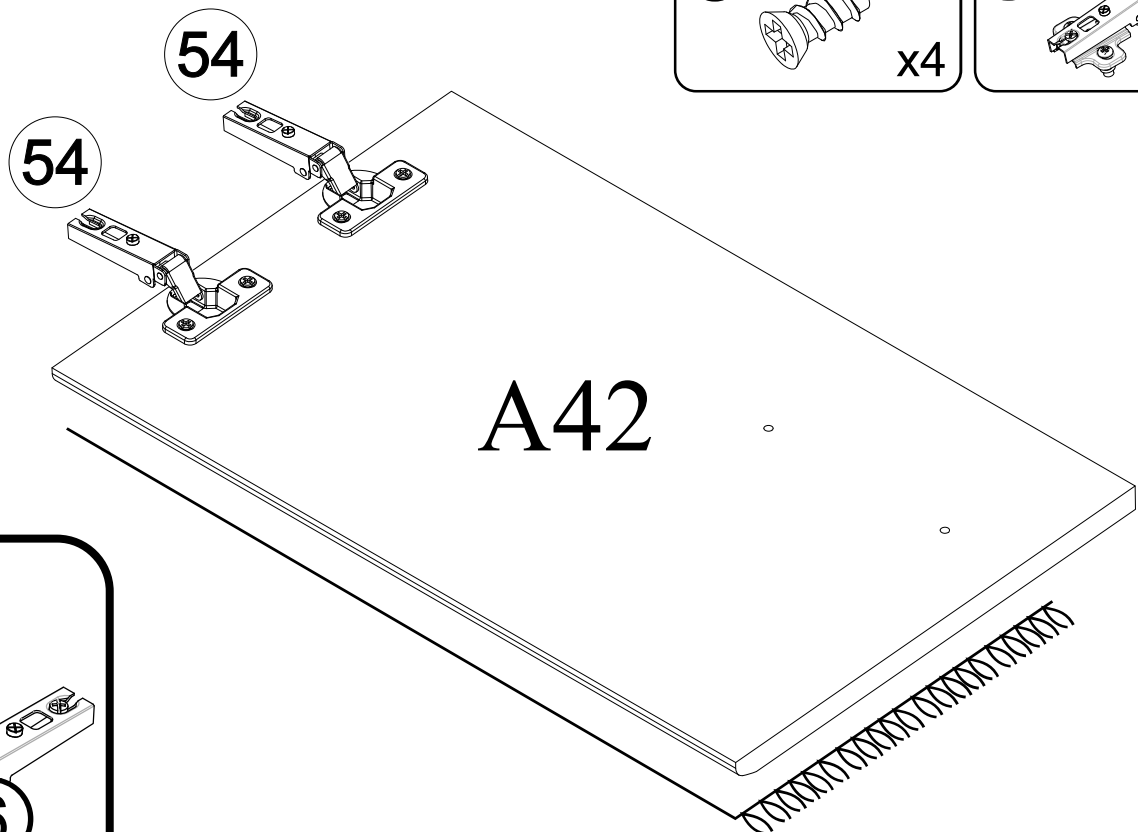
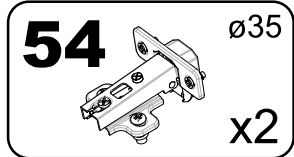
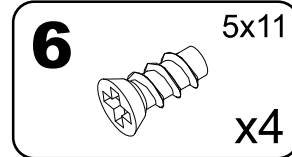

9

2

2

x2

AS1

2

2

24h



10

1

x4

22

x2

24

ø12

x2

26

22

AT1

WQ2

WQ1

8 / 37

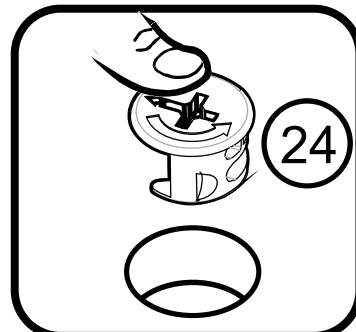
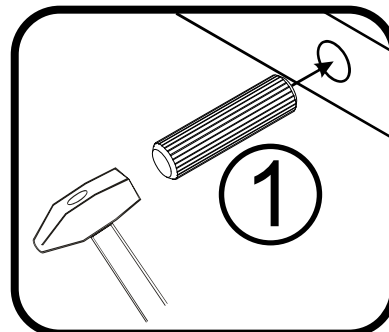

11

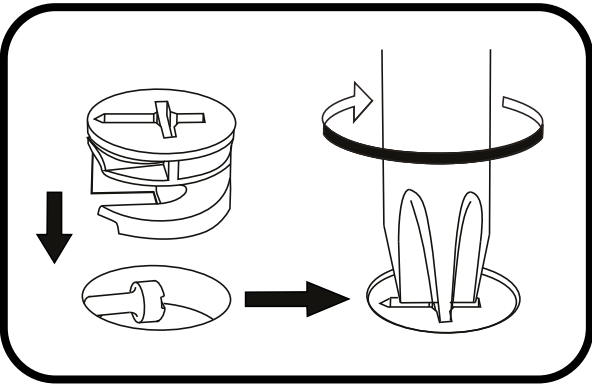
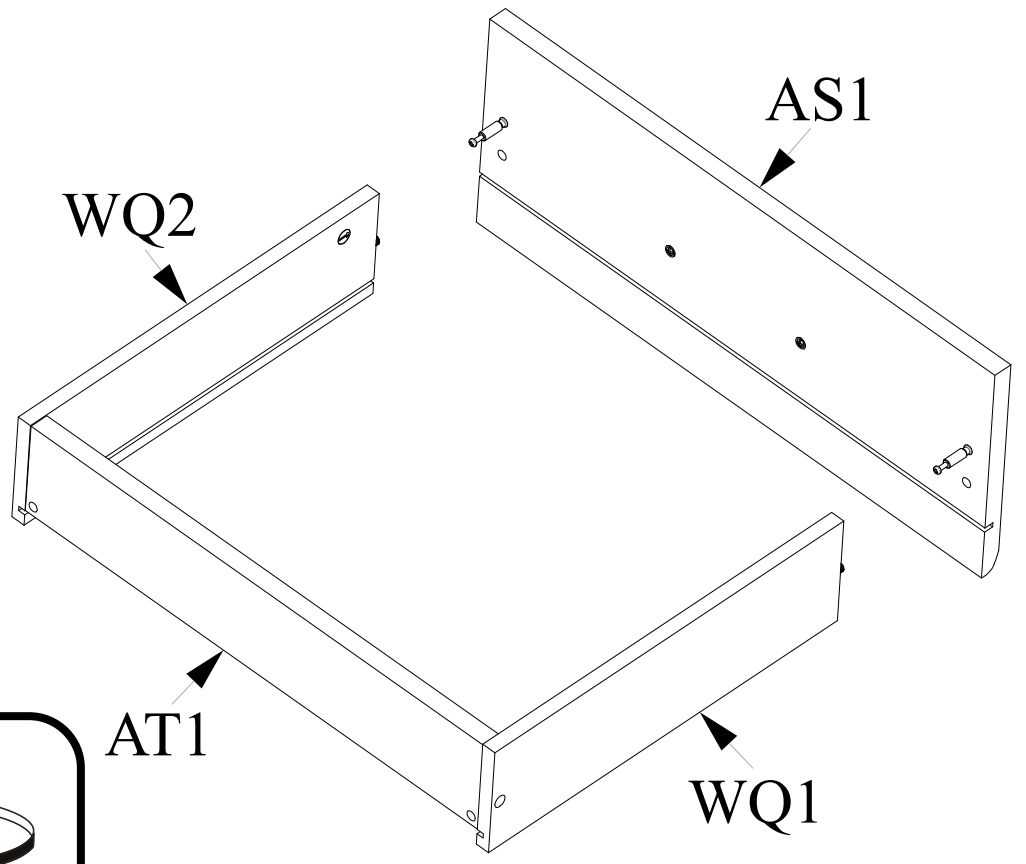

12

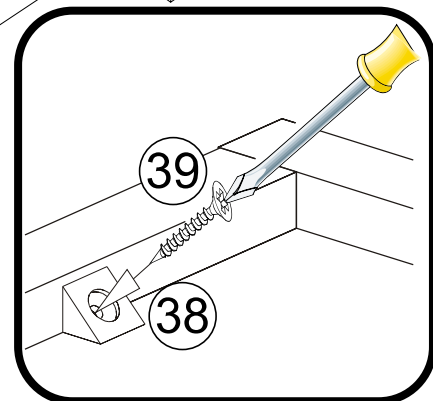
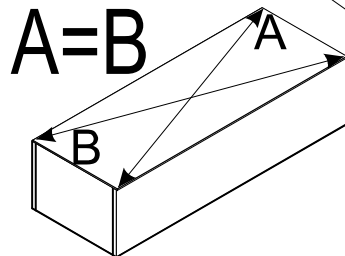
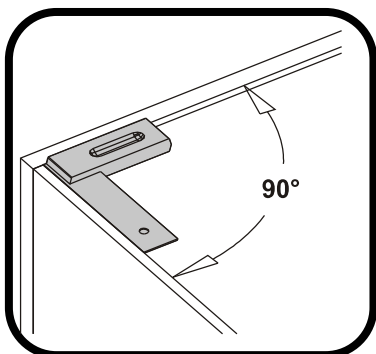
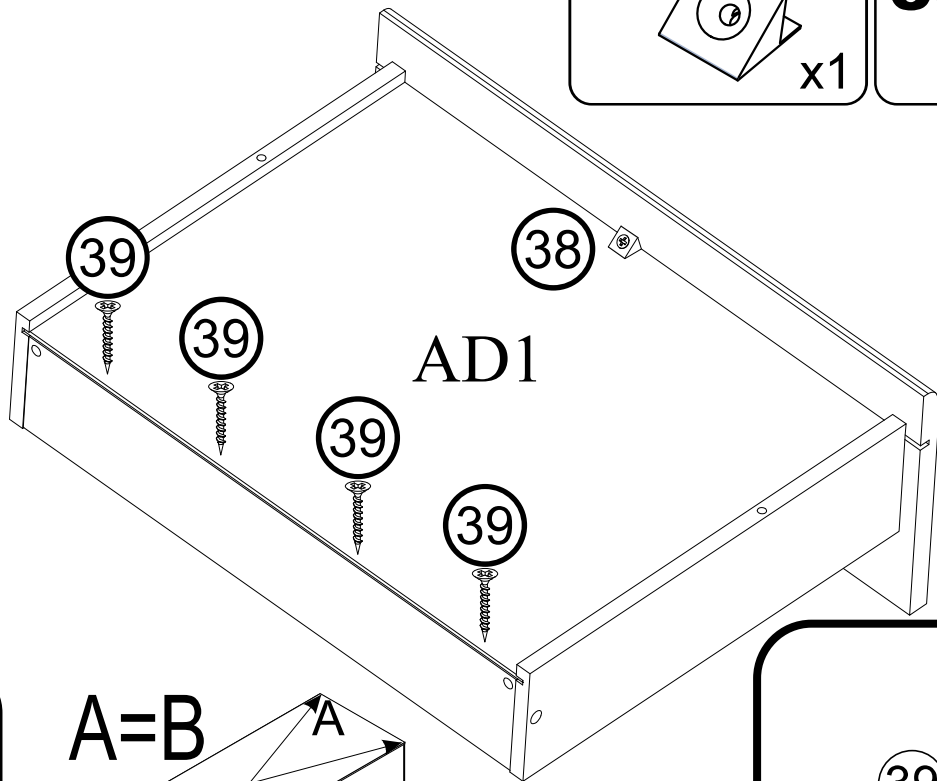
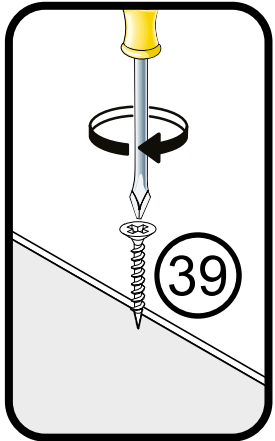
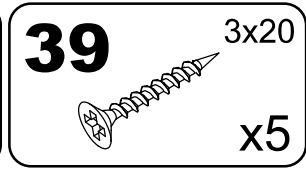
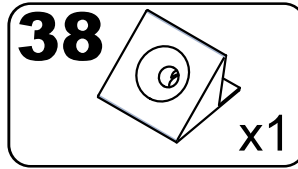

13

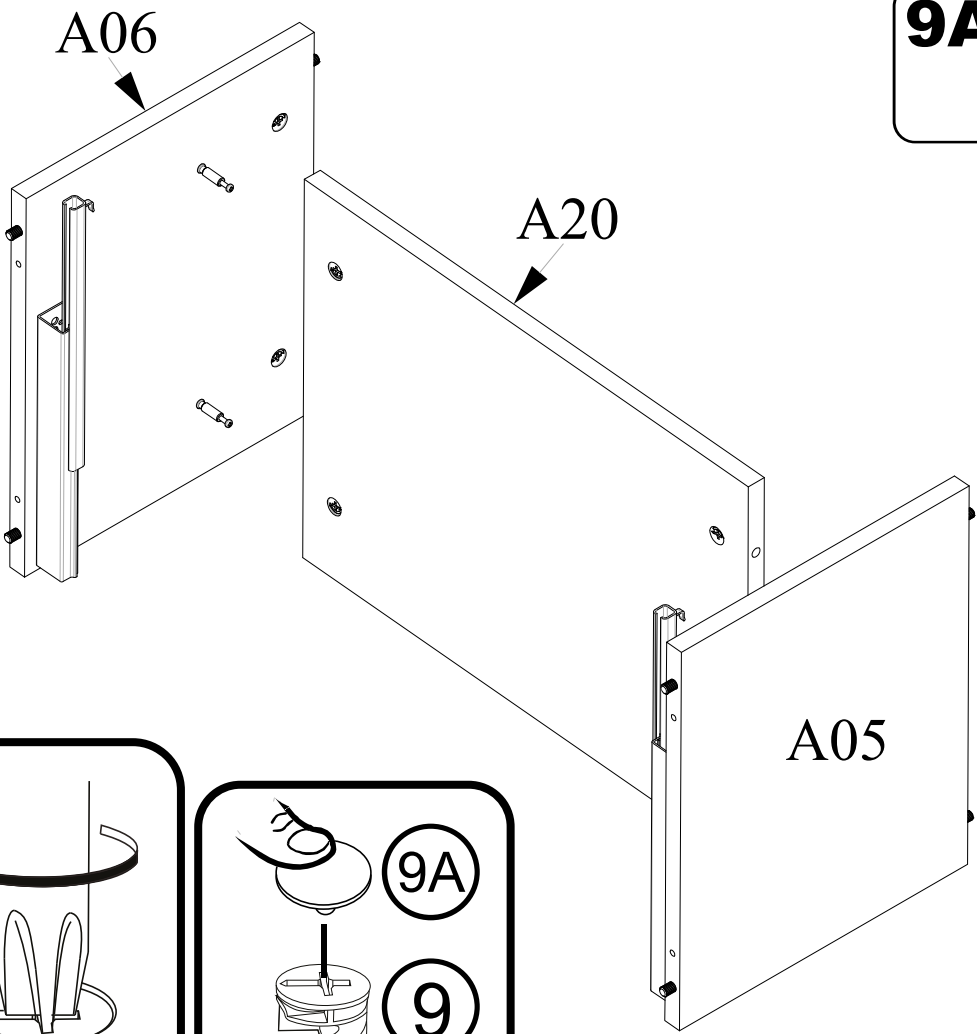

9A  x4

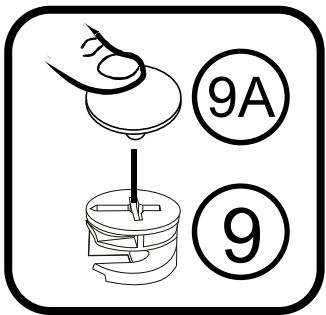
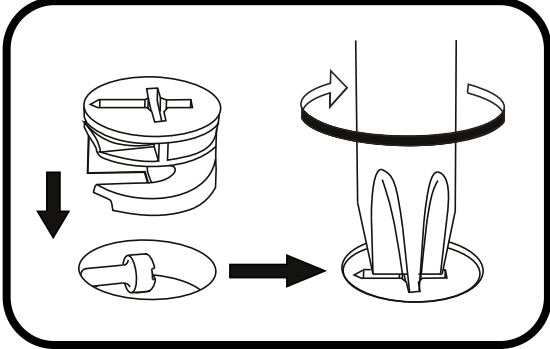

14

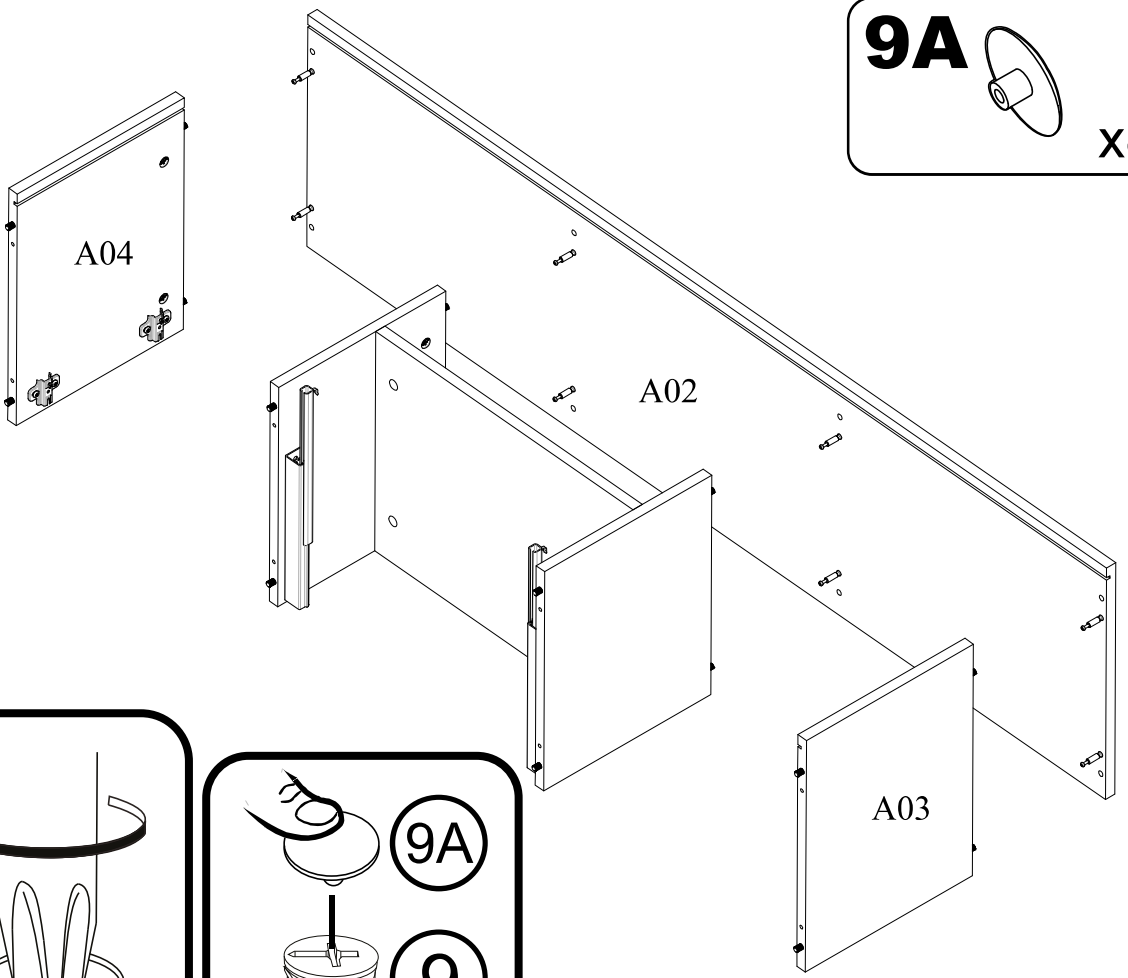

9A  x8

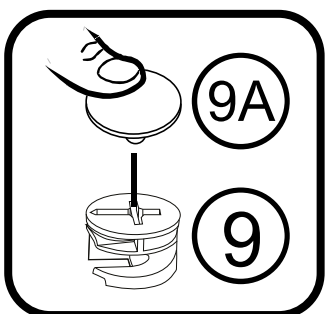
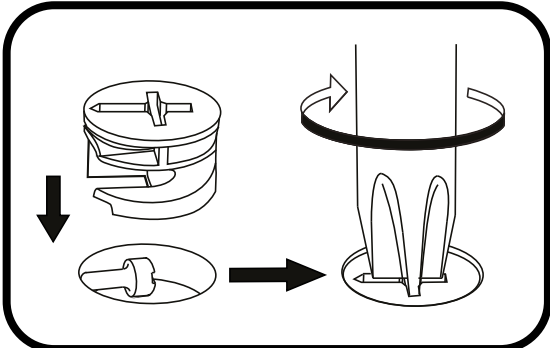

15

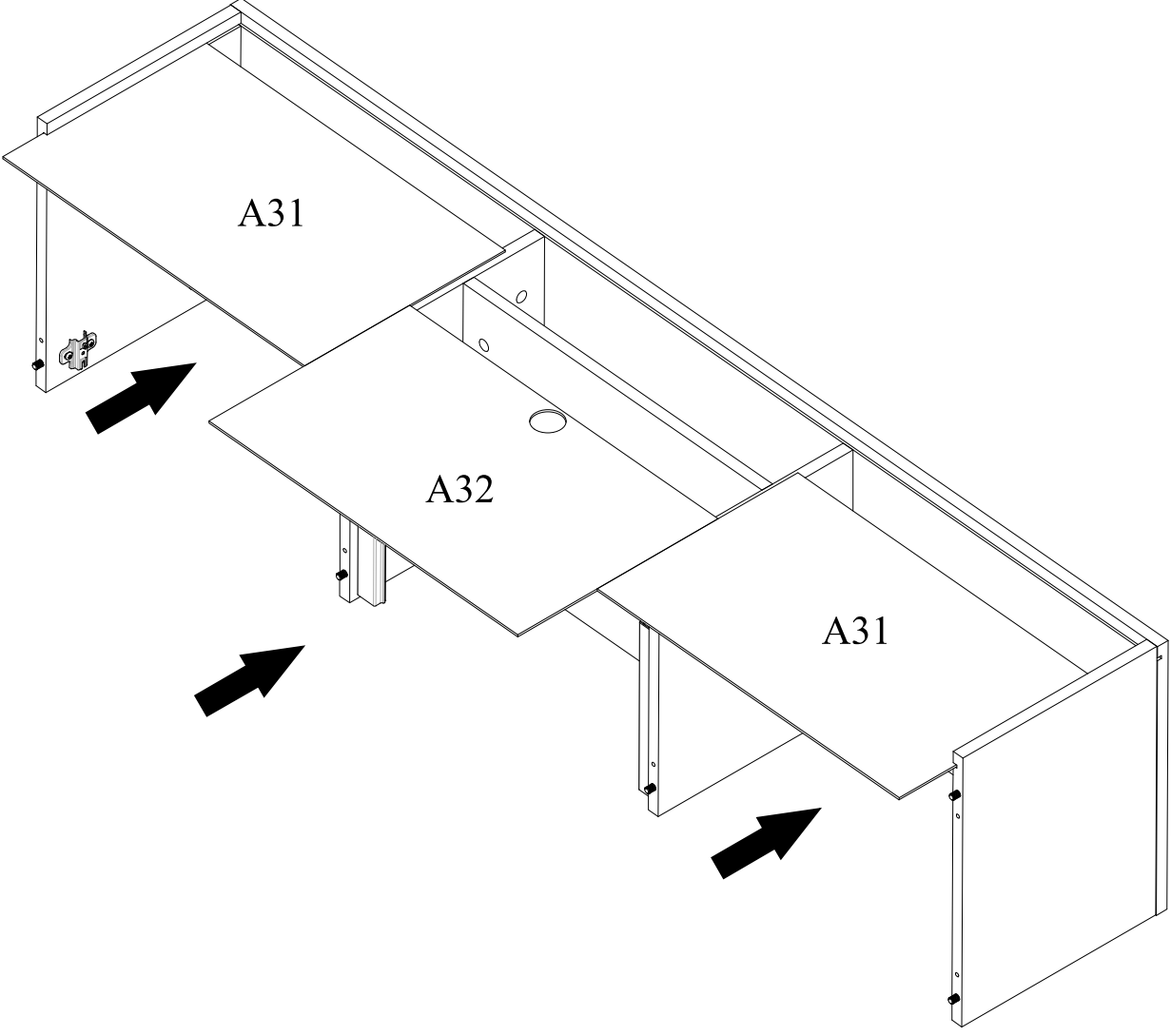

16

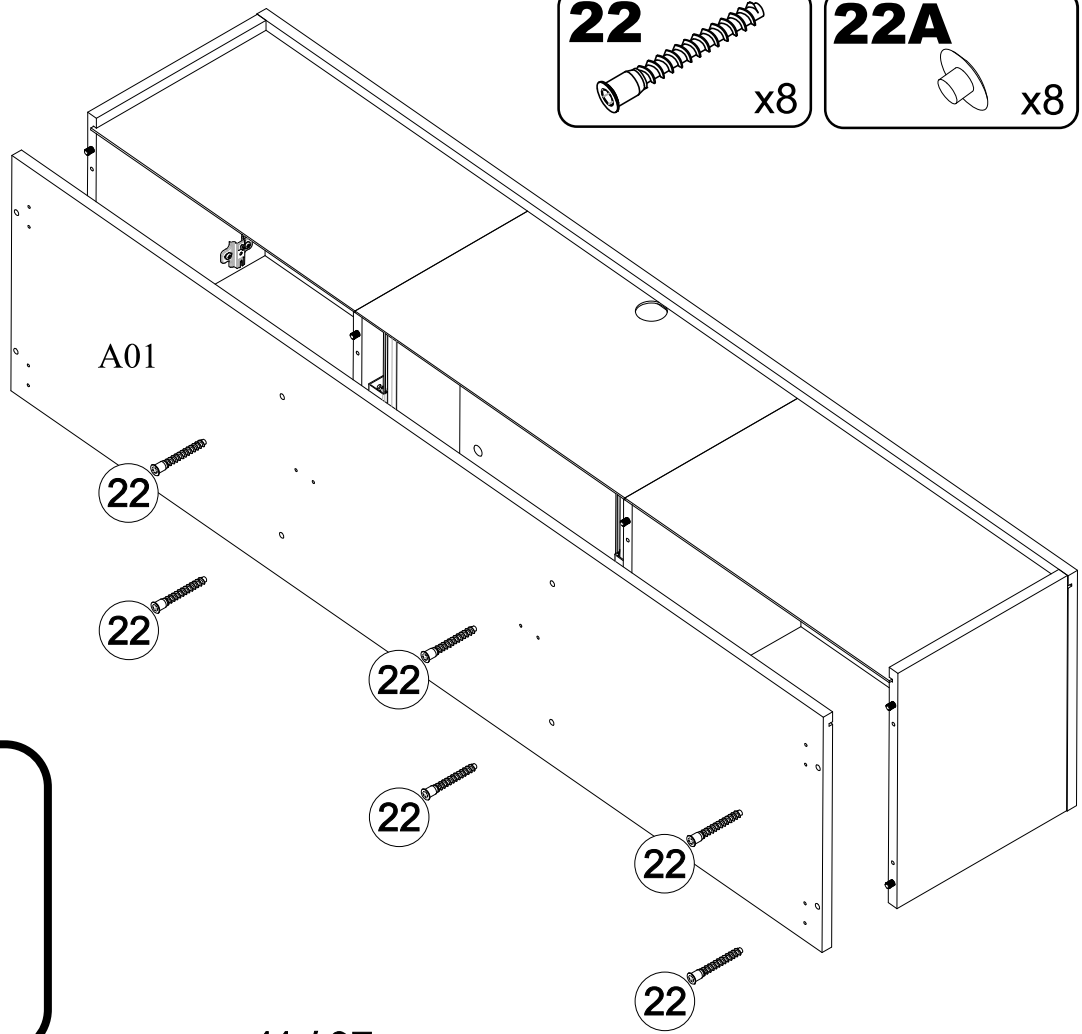
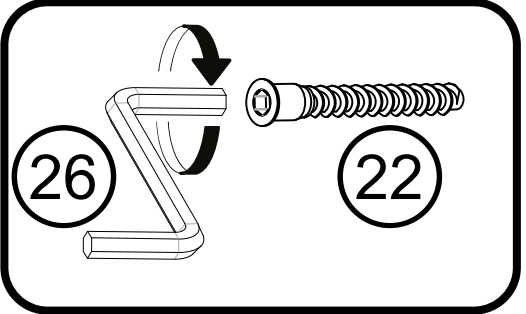
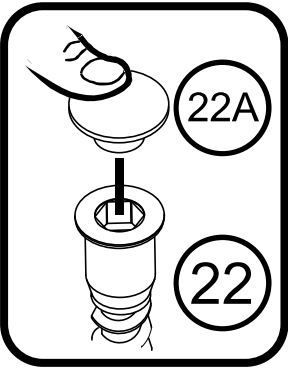
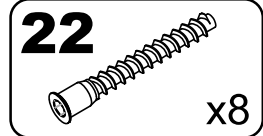

17

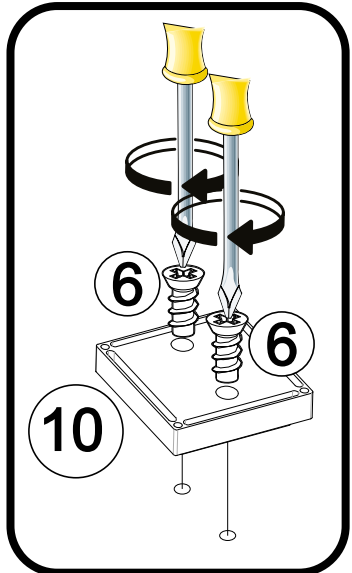
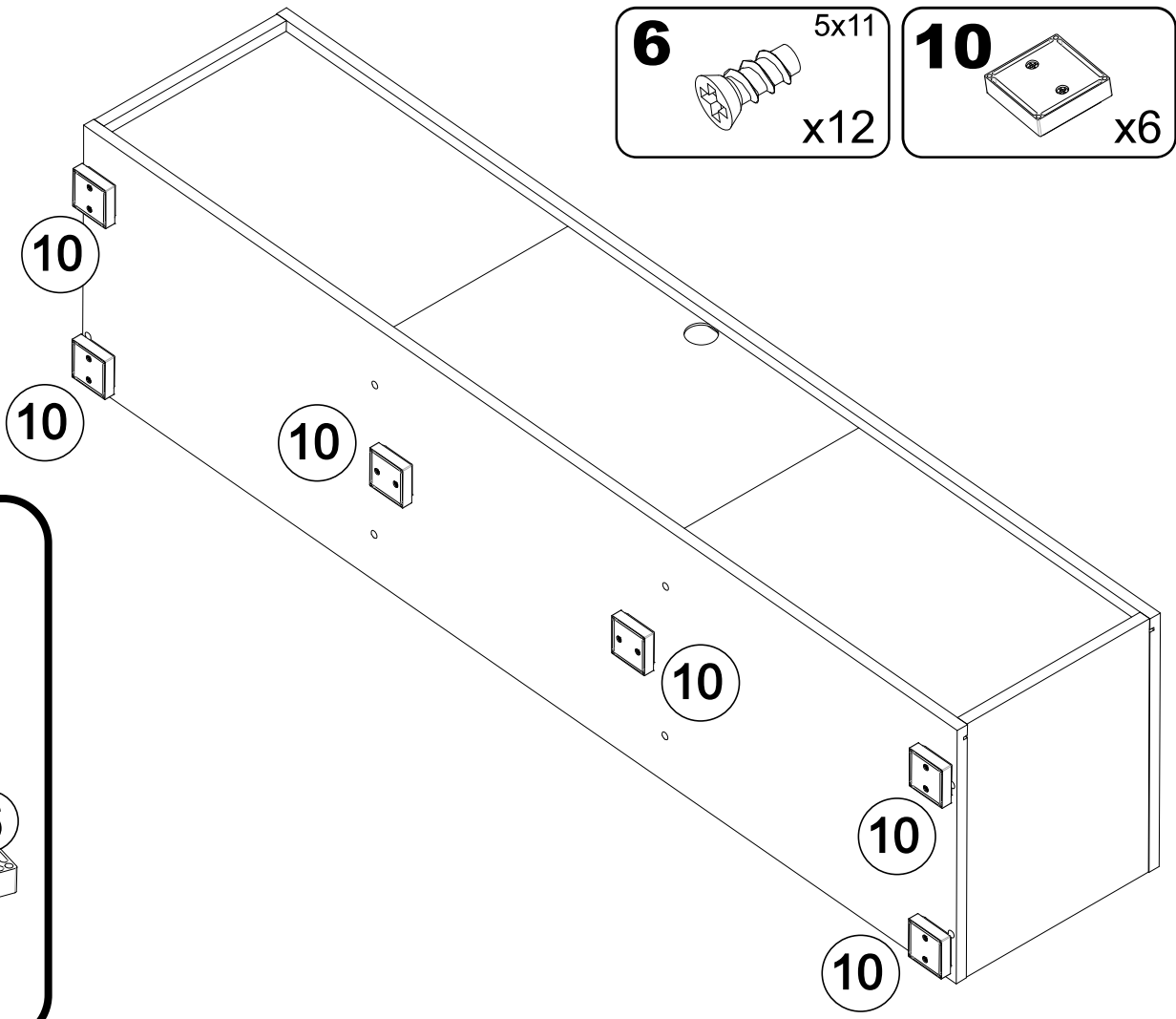
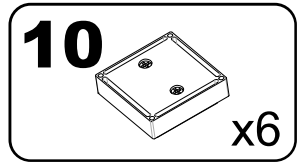
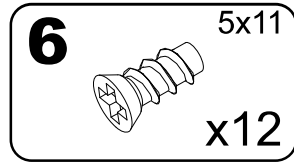

18

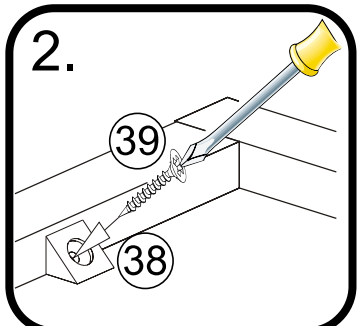
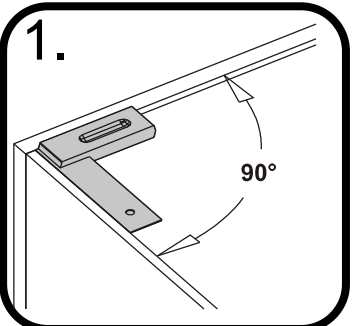
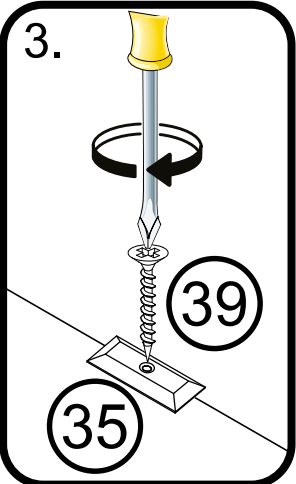
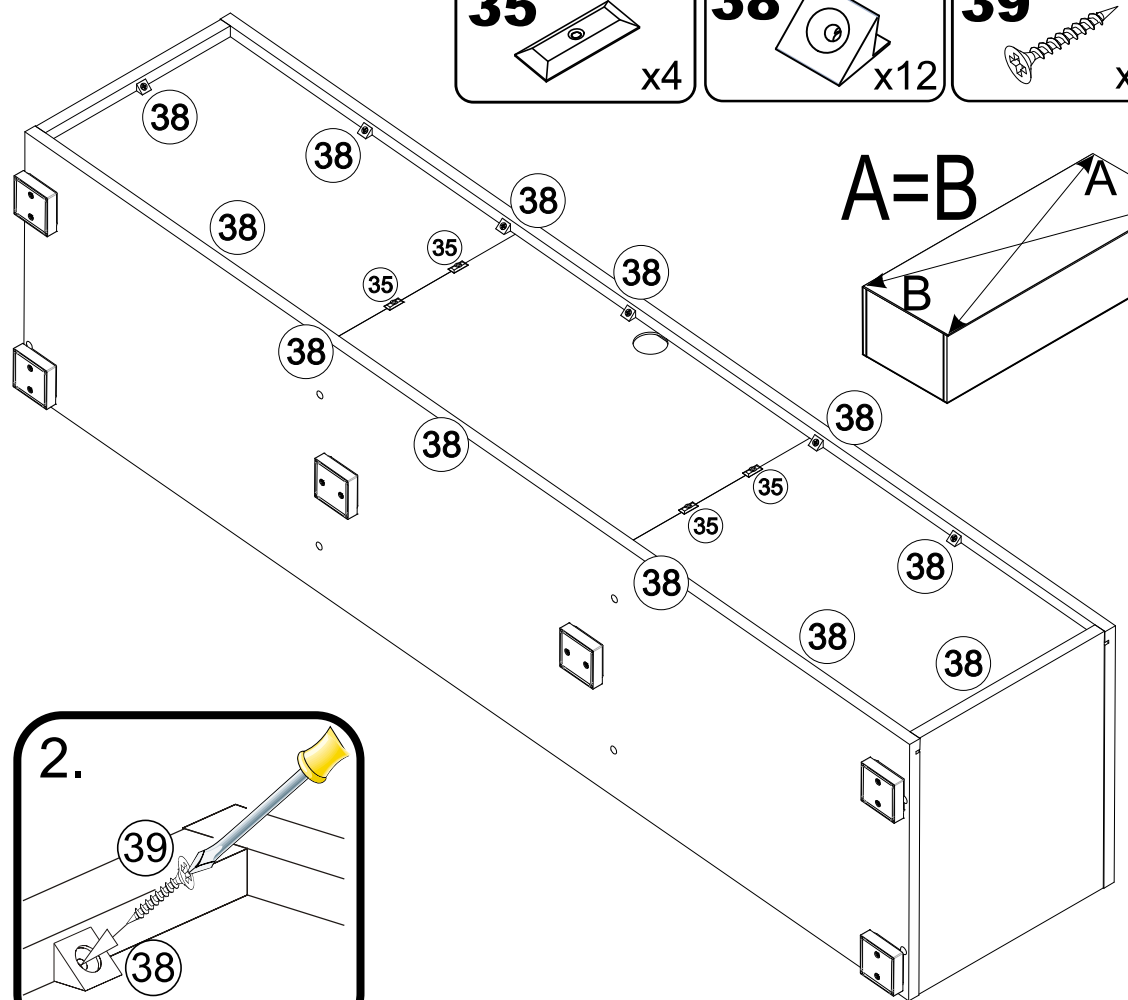
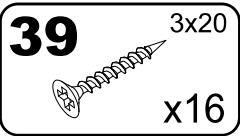
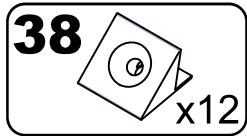
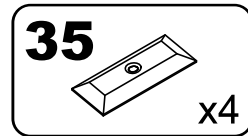

19

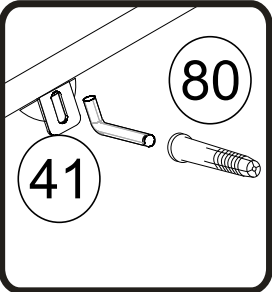
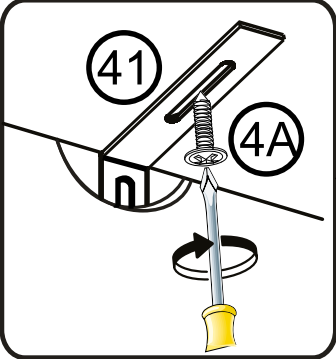
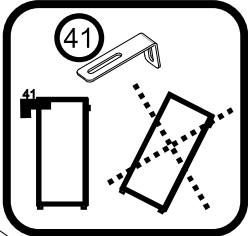
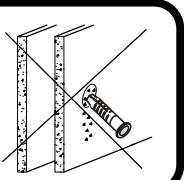
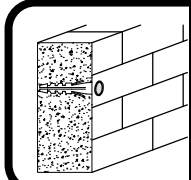
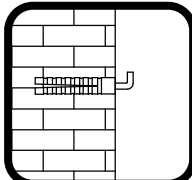
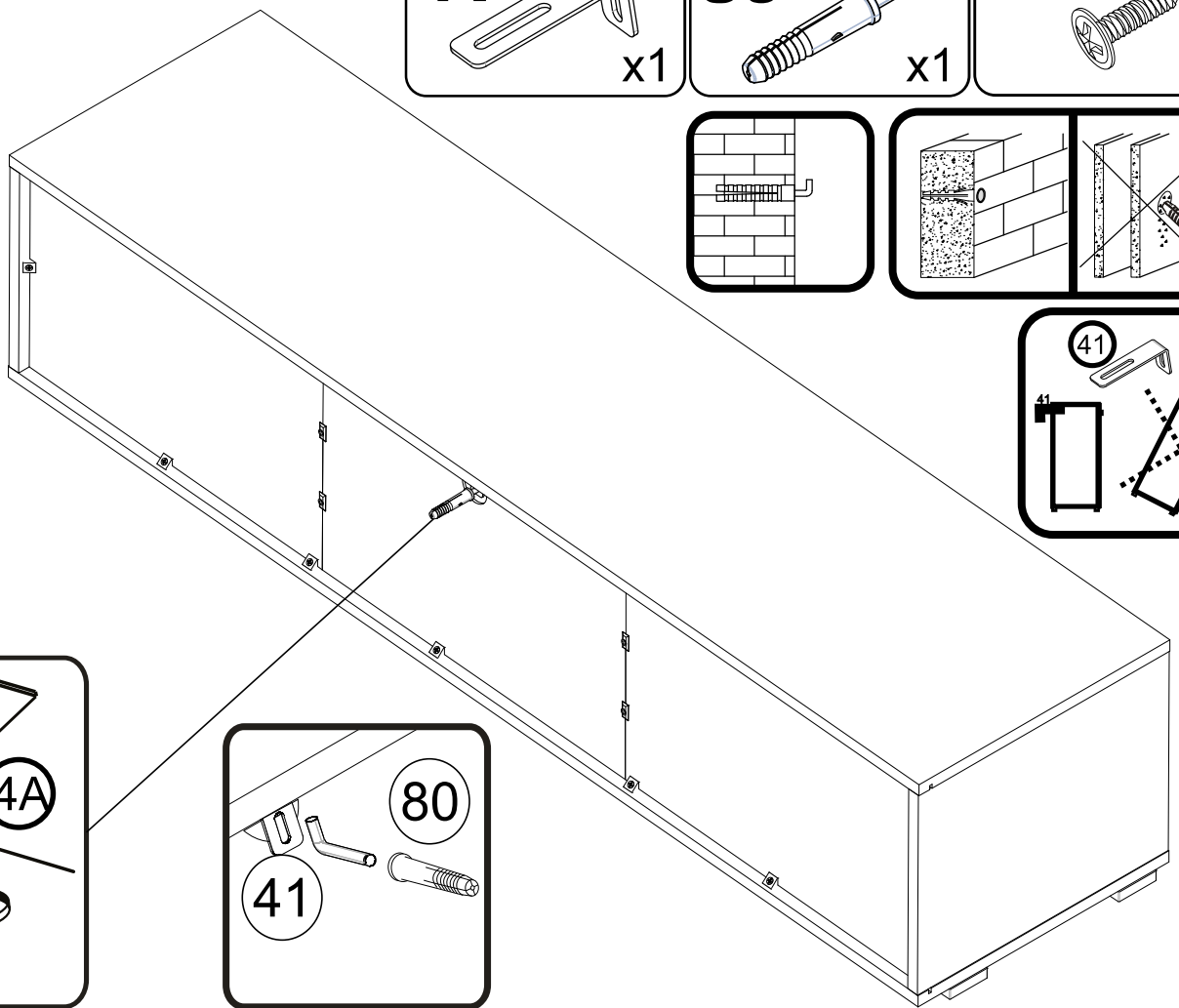
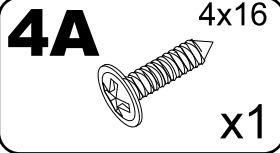
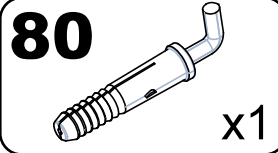
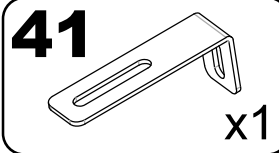

20

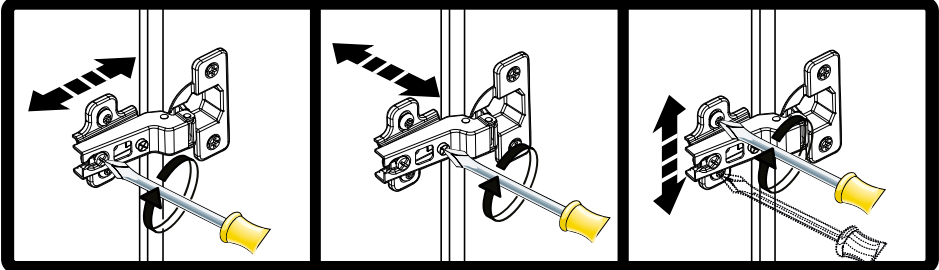
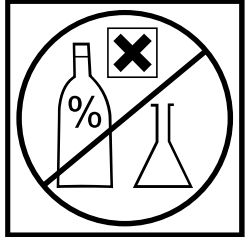
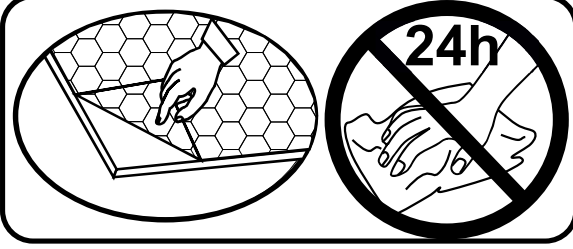
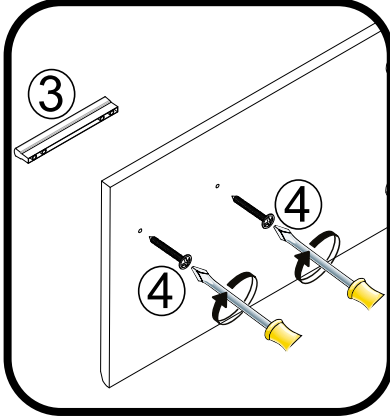
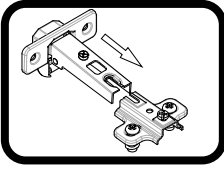
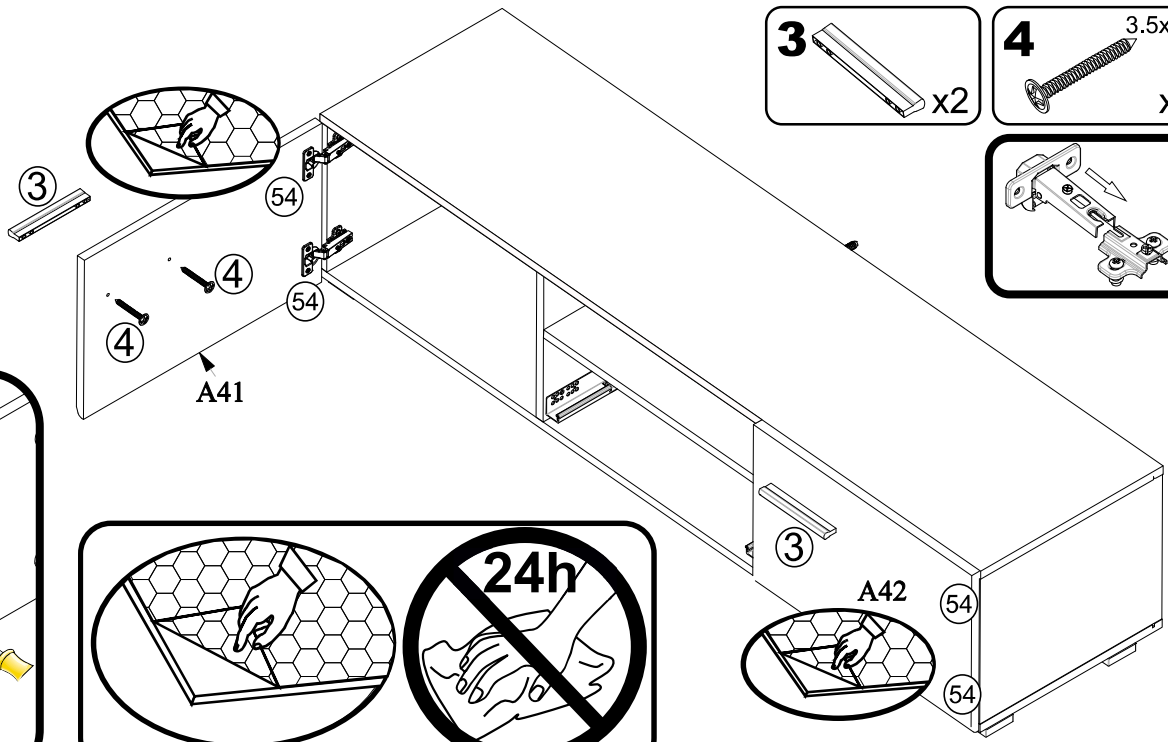
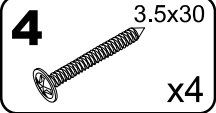
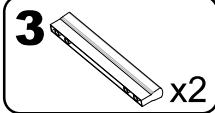

21

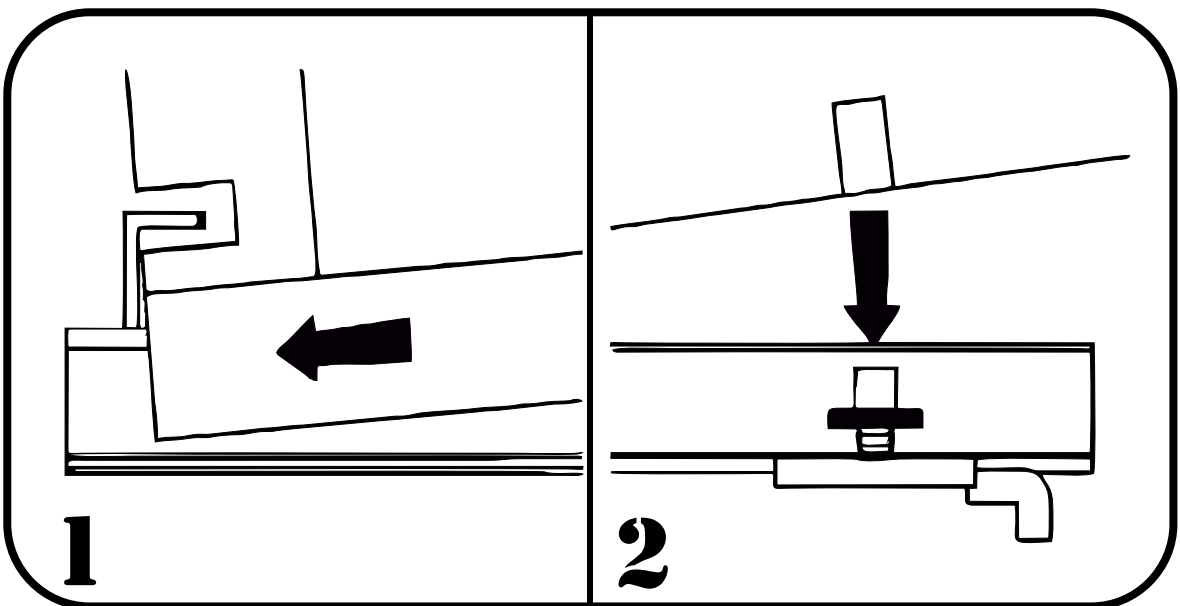
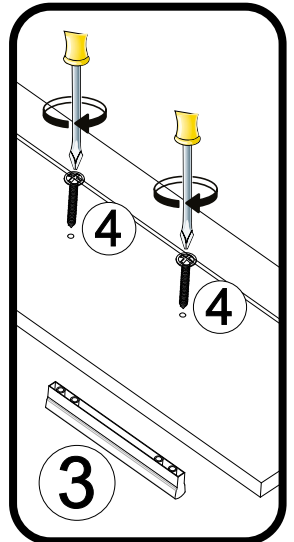
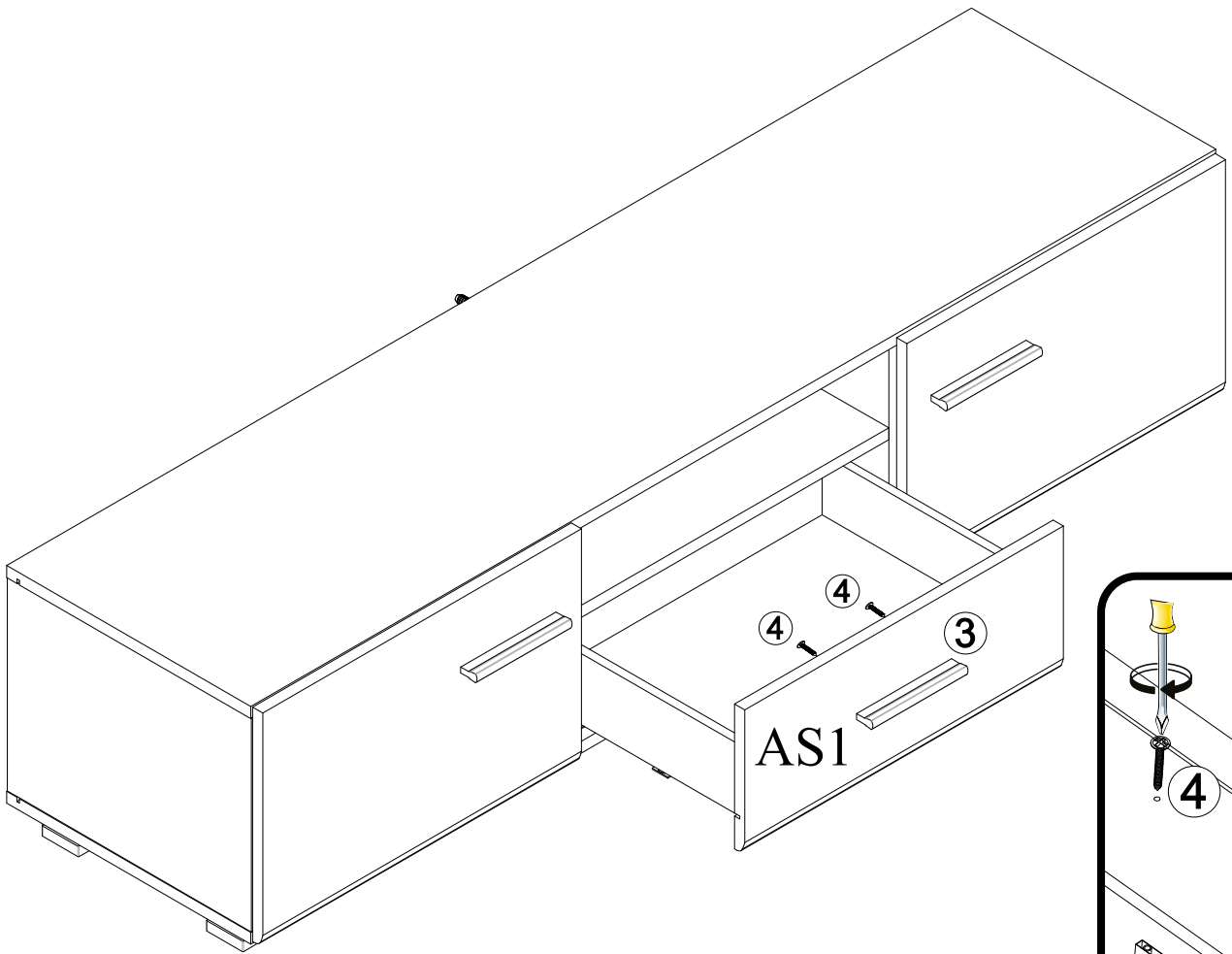
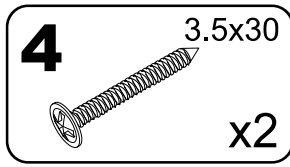
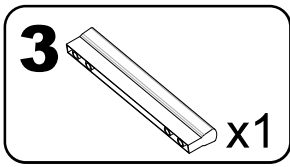

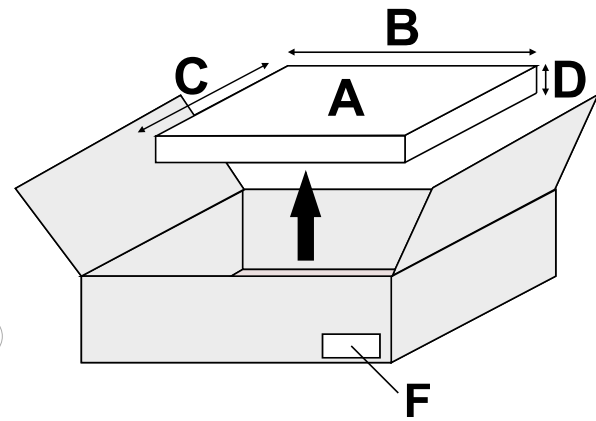
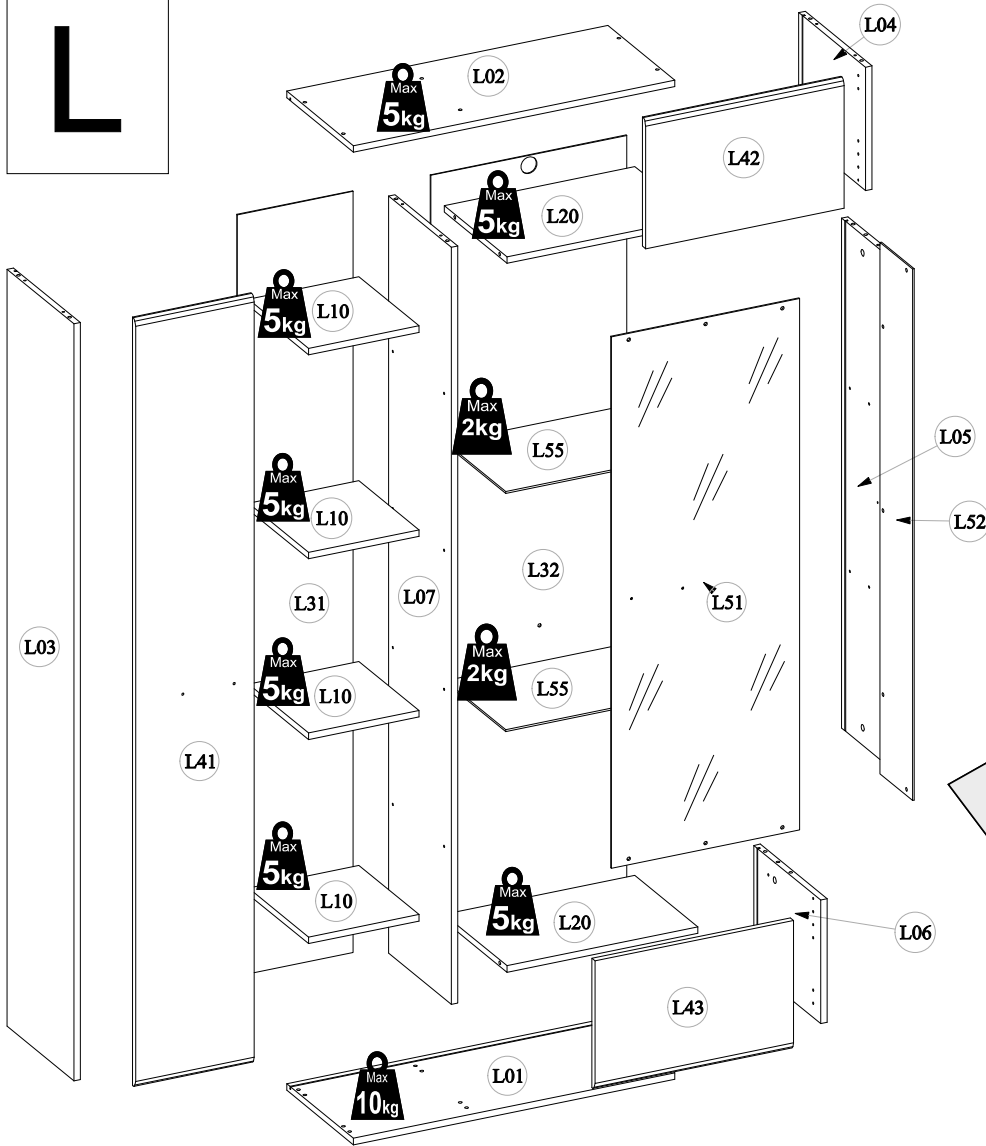
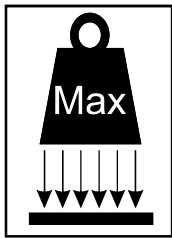
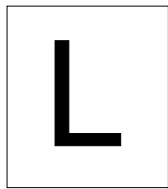

A	B (mm)	C (mm)	D (mm)	E	F
L01	802	334	16	1	3/5
L02	802	334	16	1	3/5
L03	1852	334	16	1	3/5
L04	302	334	16	1	3/5
L05	1248	195	16	1	3/5
L06	302	334	16	1	3/5
L07	1852	314	16	1	3/5
L10	276	300	16	4	3/5
L20	476	314	16	2	4/5
L31	1862	289	3	1	4/5
L32	1862	489	3	1	4/5
L41	1880	296	16	1	4/5
L42	316	496	16	1	4/5
L43	316	496	16	1	4/5
L51	1300	470	4	1	4/5
L52	1300	163	4	1	3/5
L55	467	300	5	2	2/5

1

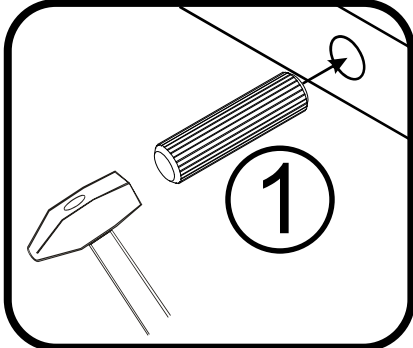
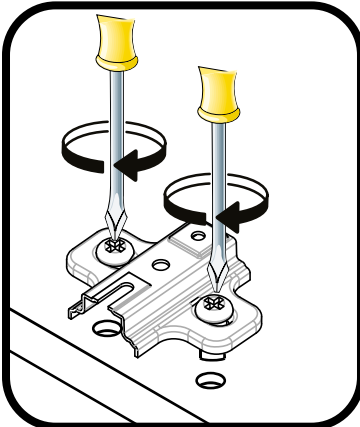
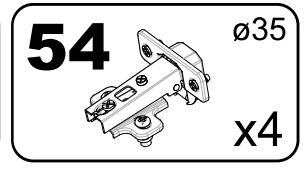
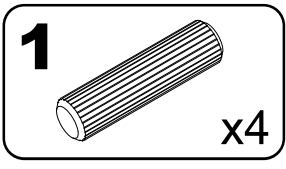
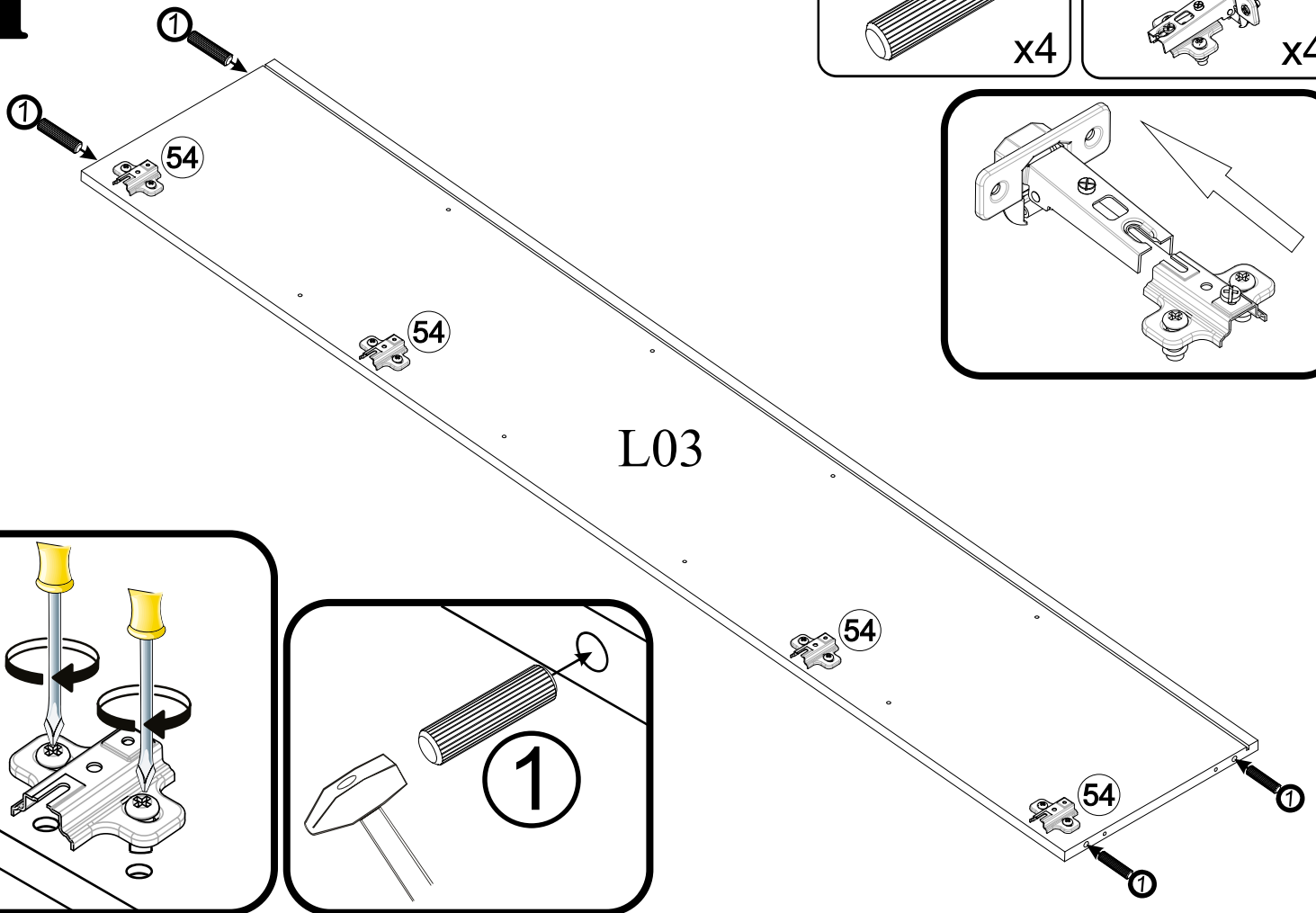

2

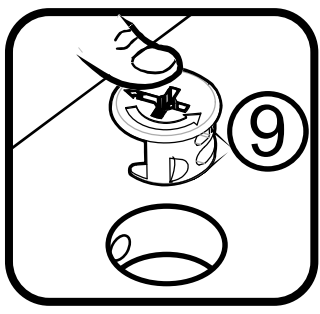
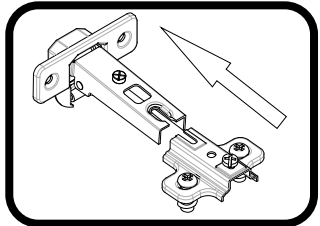
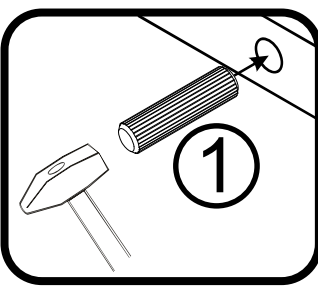
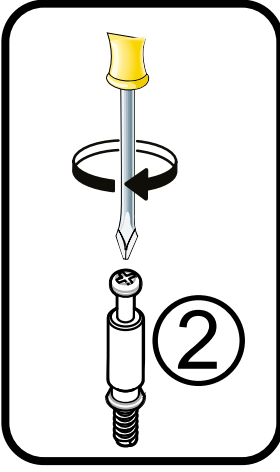
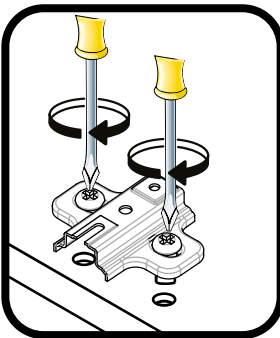
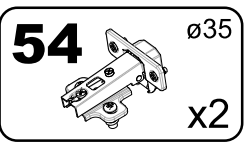
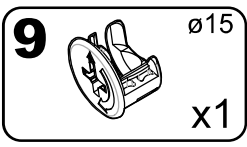
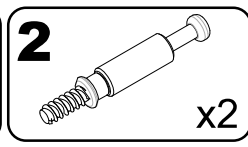
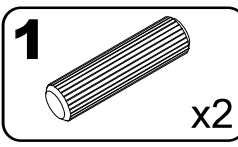
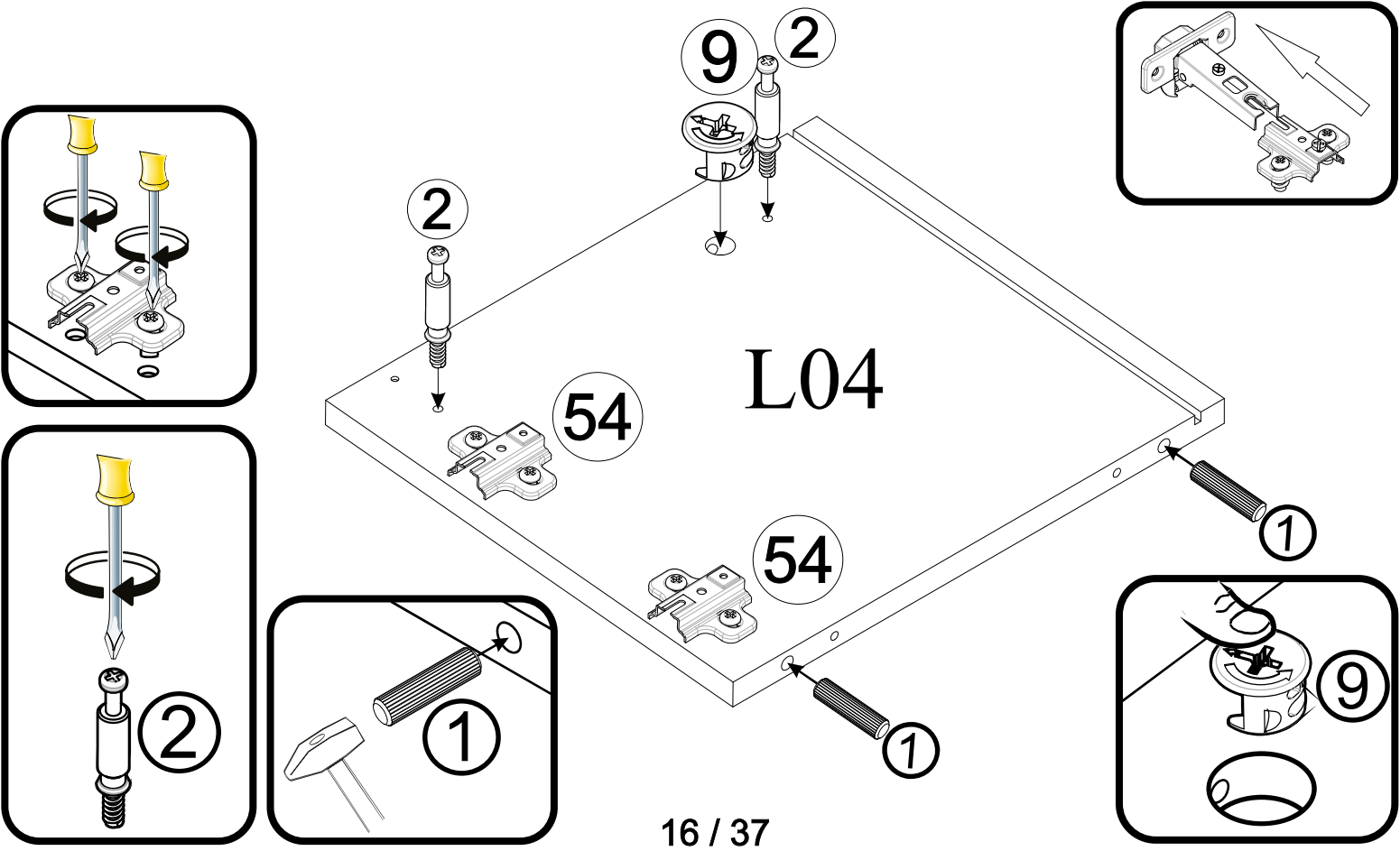

3

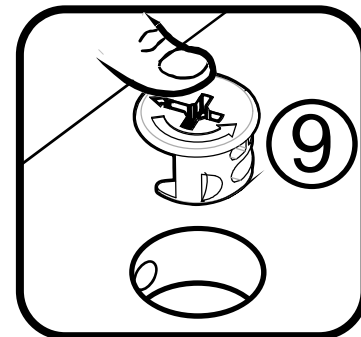
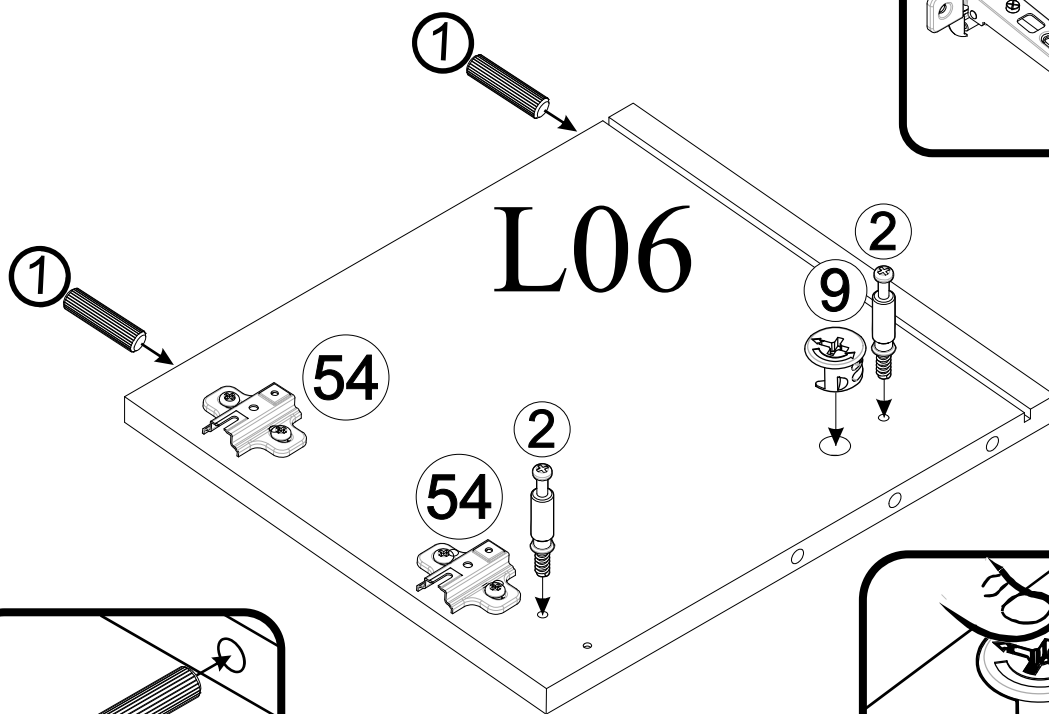
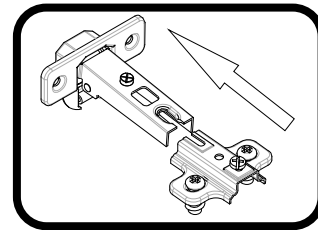
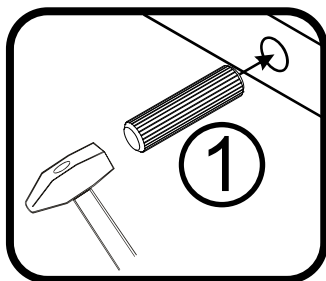
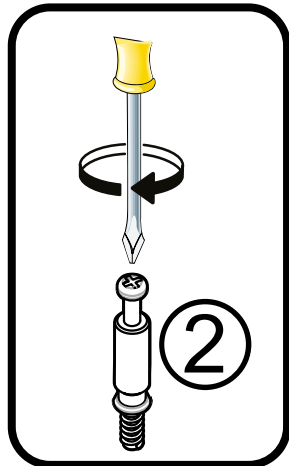
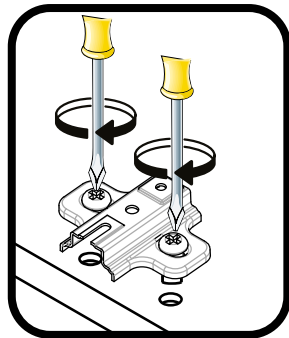
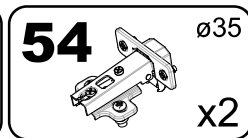
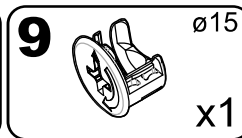
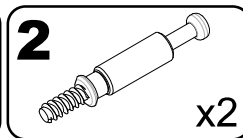
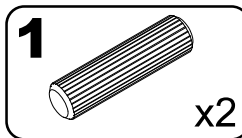

4

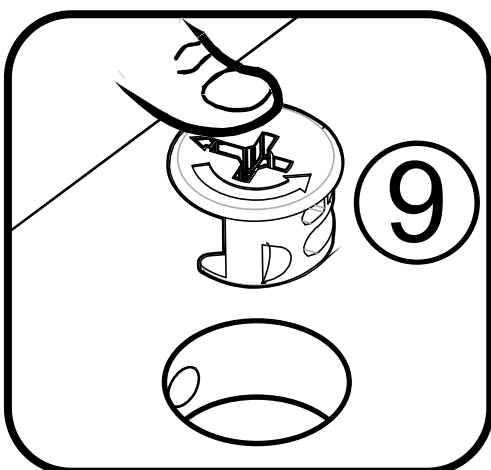
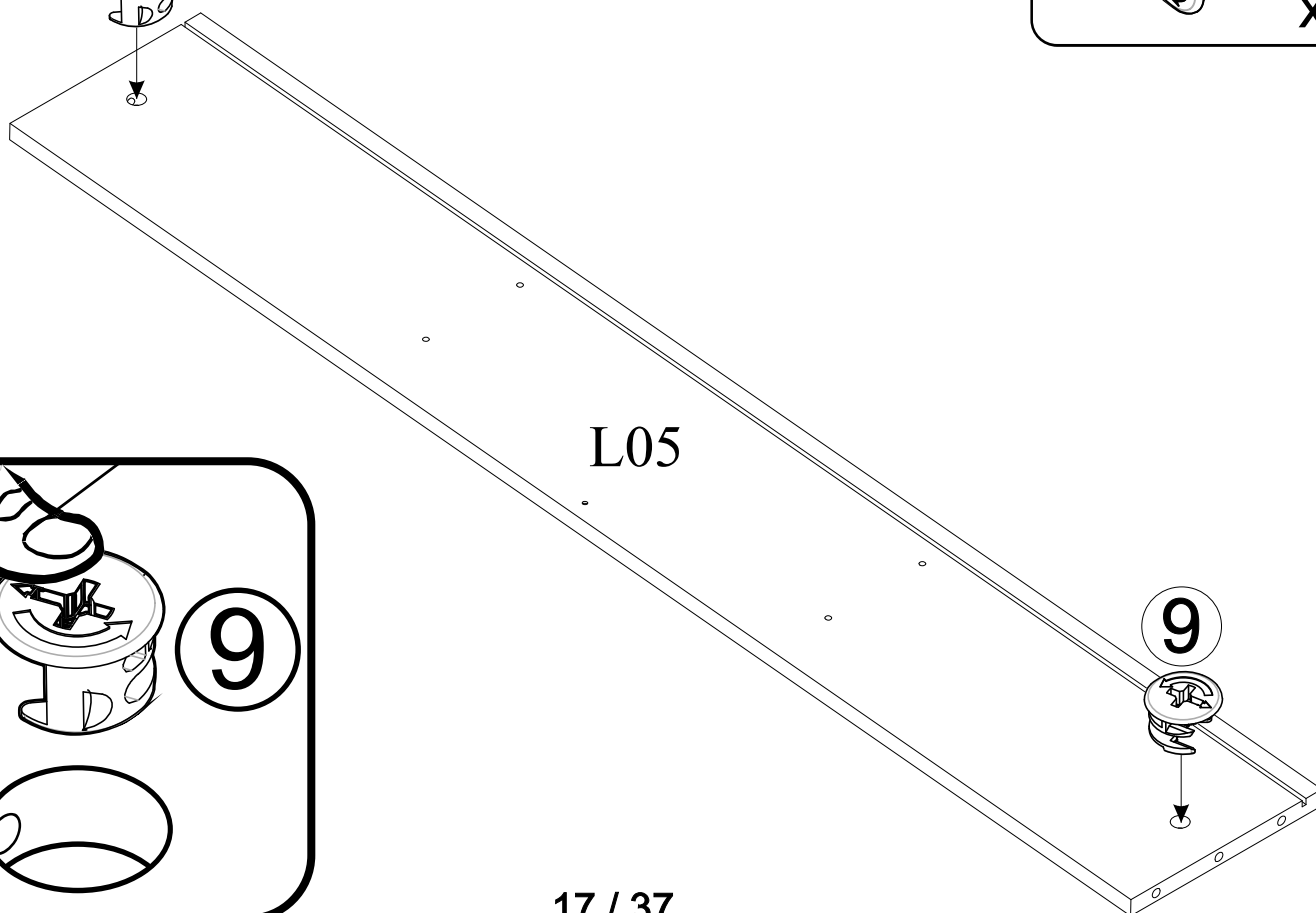
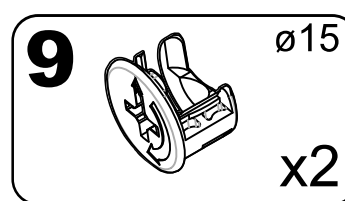

5

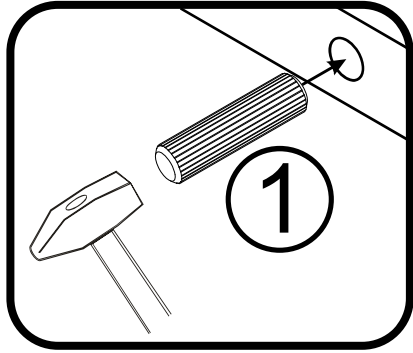
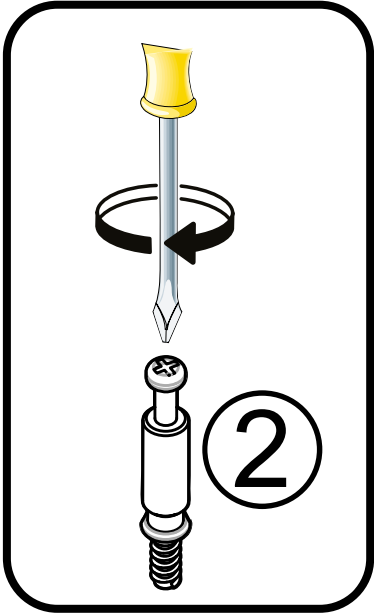
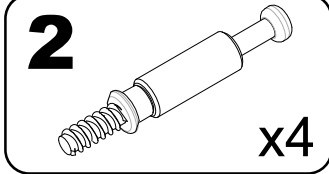
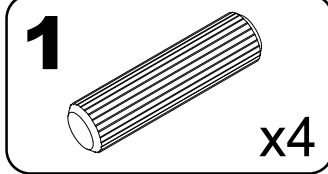
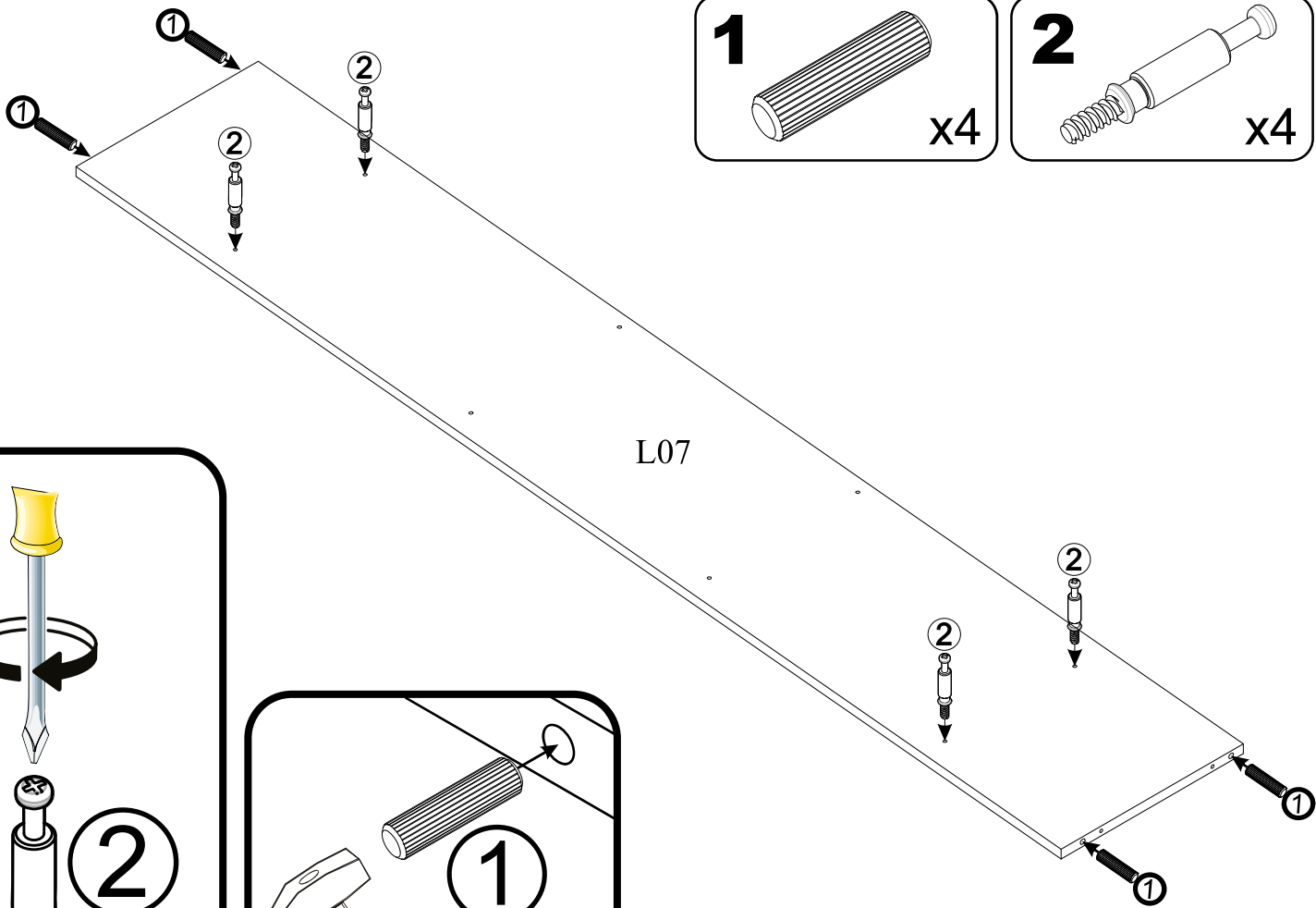

6

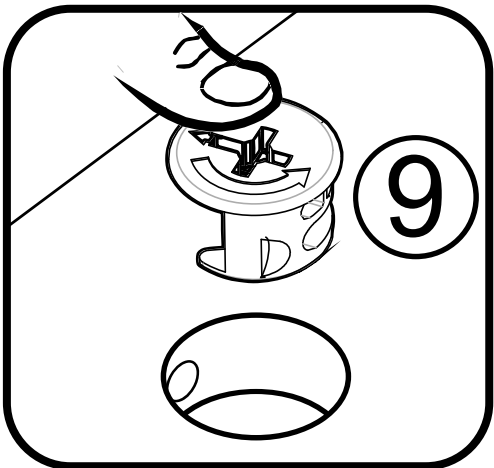
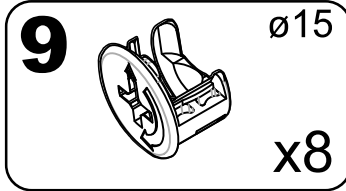
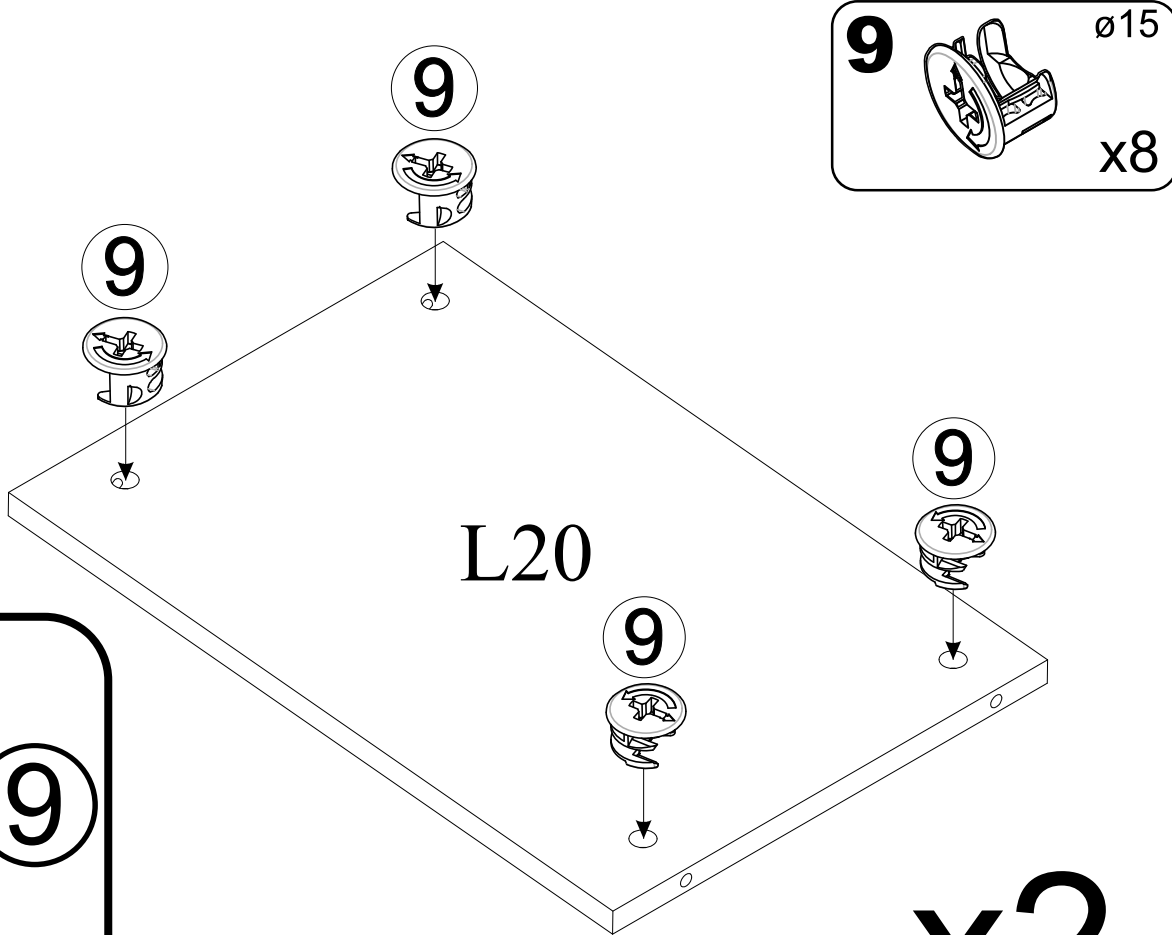

x2

7

6 5x11
x8

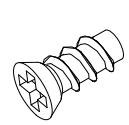

54 ø35
x4

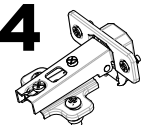
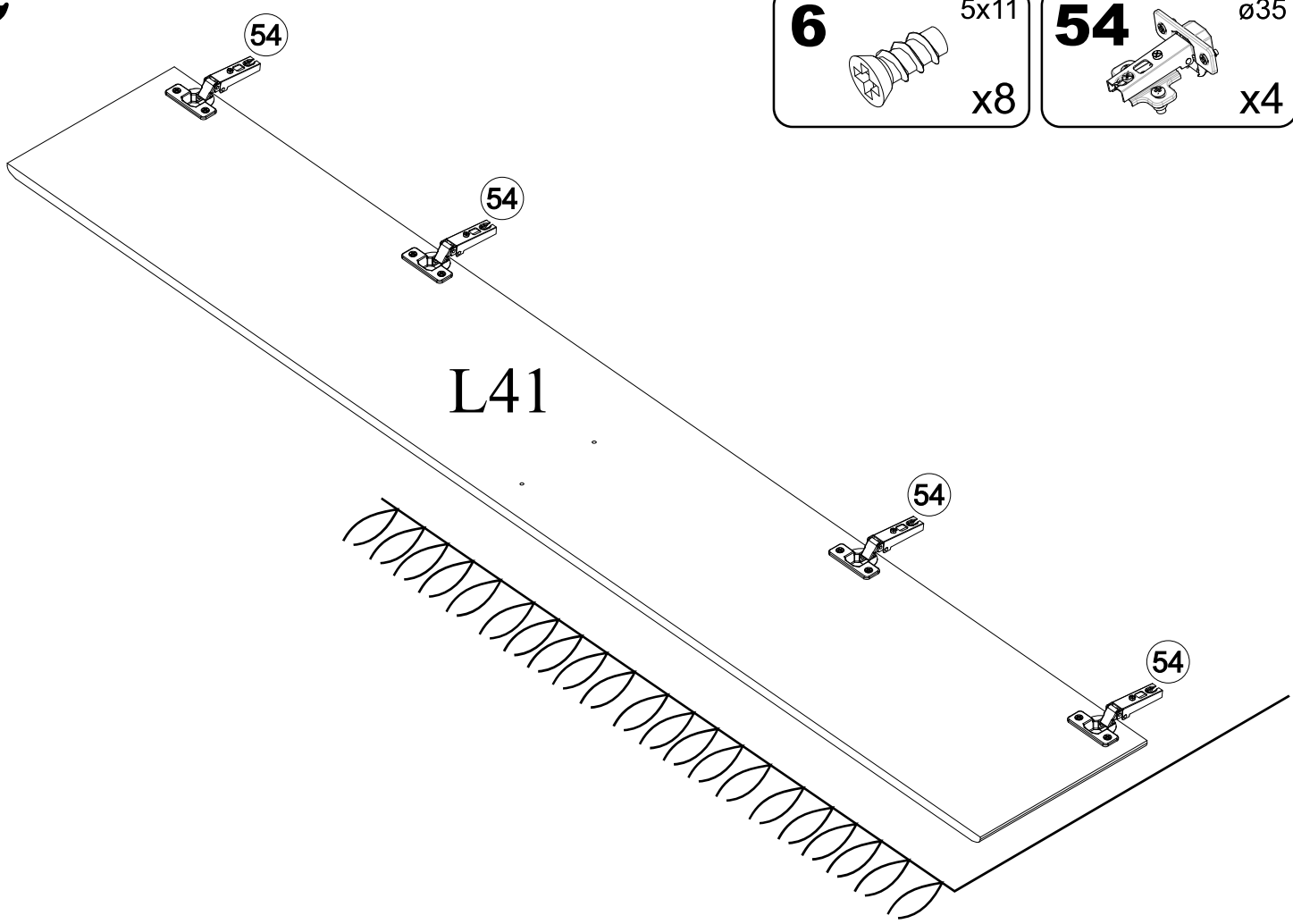

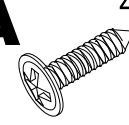

8

4A 4x16
x6

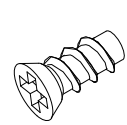

6 5x11
x8



36 x6



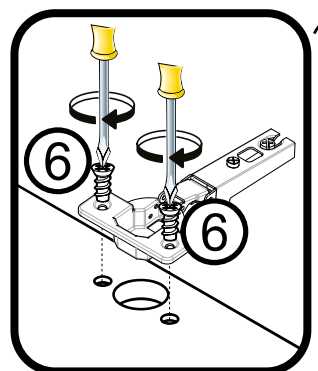
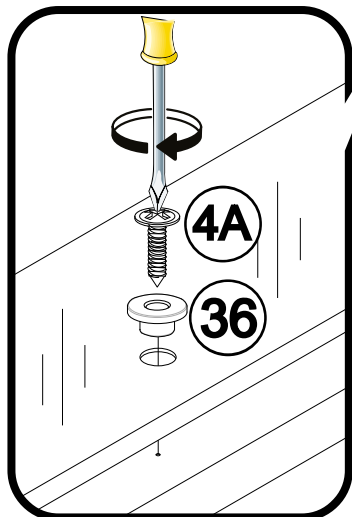
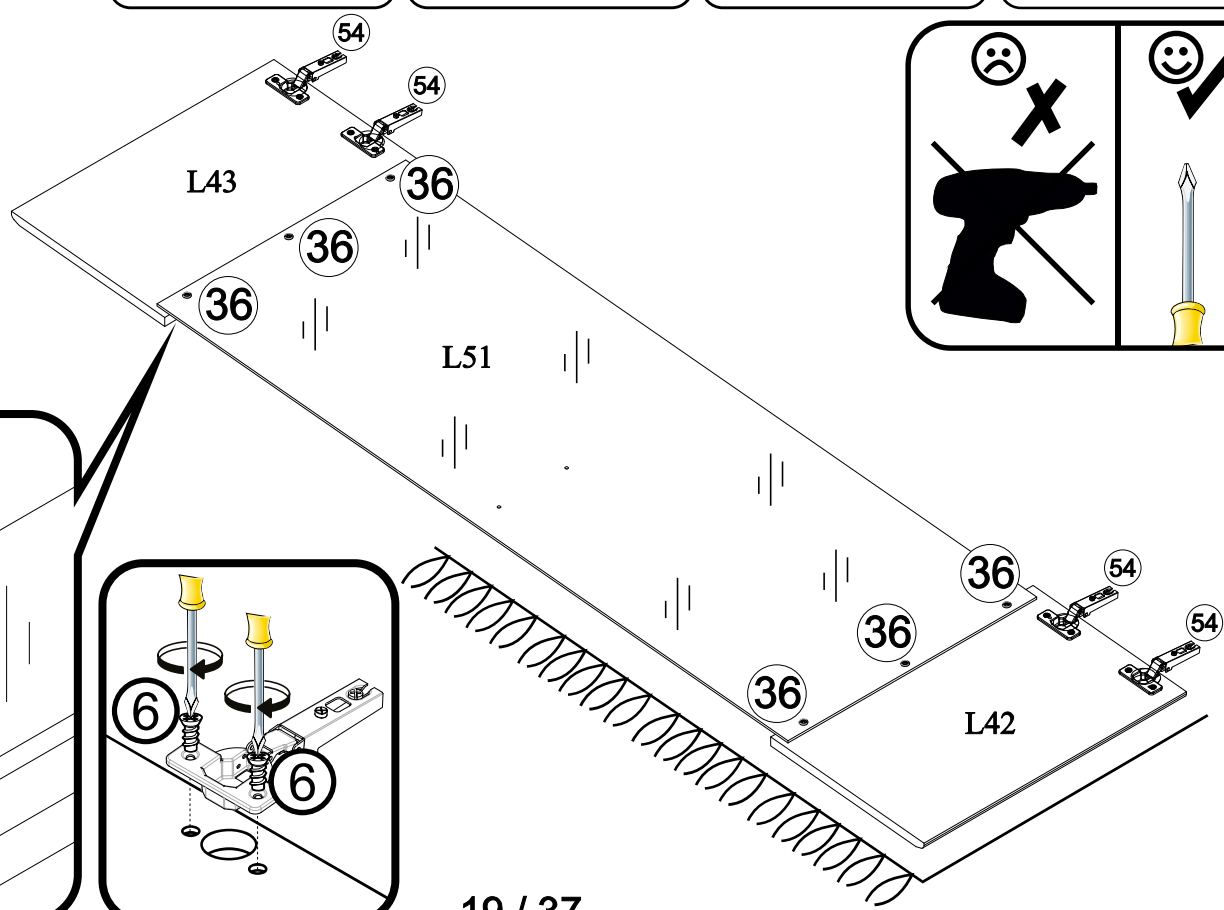

54 ø35
x4



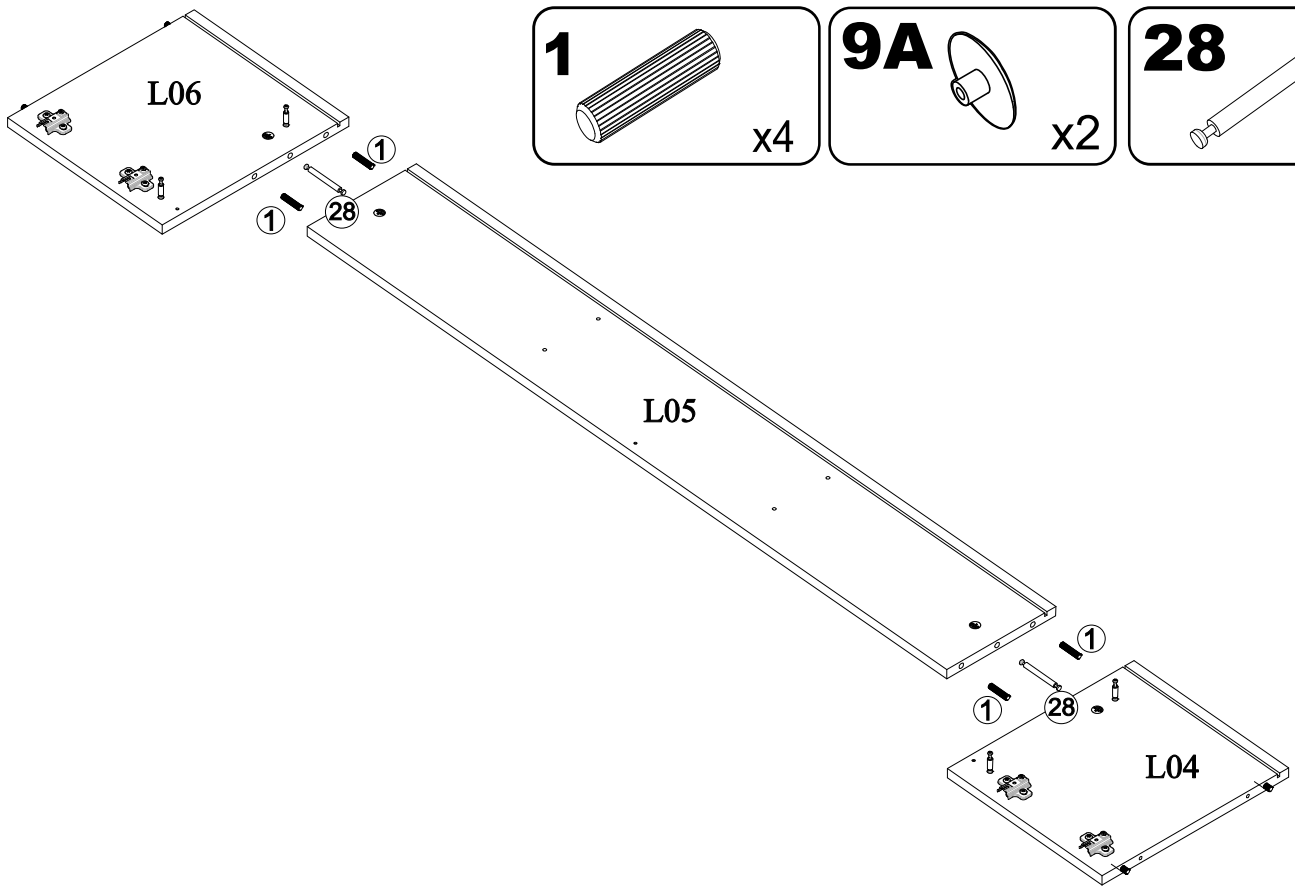

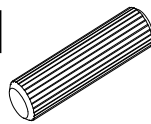
9

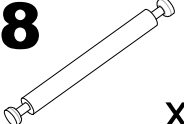

1  x4

9A  x2

28  x2

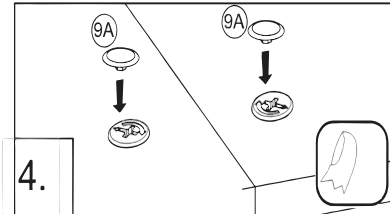
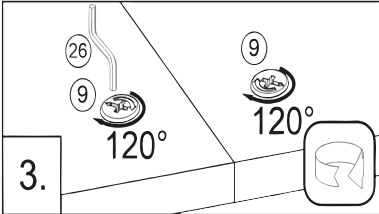
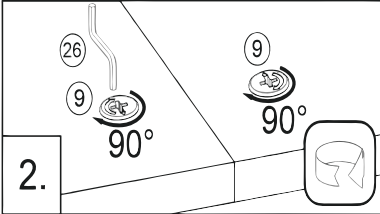
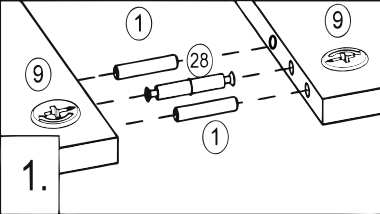

10

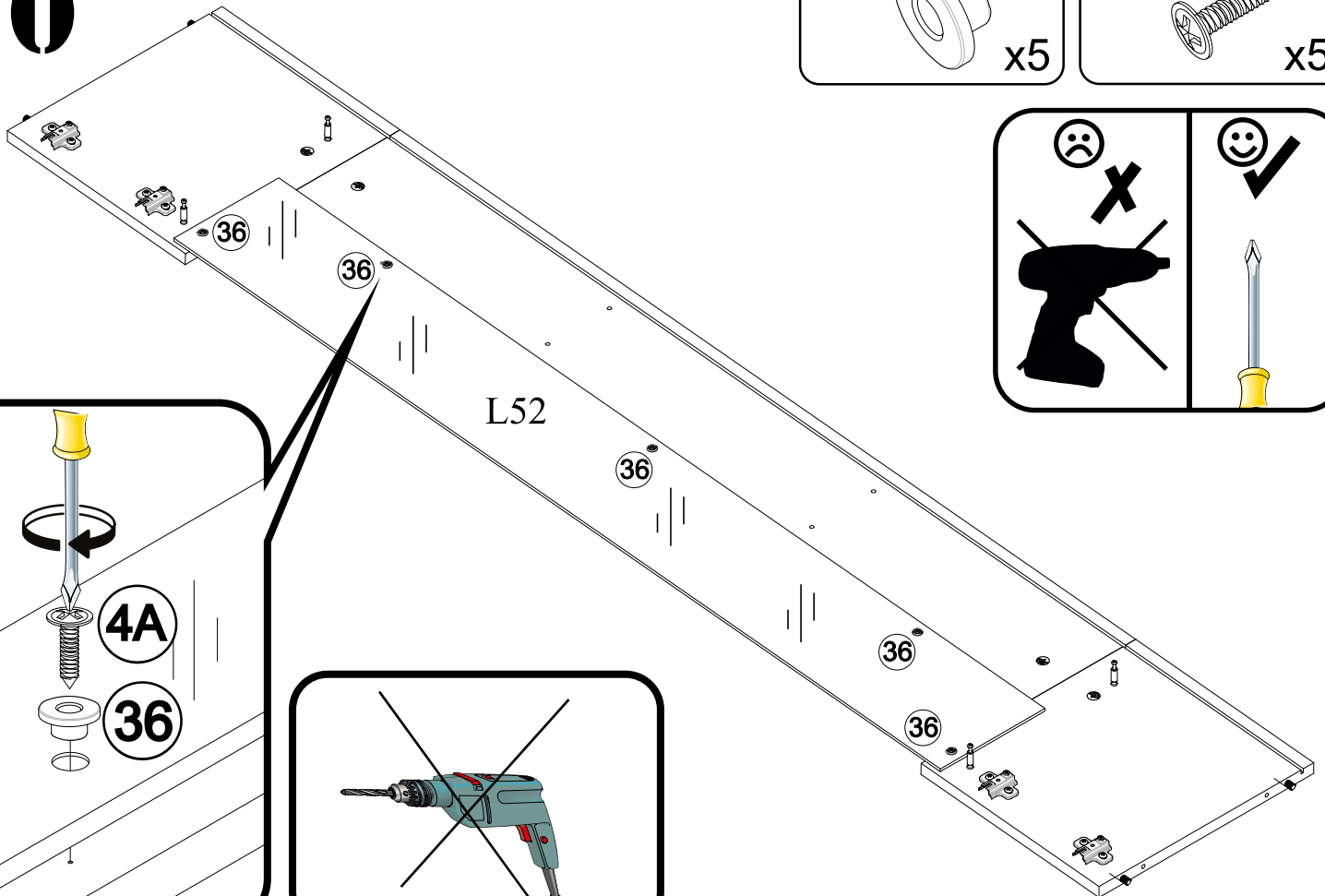

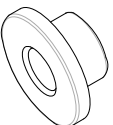
36  x5

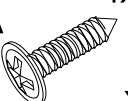
4A  4x16 x5

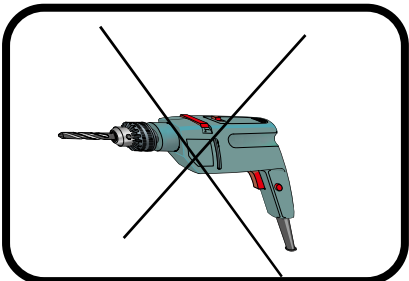
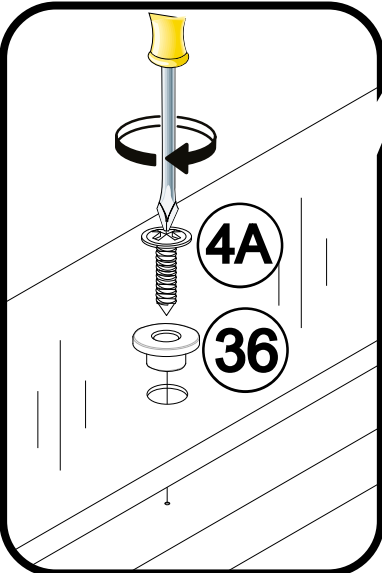
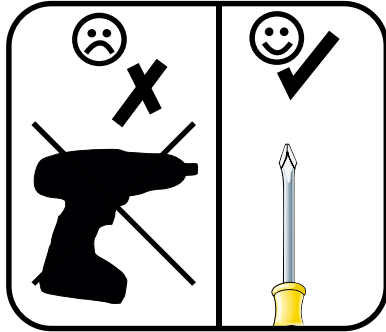

11

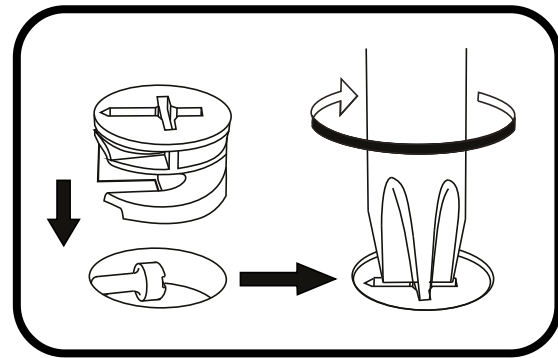
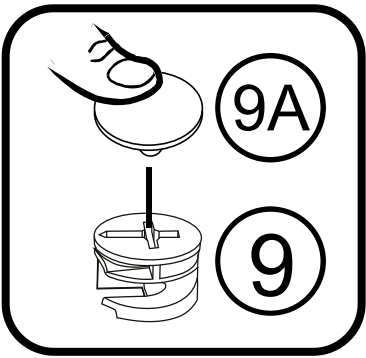
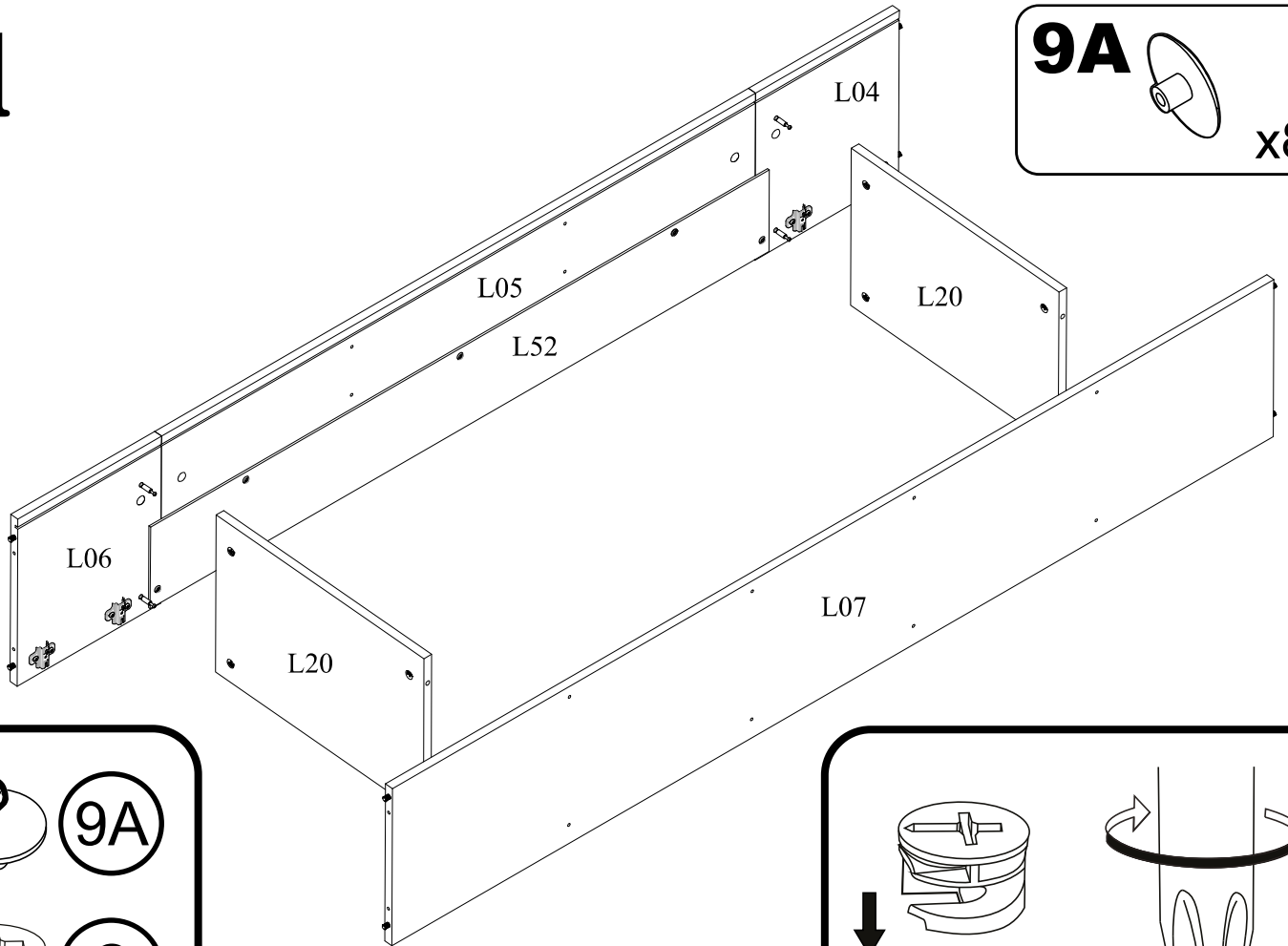

12

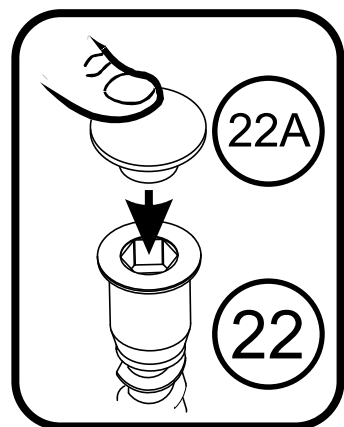
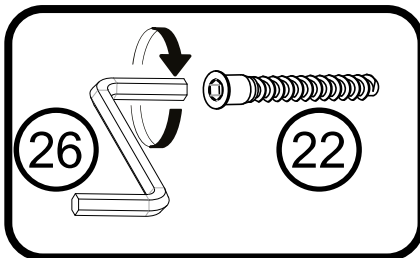
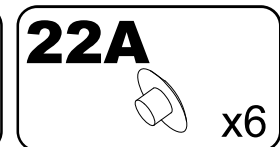
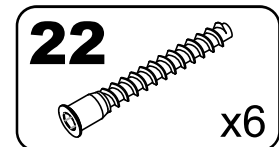
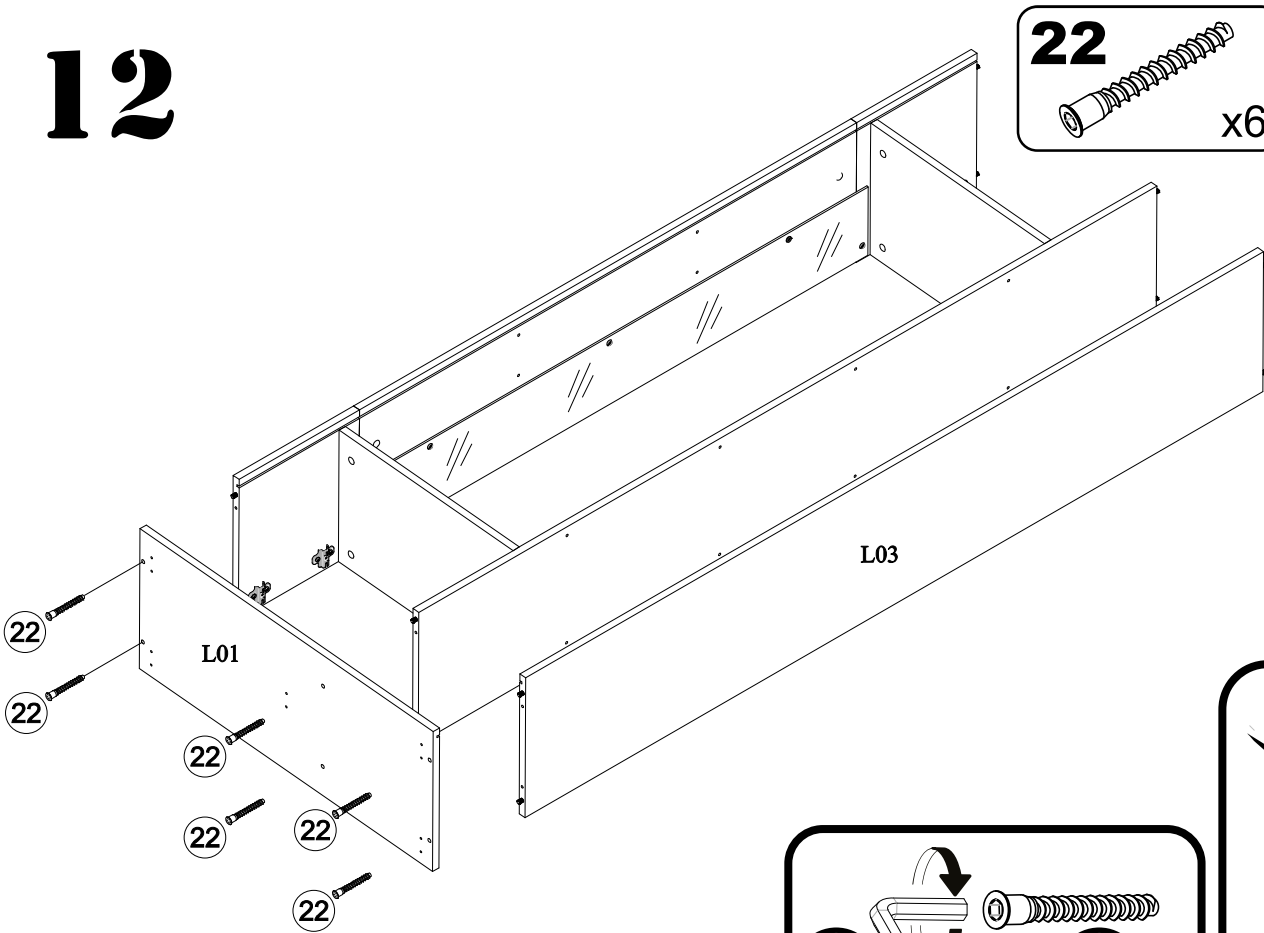

15

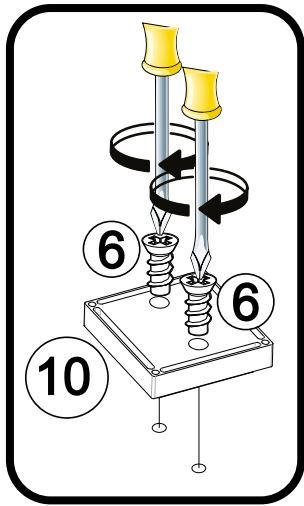
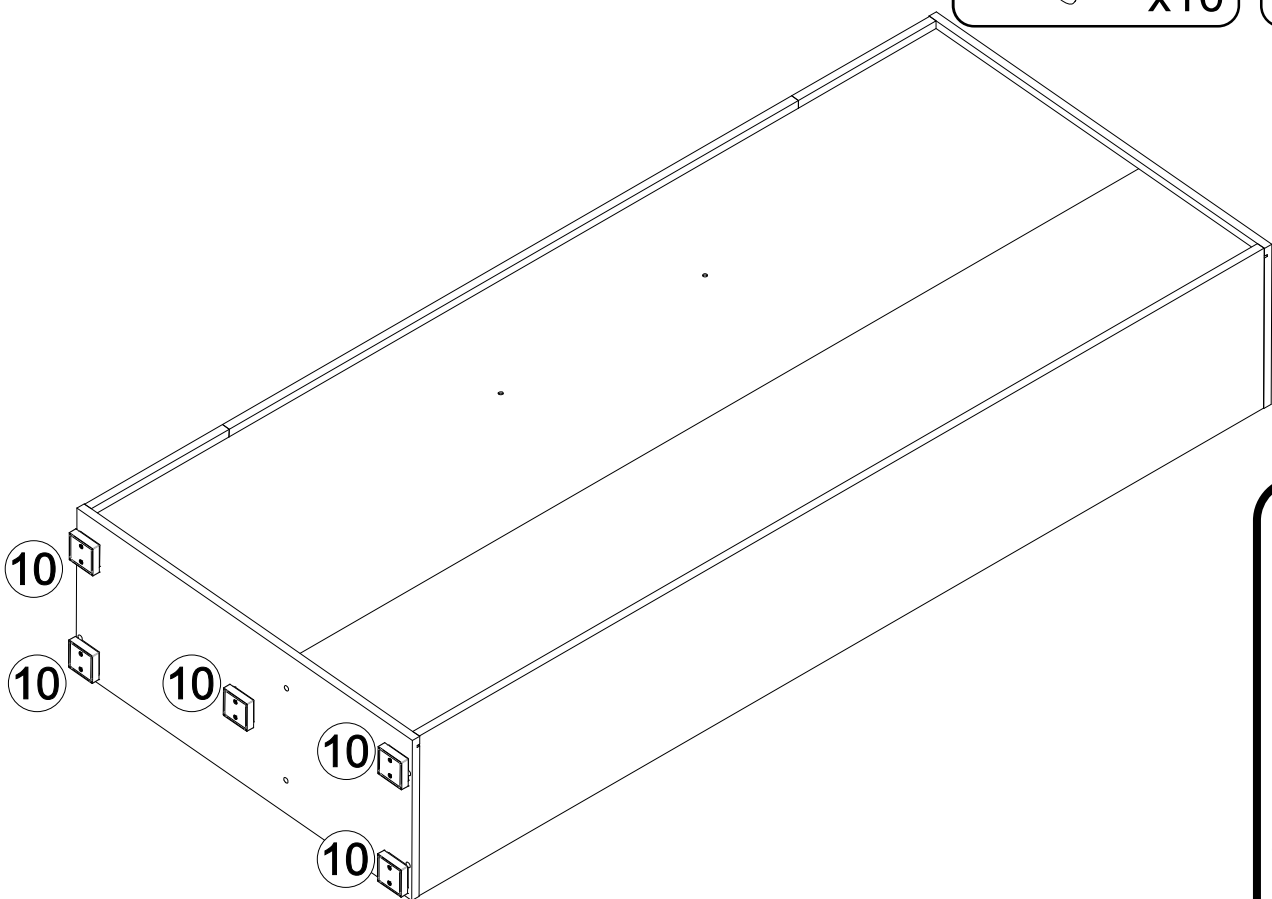
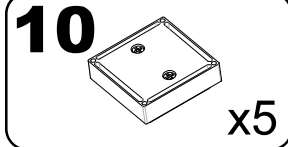
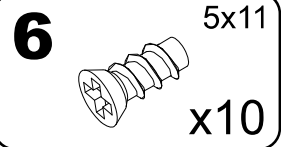

16

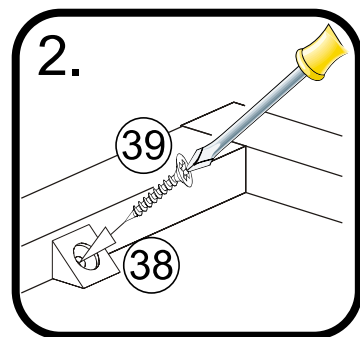
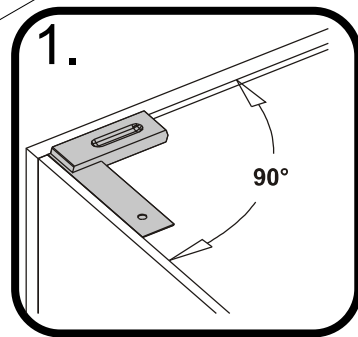
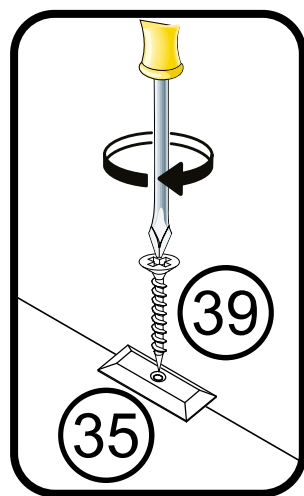
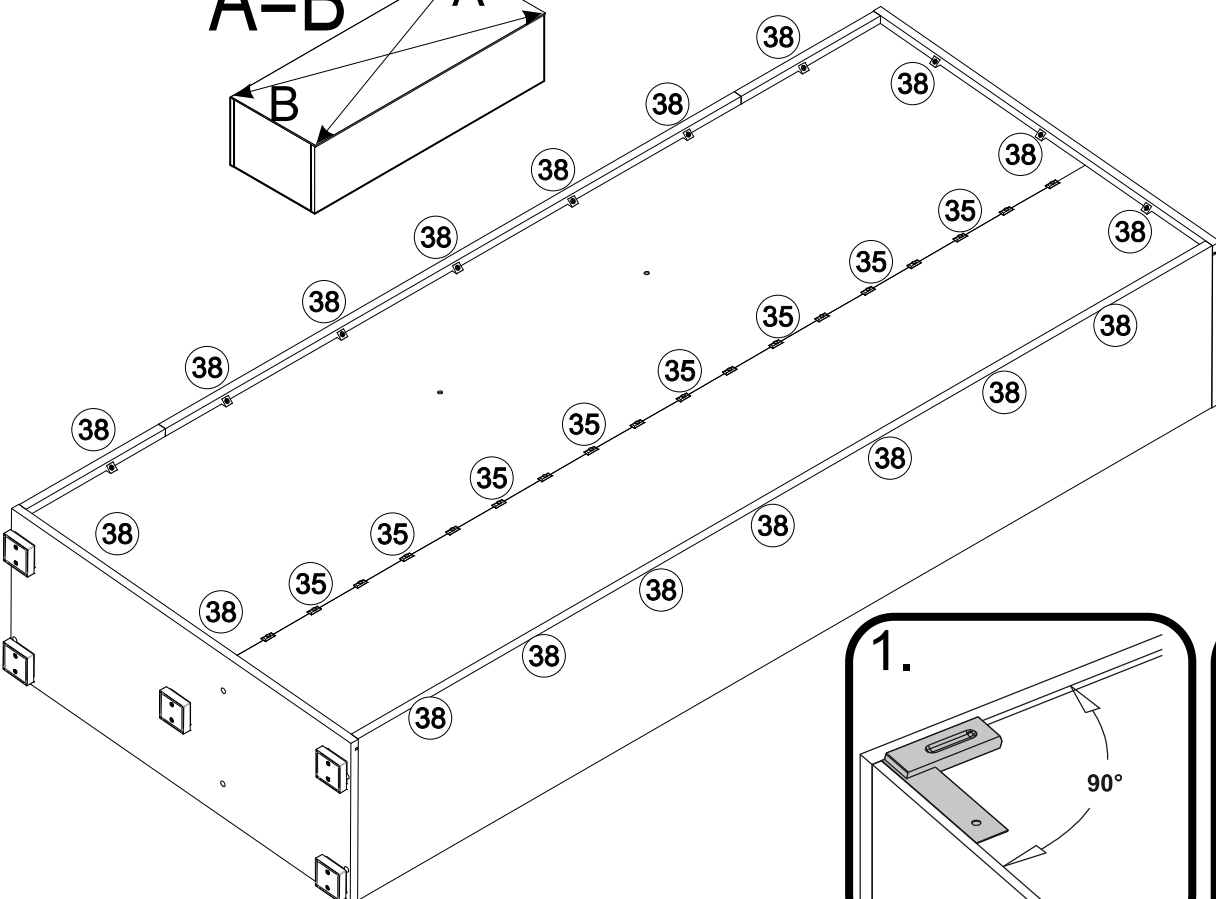
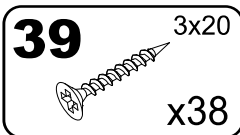
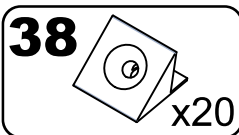
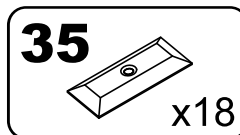
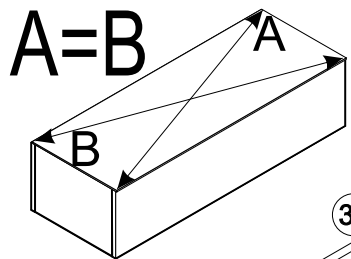

17

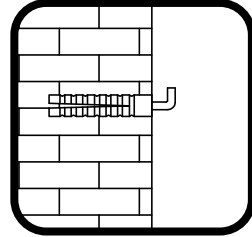
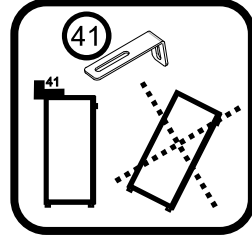
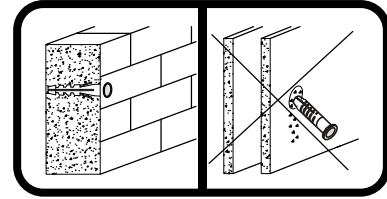
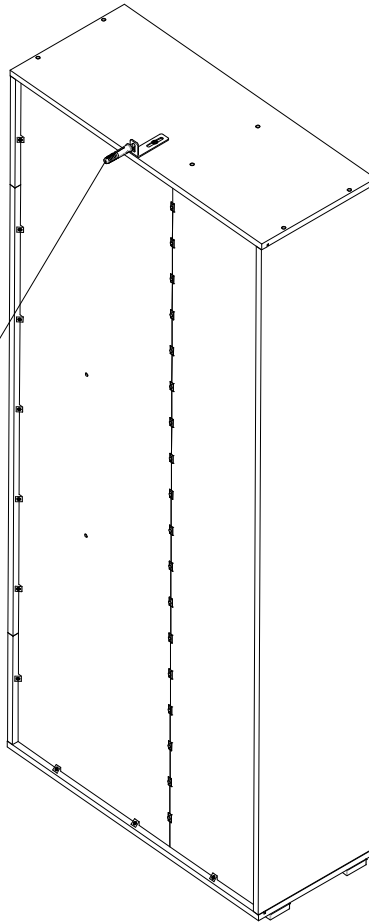
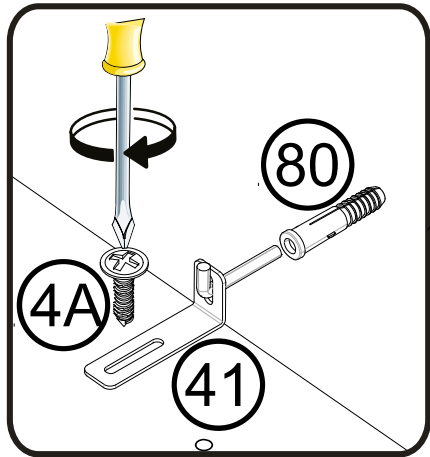
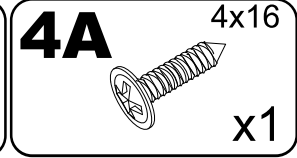
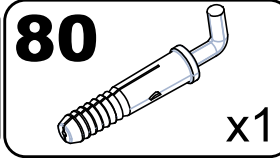
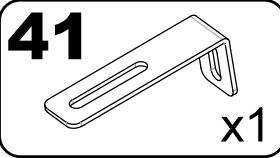

18

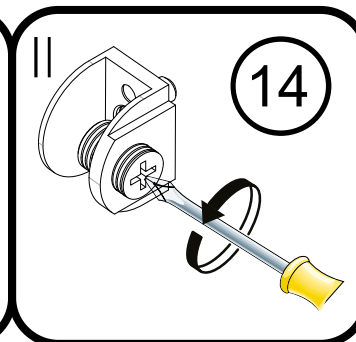
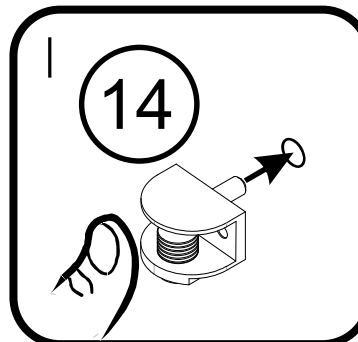
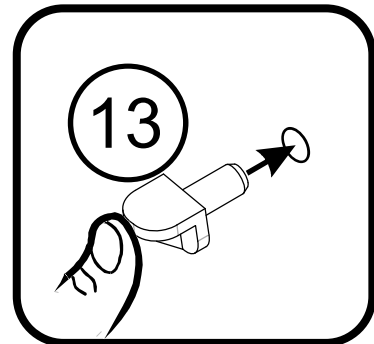
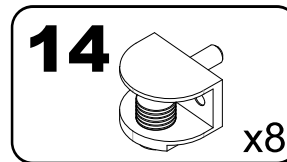
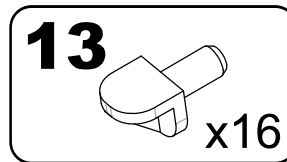
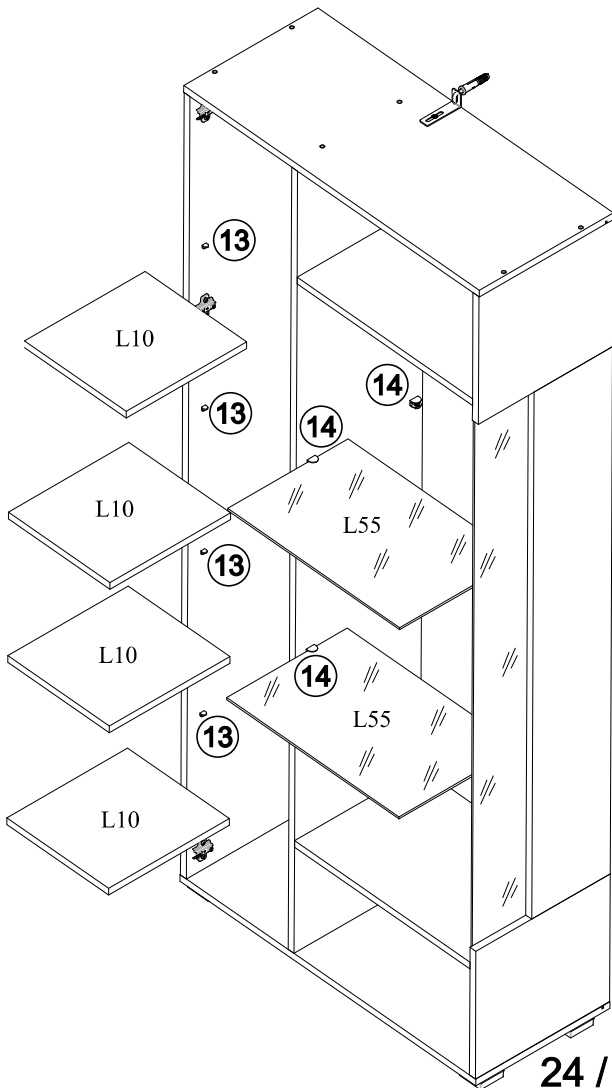

19

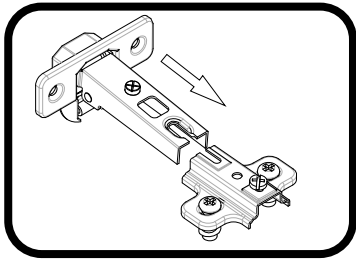

54

54

54

54

4

4

54

4A

36

4A

36

3

54

54

54

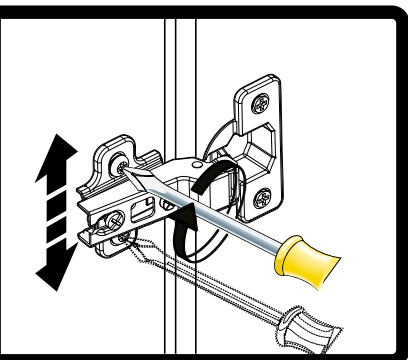
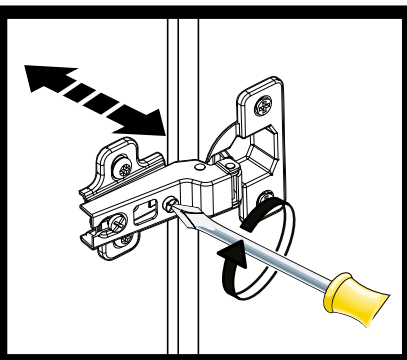
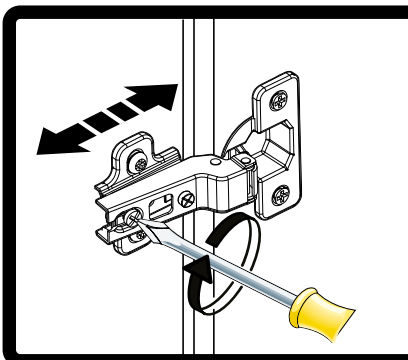
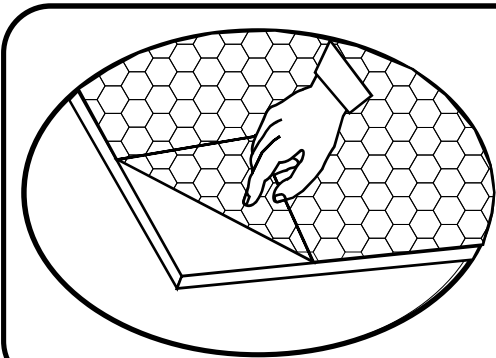
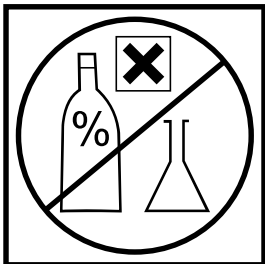
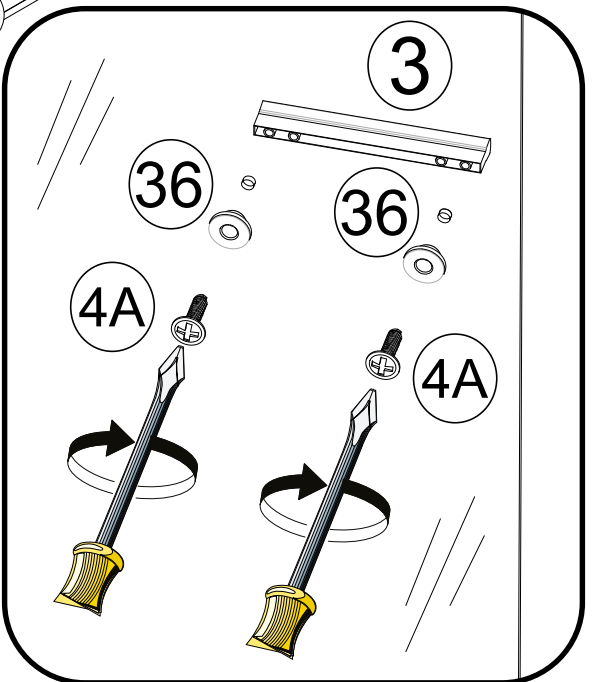
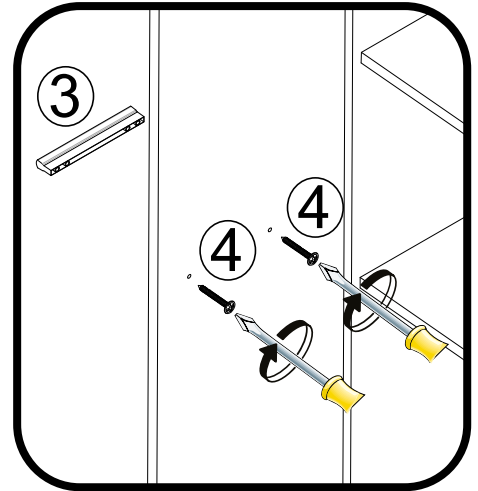
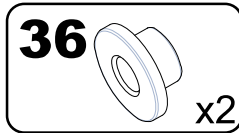
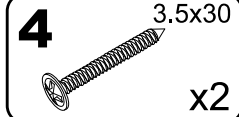
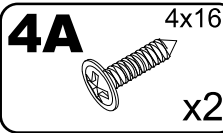
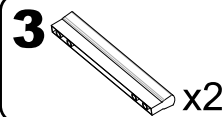

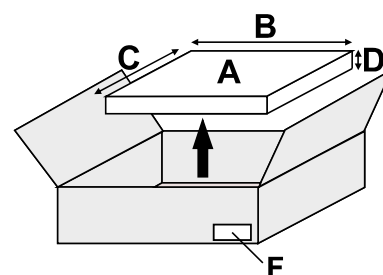
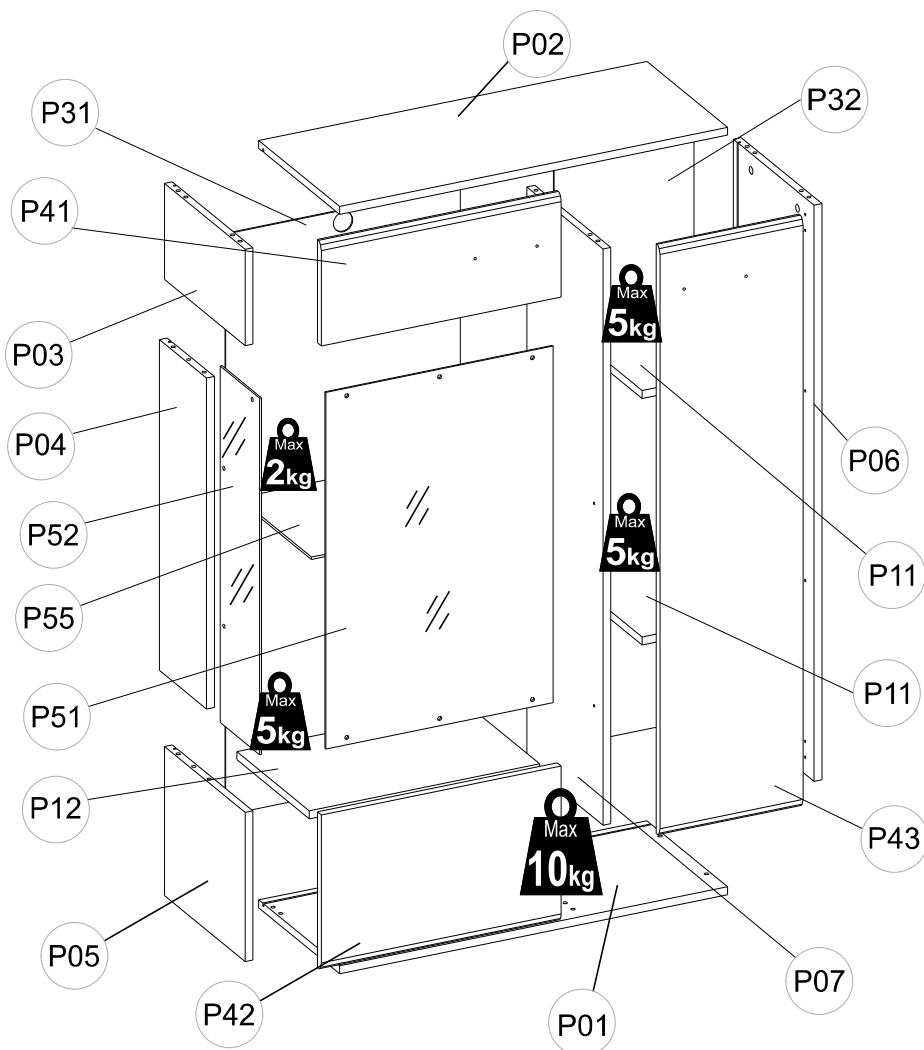
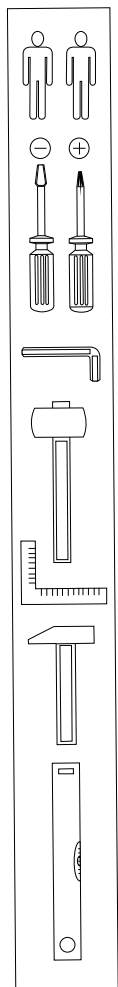
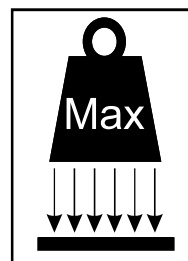

A	B_(mm)	C_(mm)	D_(mm)	E	F
P01	802	334	16	1	1 5
P02	802	334	16	1	1 5
P03	195	334	16	1	1 5
P04	670	195	16	1	1 5
P05	302	334	16	1	1 5
P06	1167	334	16	1	1 5
P07	1167	314	16	1	1 5
P11	276	300	16	2	1 5
P12	476	300	16	1	2 5
P31	1177	485	3	1	2 5
P32	1177	289	3	1	1 5
P41	209	496	16	1	2 5
P42	316	496	16	1	2 5
P43	1195	296	16	1	1 5
P51	722	470	4	1	2 5
P52	722	163	4	1	1 5
P55	467	300	5	1	2 5

1

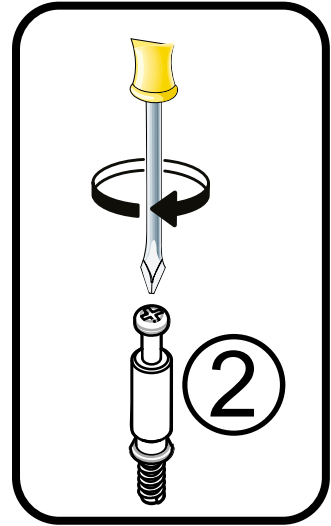
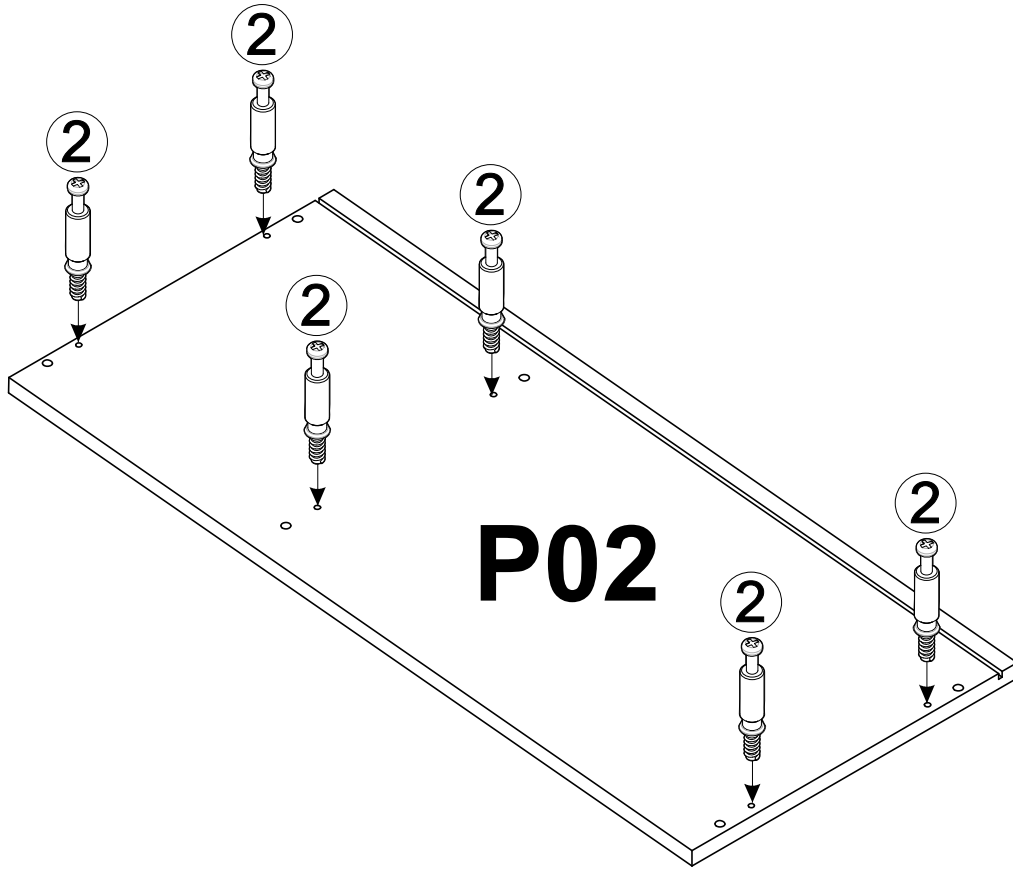
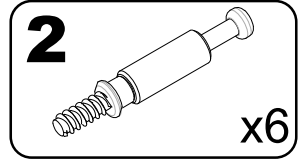

2

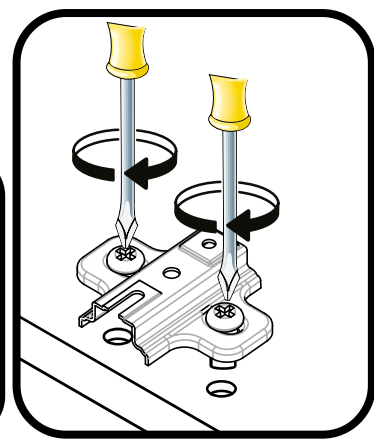
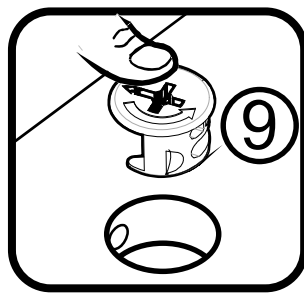
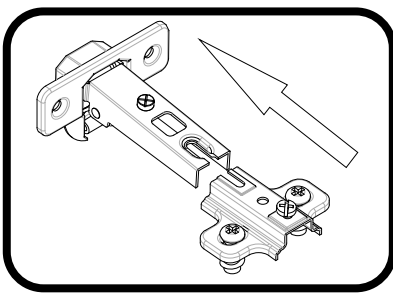
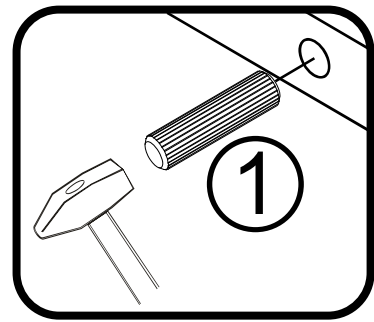
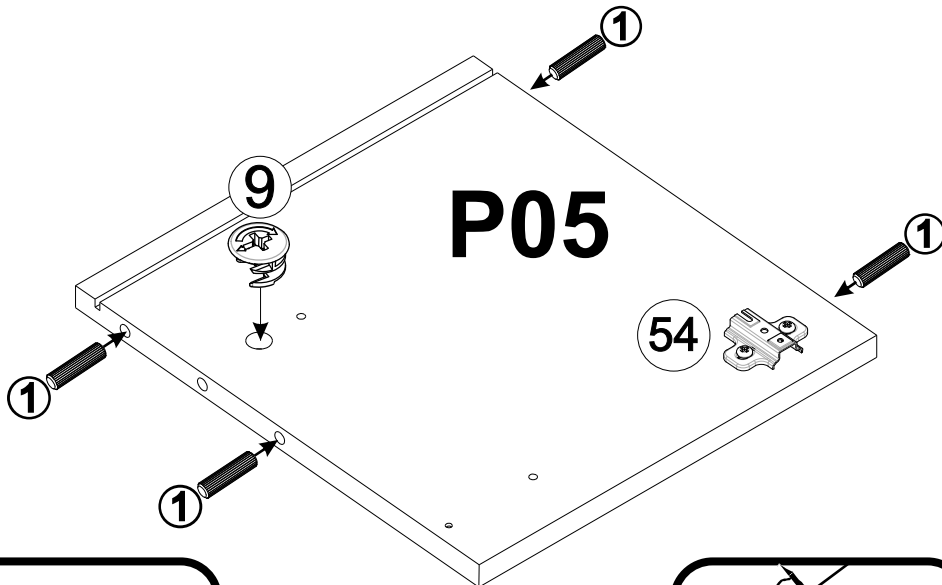
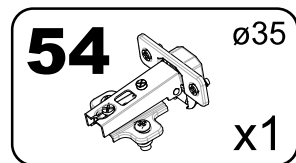
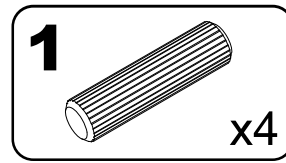
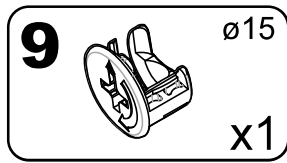

3

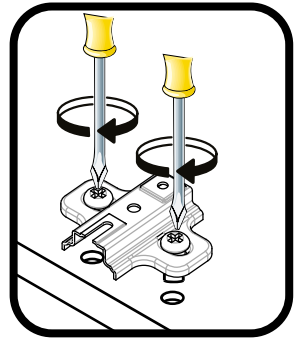
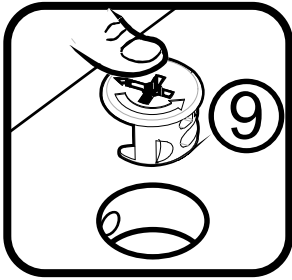
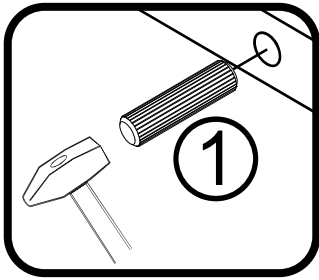
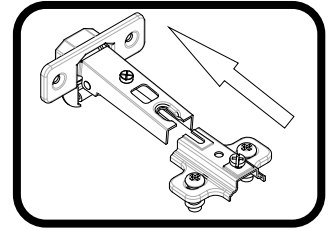
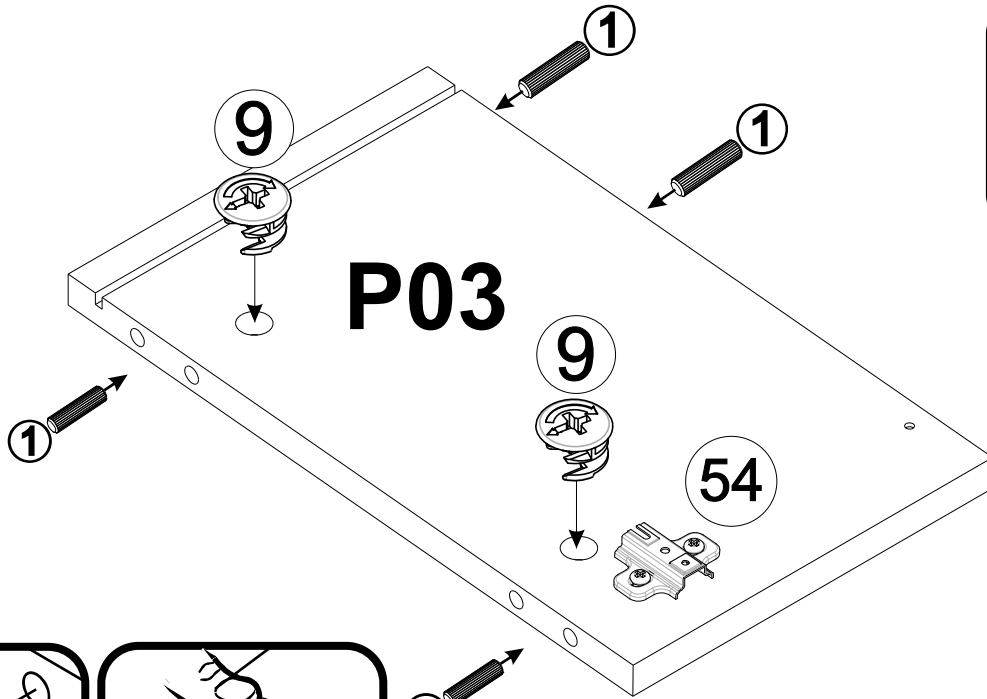
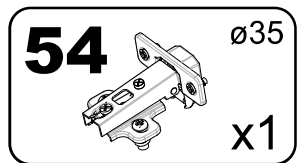
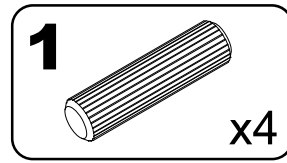
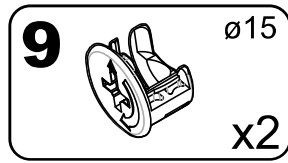

4

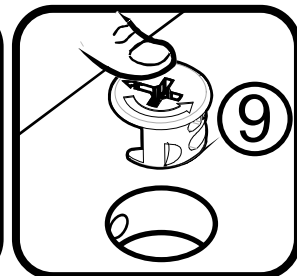
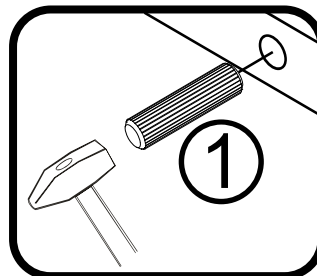
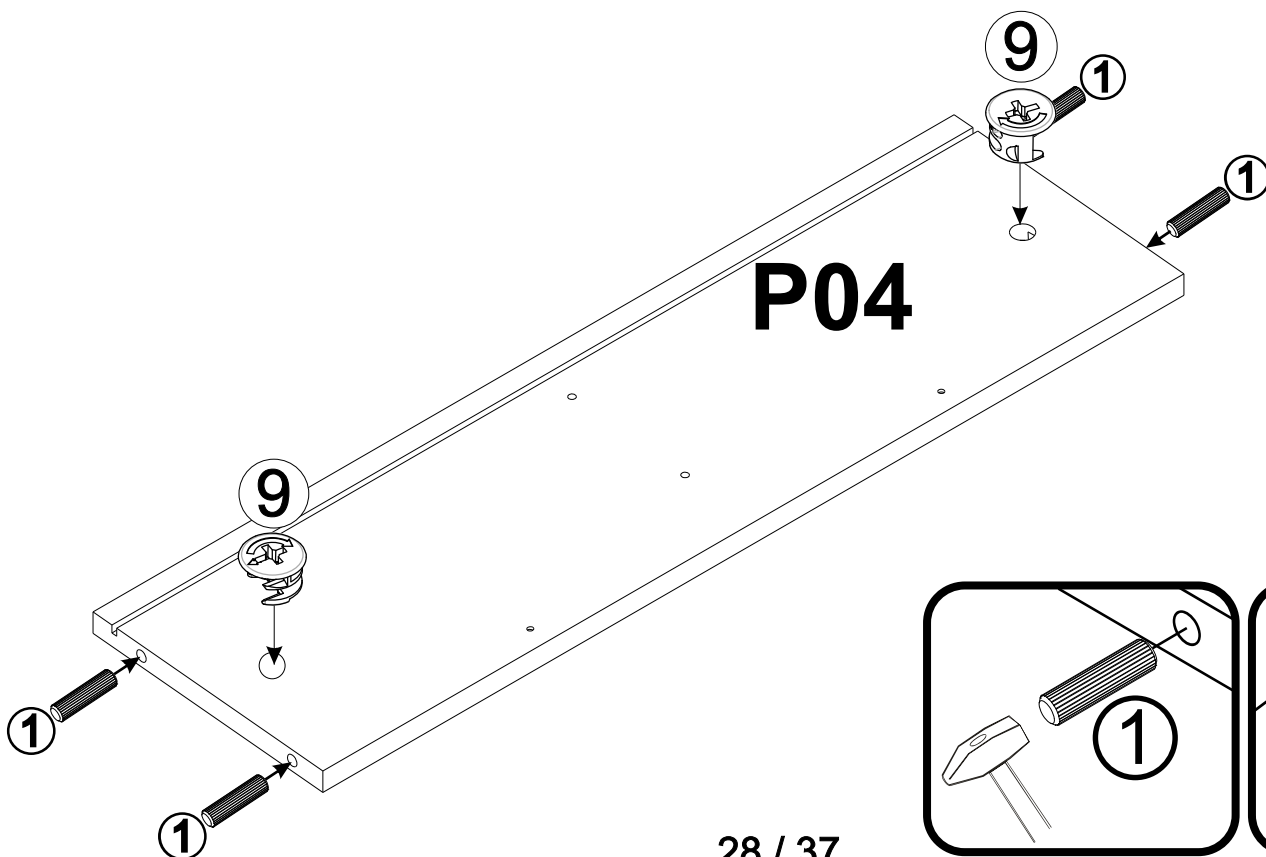
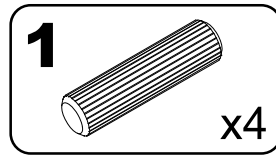
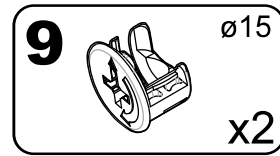

5

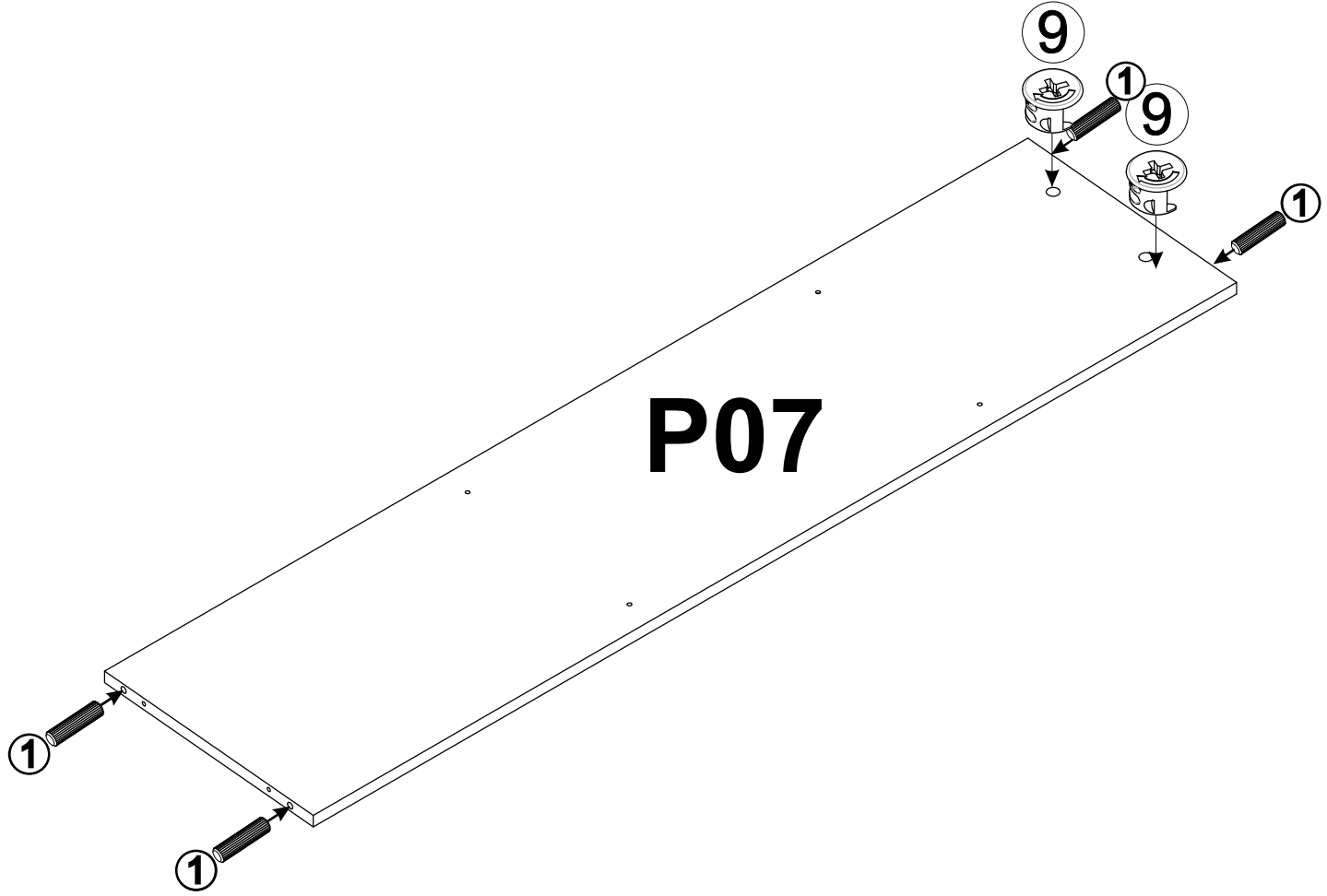
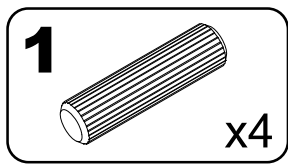
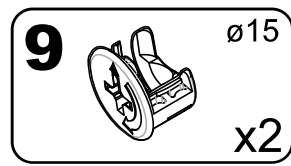

6

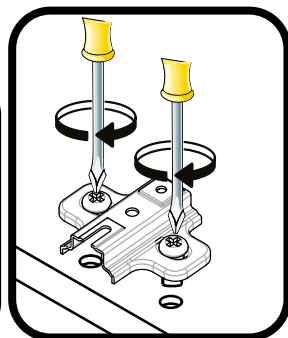
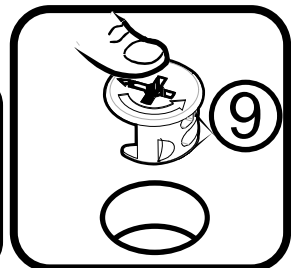
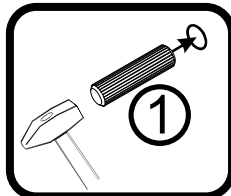
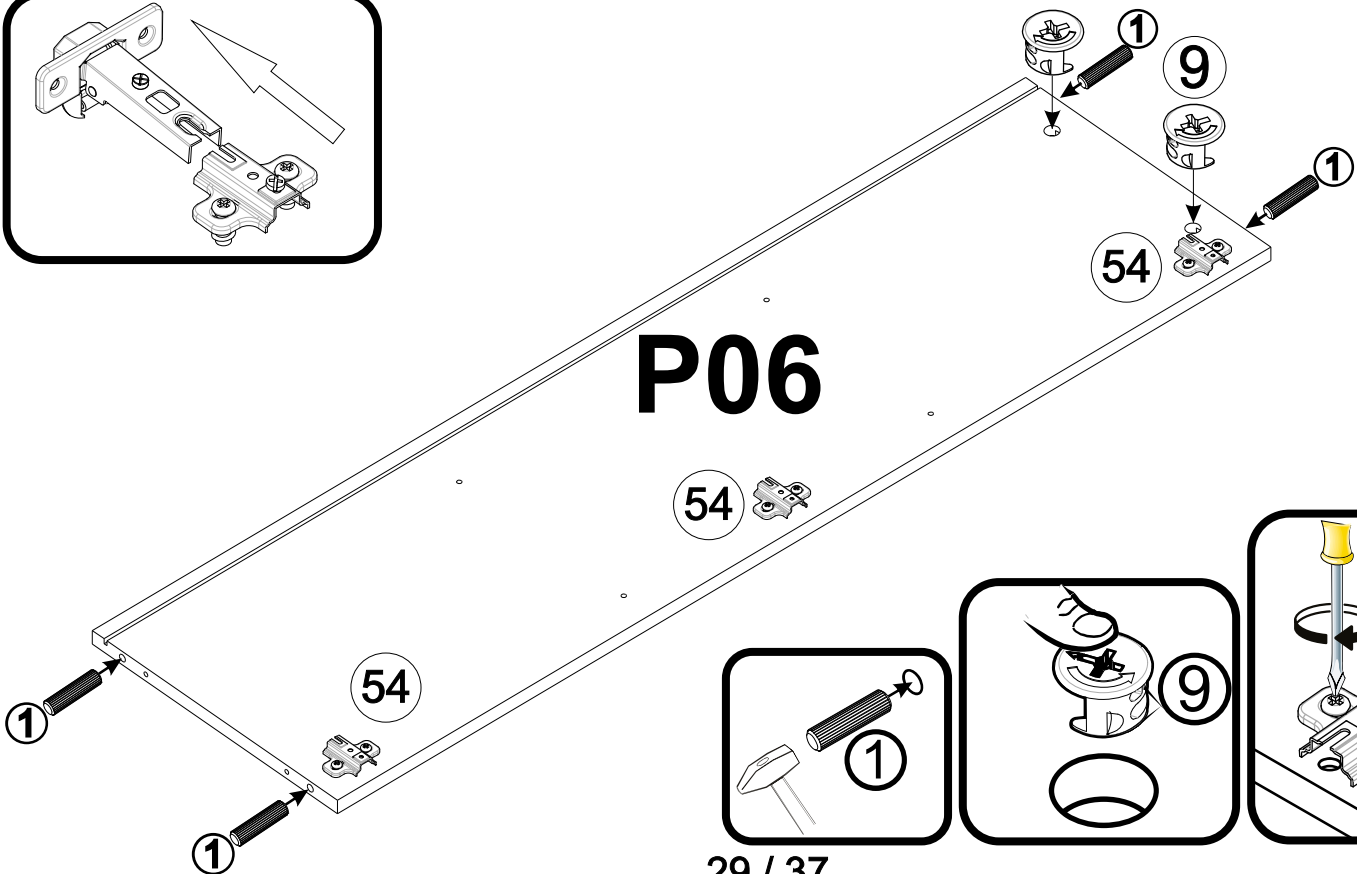
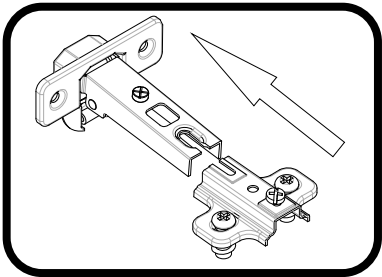
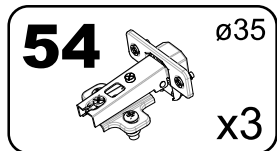
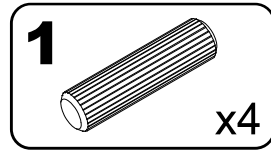
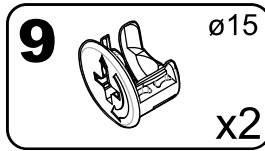

7

4A 4x16
x6

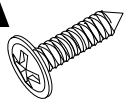

6 5x11
x4

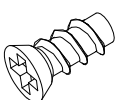

36
x6



54 ø35
x2

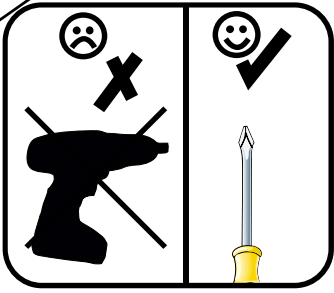
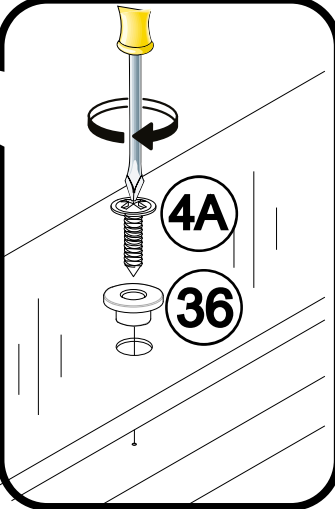
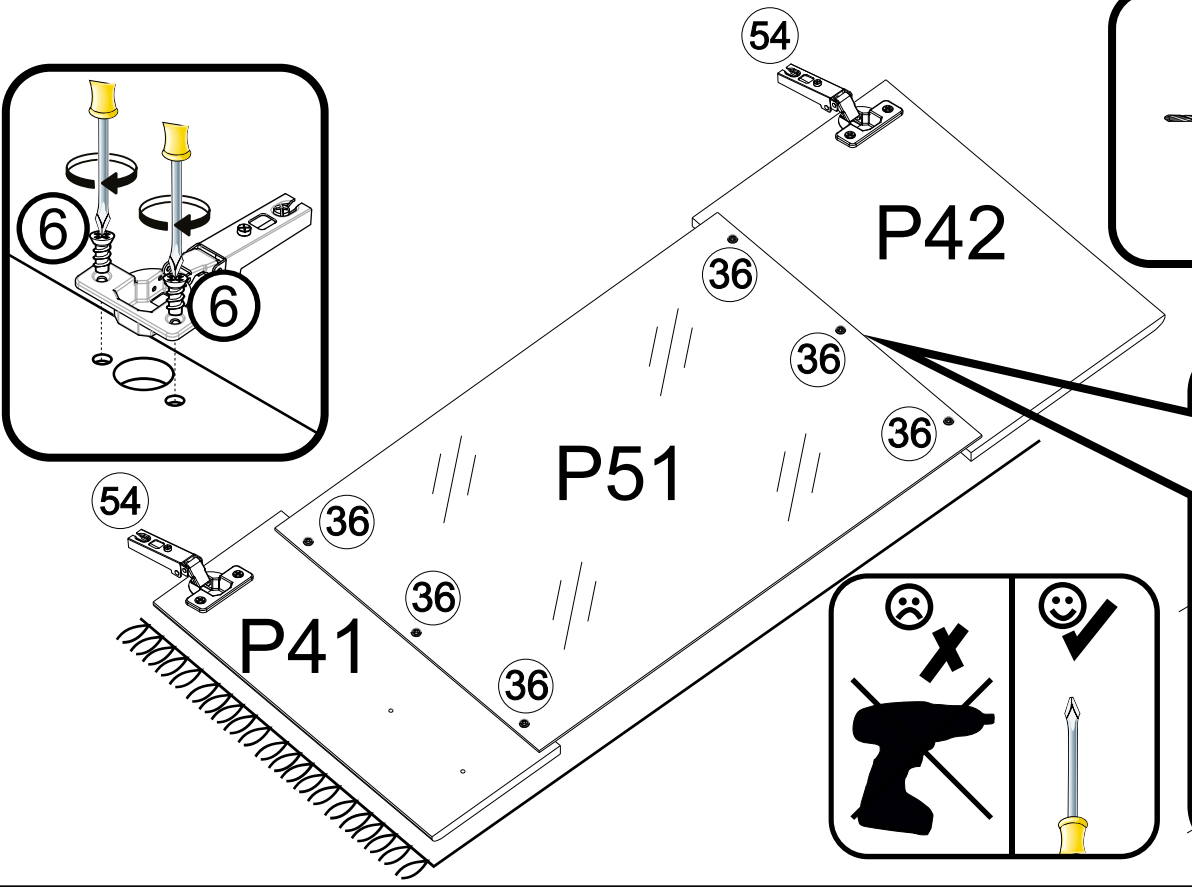
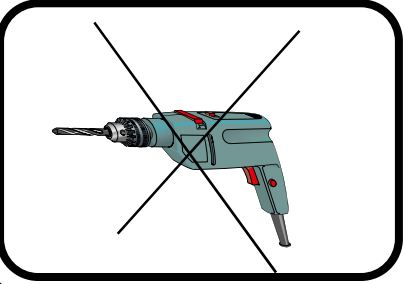
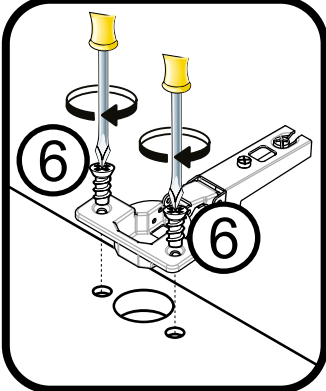
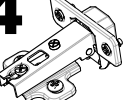

8

54 ø35
x3

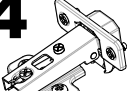

6 5x11
x6

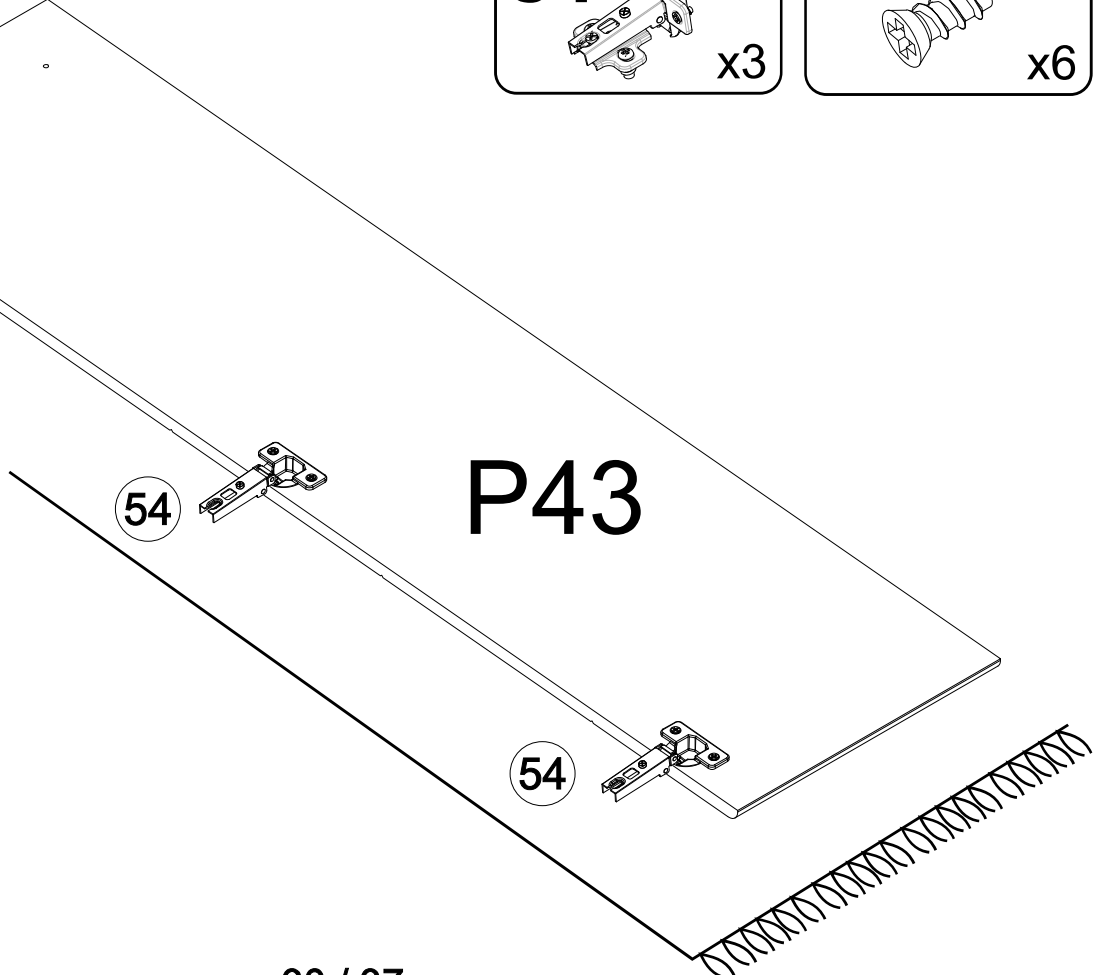
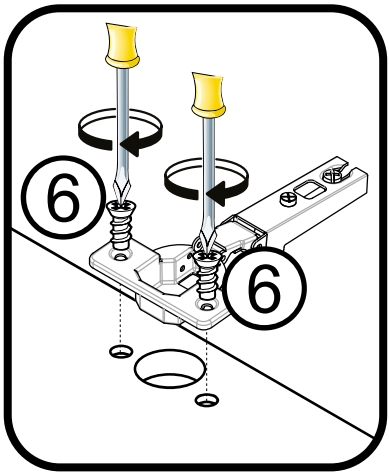
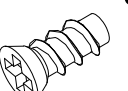

9

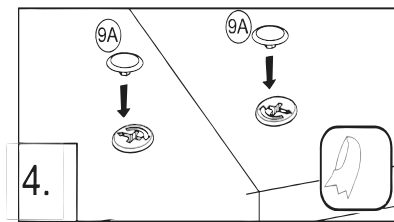
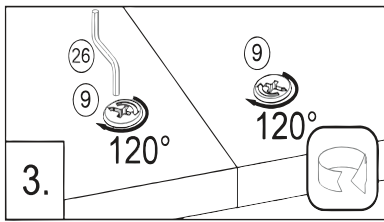
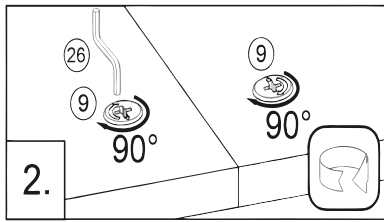
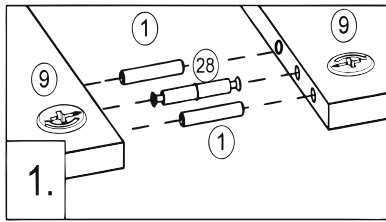
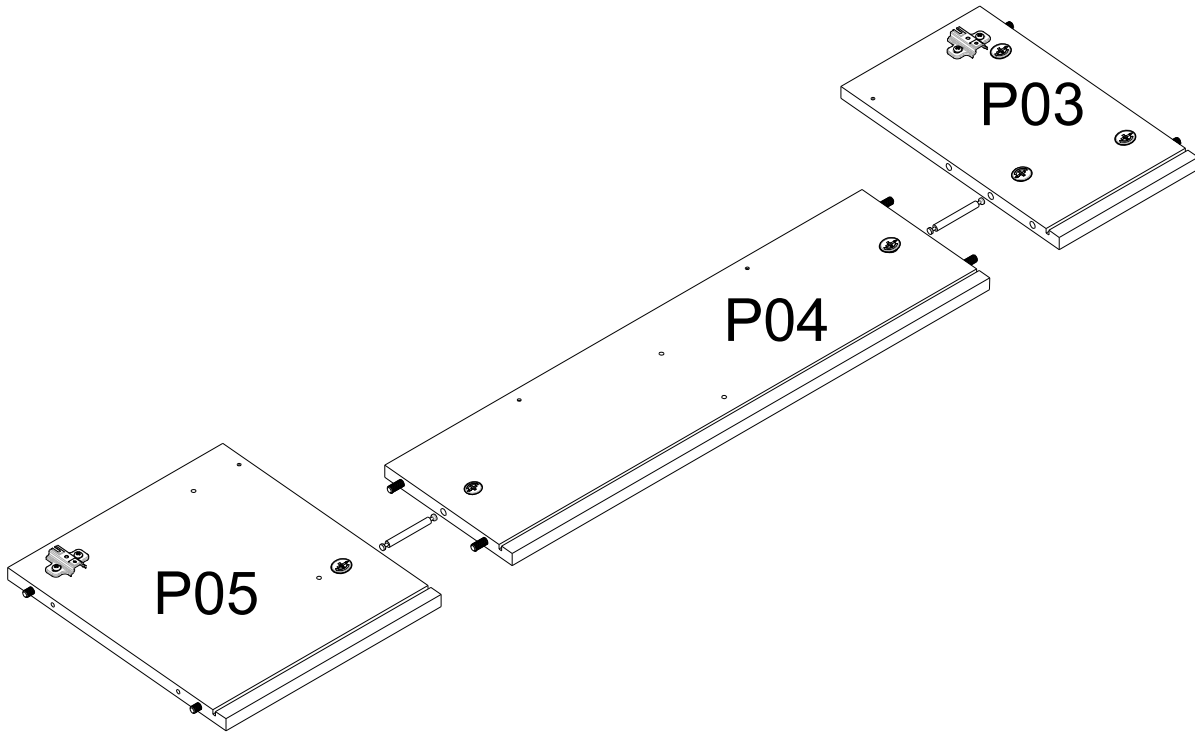
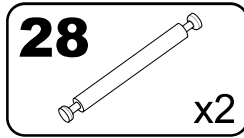
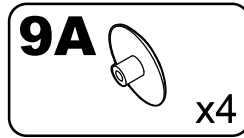

10

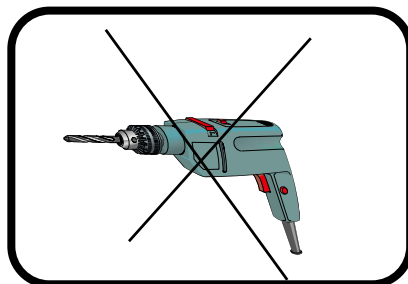
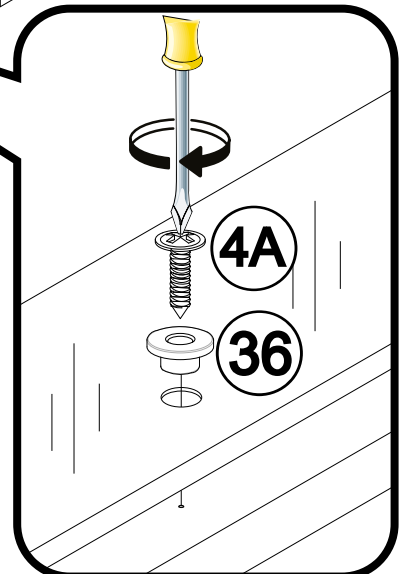
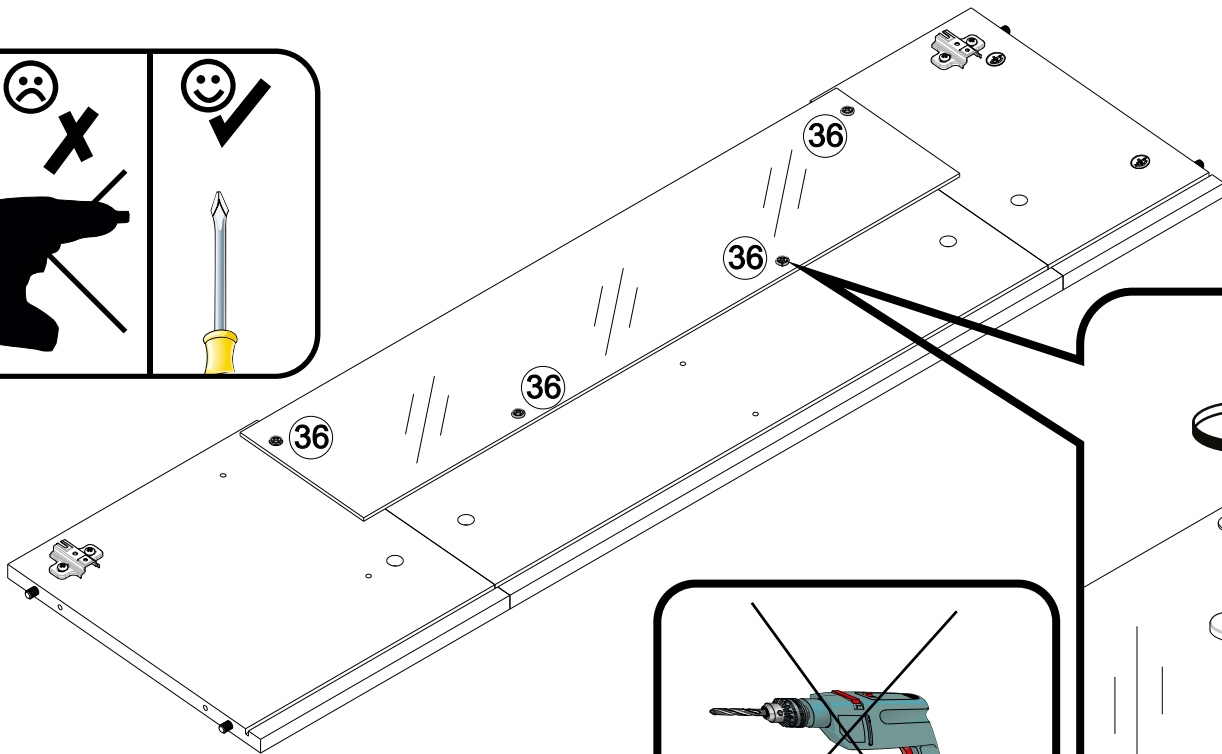
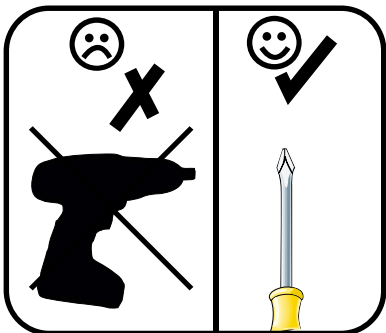
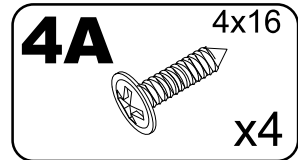
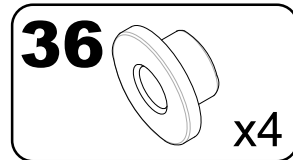

11

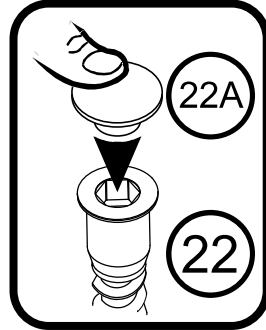
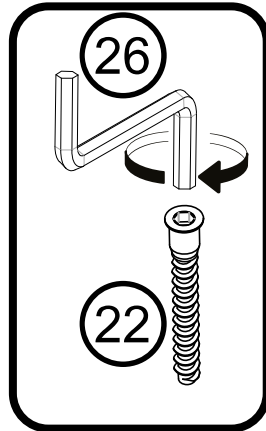
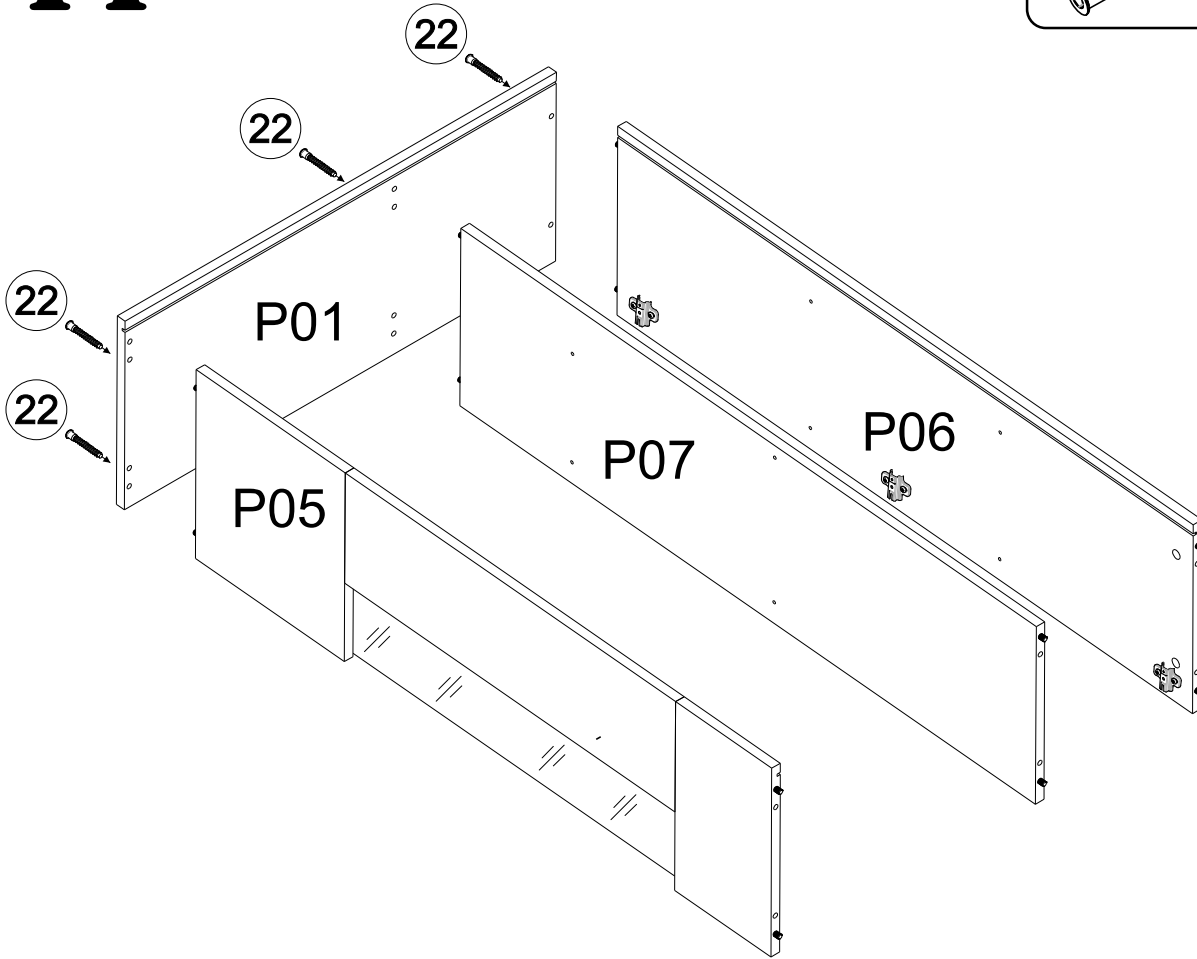
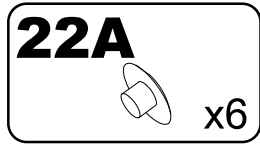
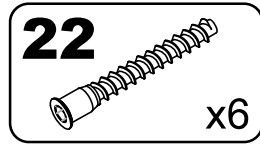

12

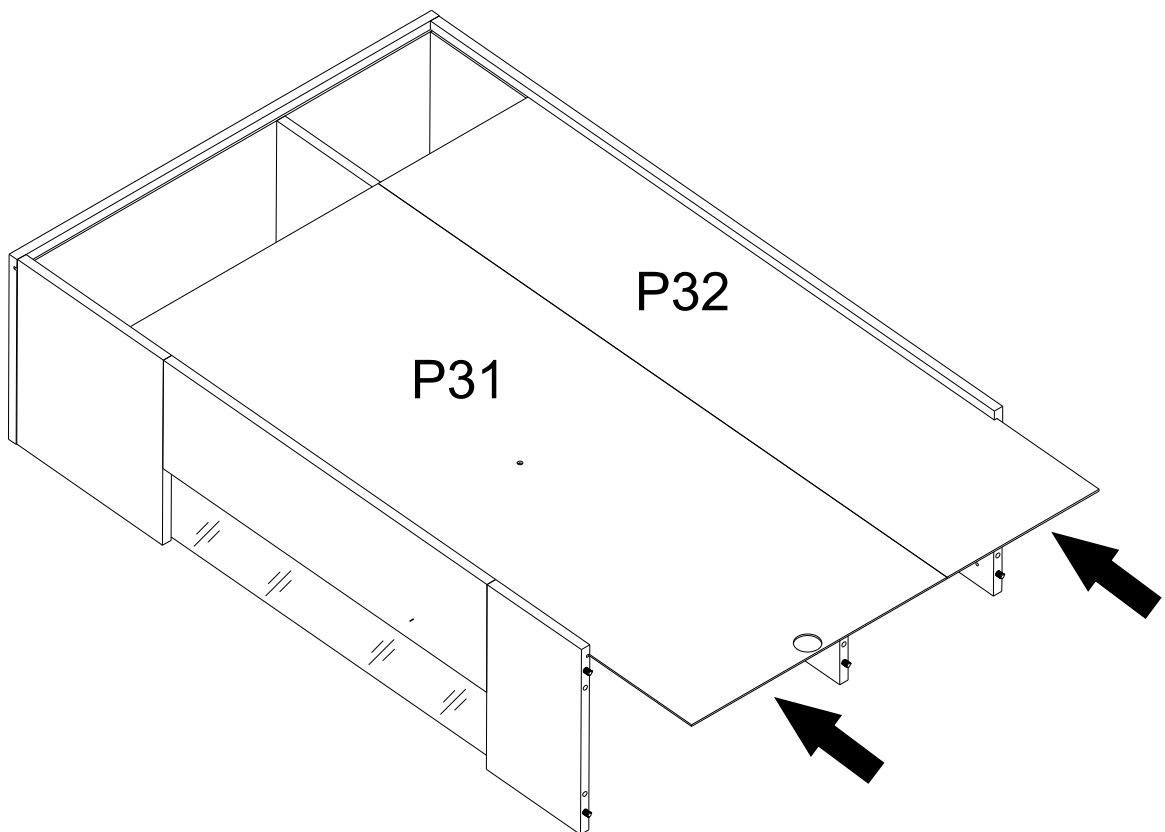

13

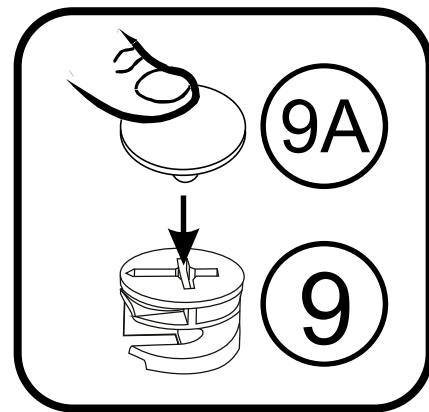
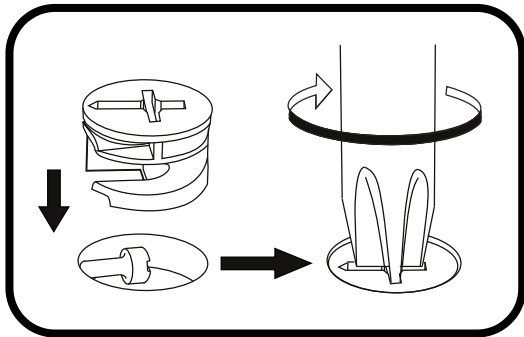
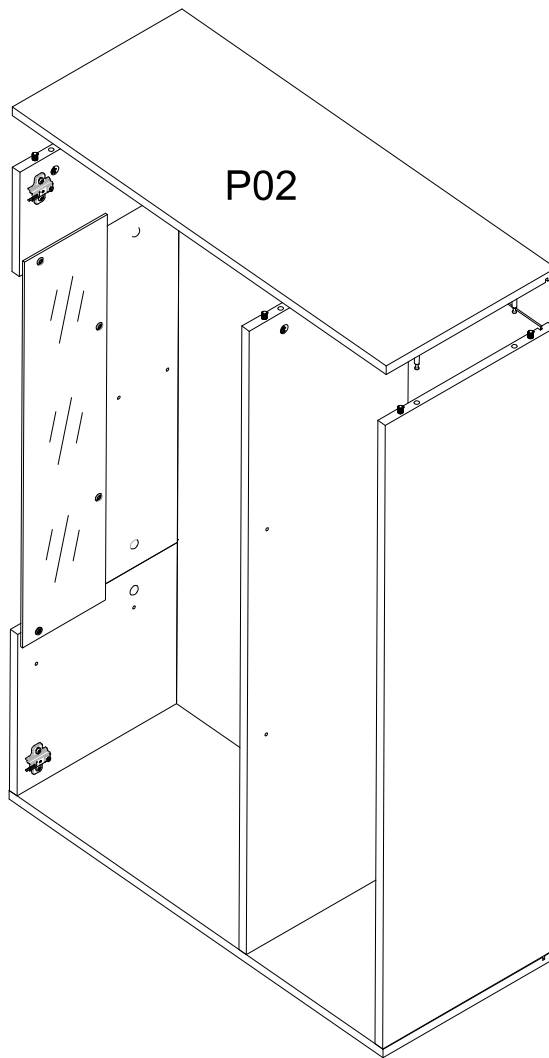
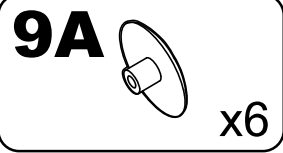

14

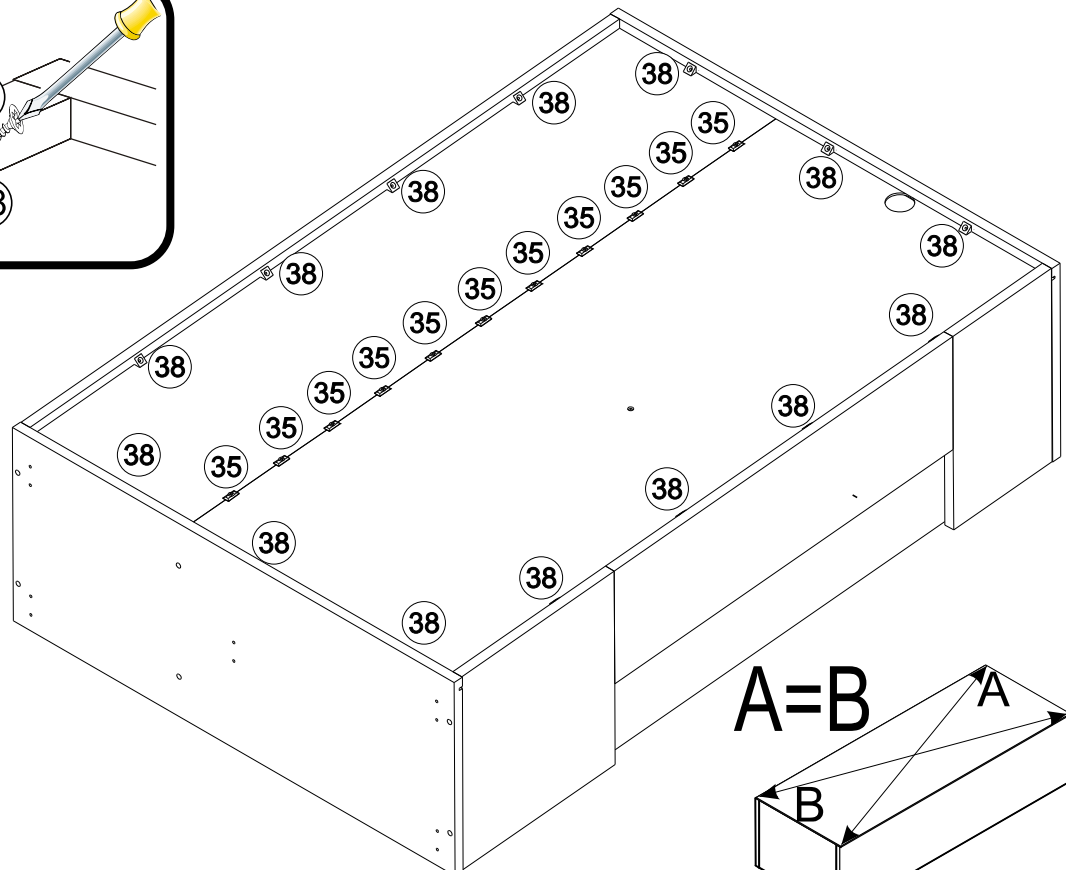
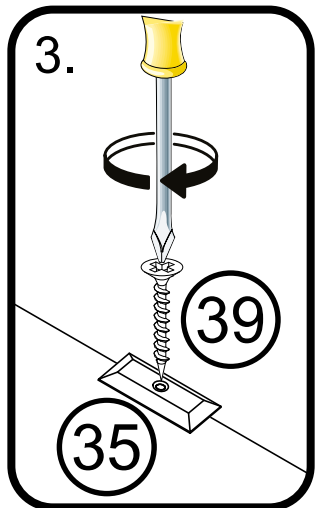
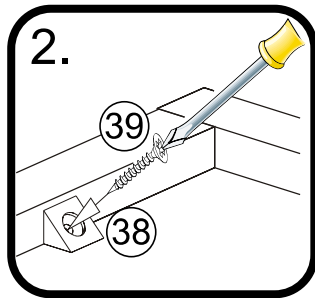
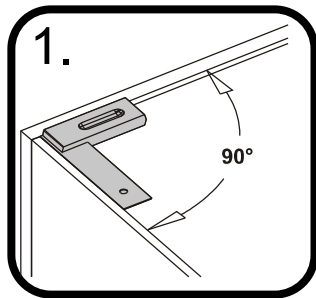
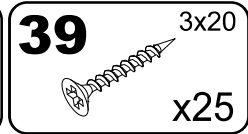
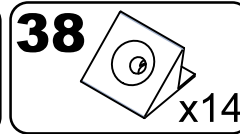
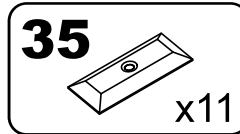

15

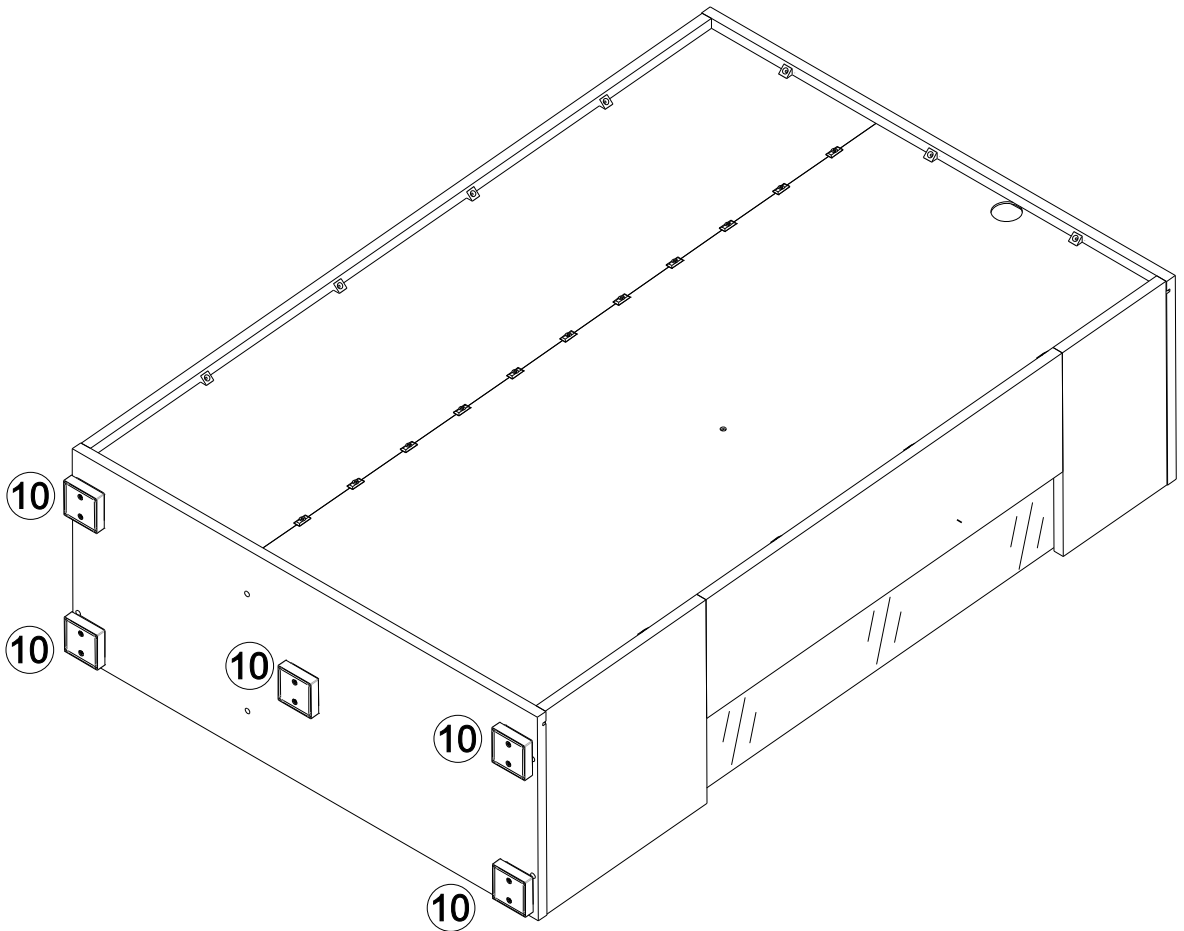
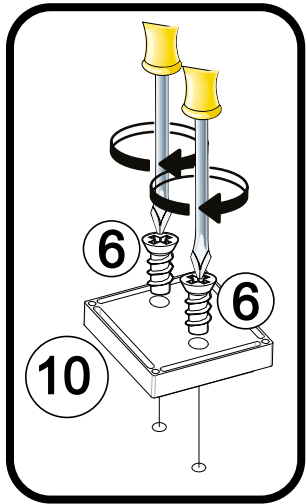
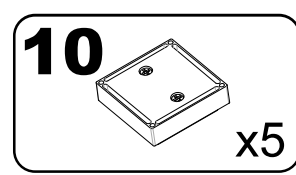
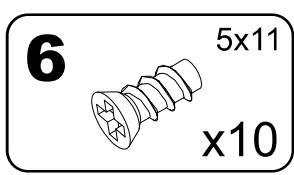

16

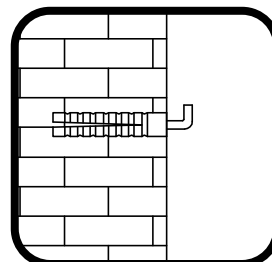
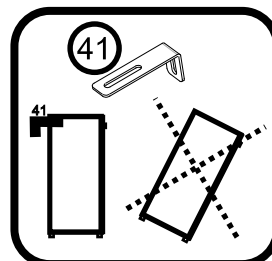
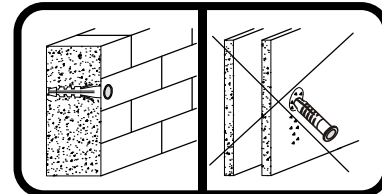
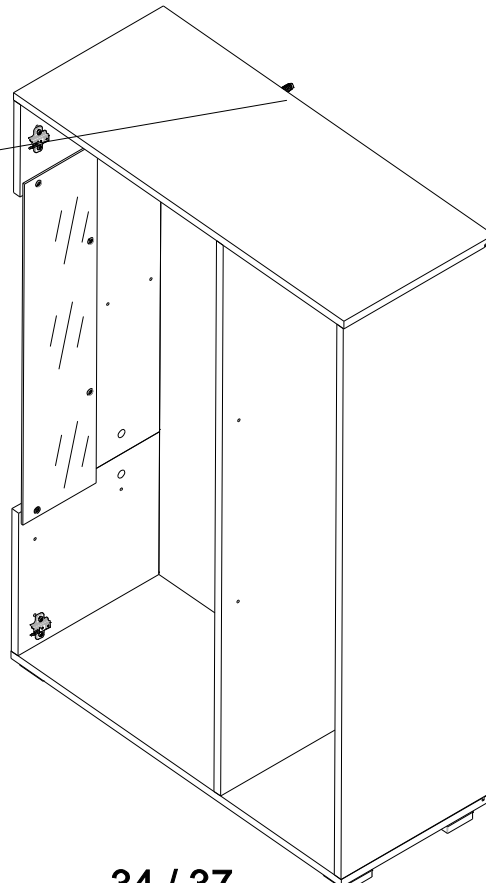
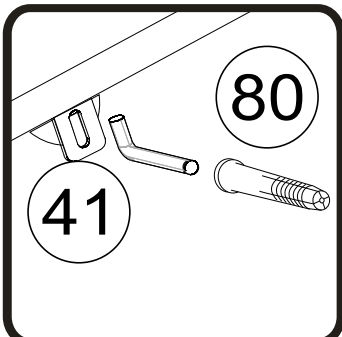
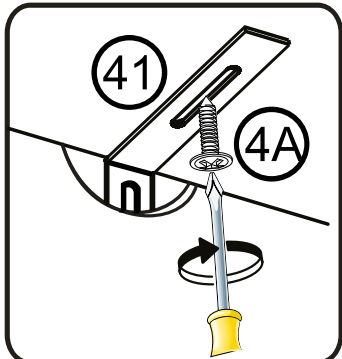
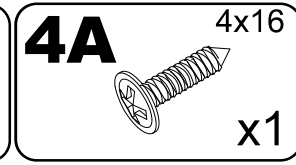
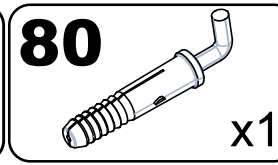
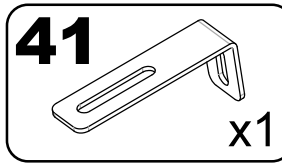

17

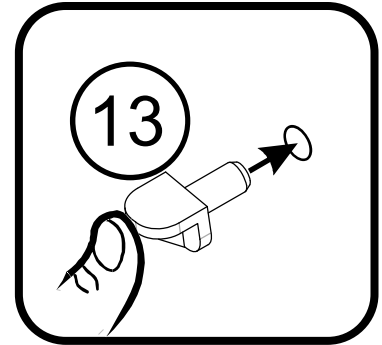
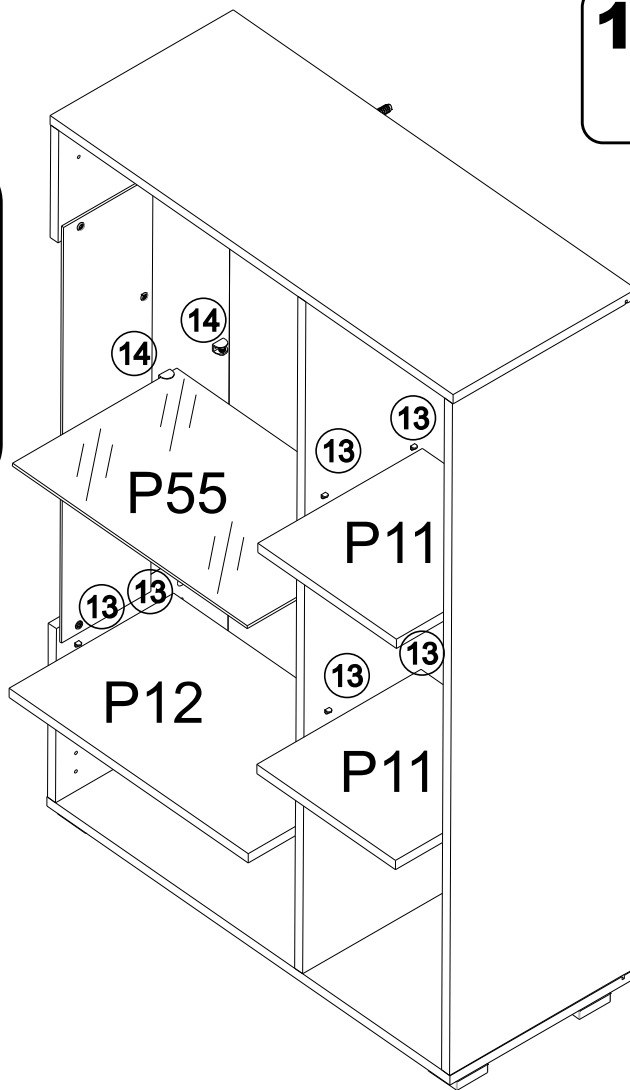
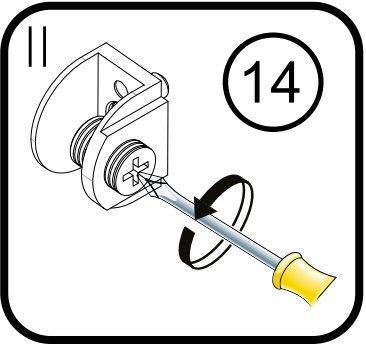
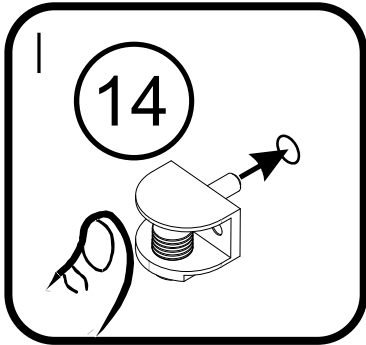
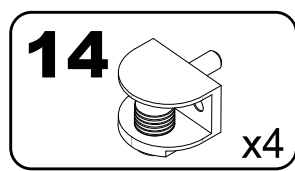
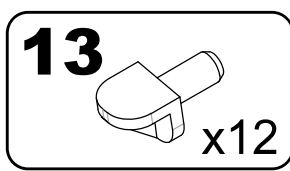

18

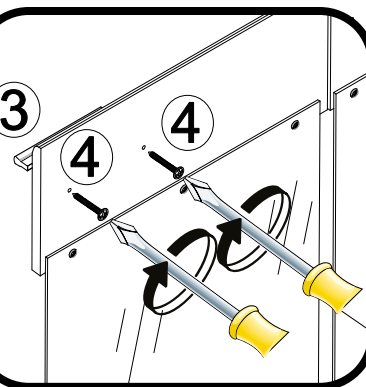
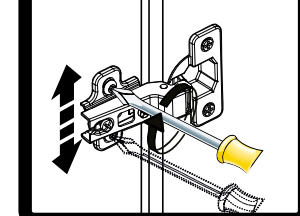
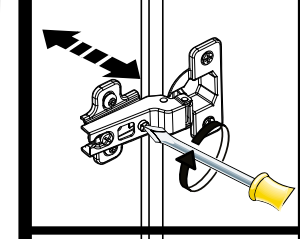
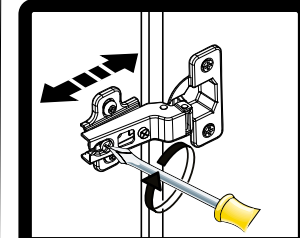
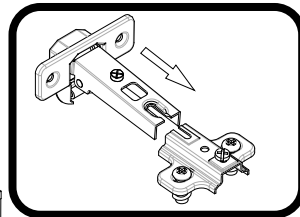
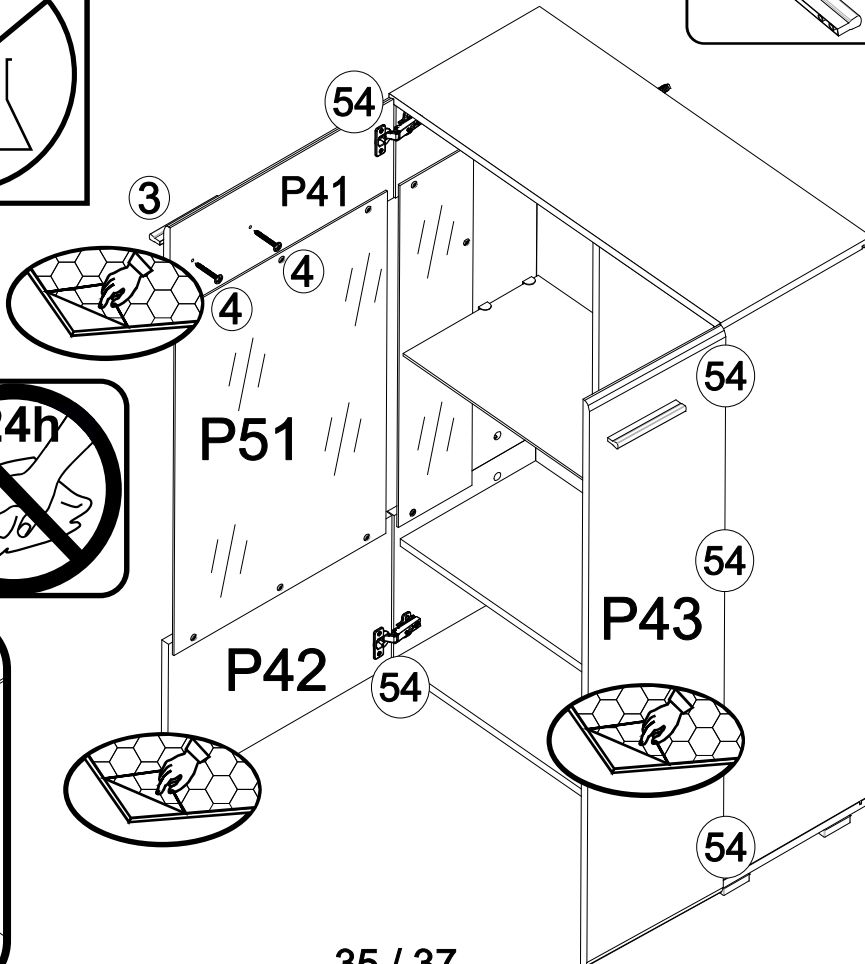
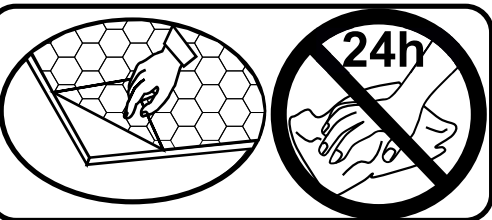
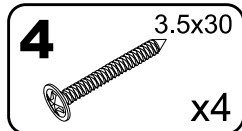
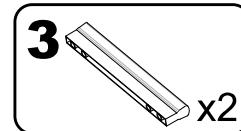

I

- 6** 5x11 x6
- 22** x10
- 22A** x10
- 26** x1
- 72** x3
- 93** 4x12 x2

	A	B (mm)	C (mm)	D (mm)	E	F
N01		1500	195	16	1	2/5
N02		1494	195	16	1	2/5

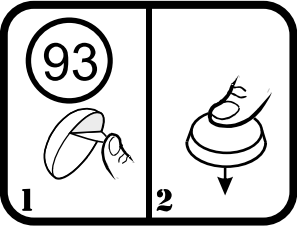
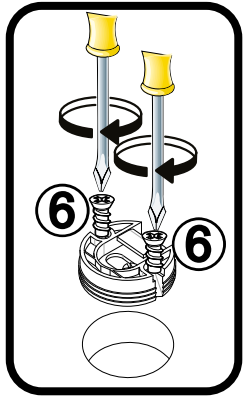
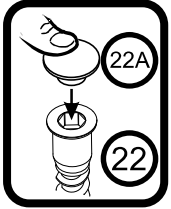
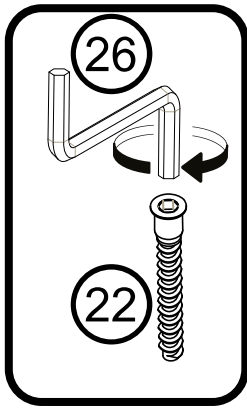
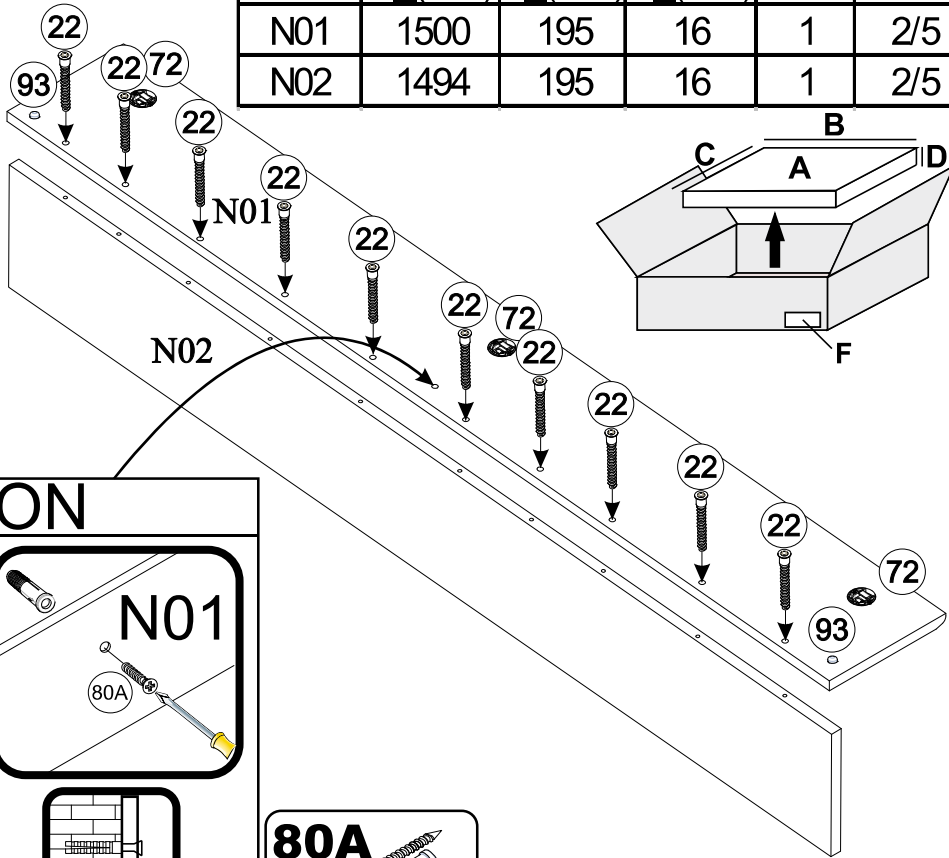

OPTION

N01

N01

80A x1

- 2** **80** x3

