

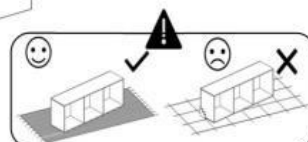

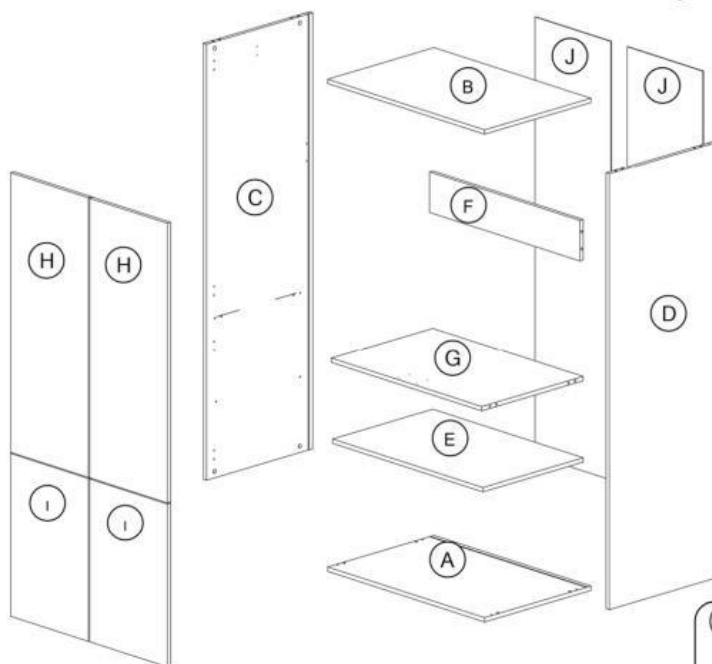

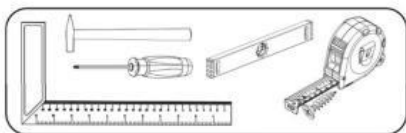

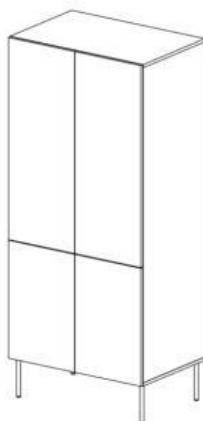



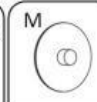
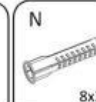

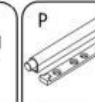
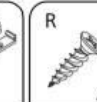

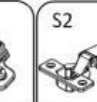
ASENSIO SZAFA

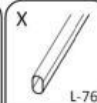

 x16	 x16	 x16	 8x30 x12	 x4	 x4	 4x16 x20	 x8	 x8	 x4
 6,3x13 x16	 x2	 L-766 x1	 L-1615 x1	 x10	 x1				



1

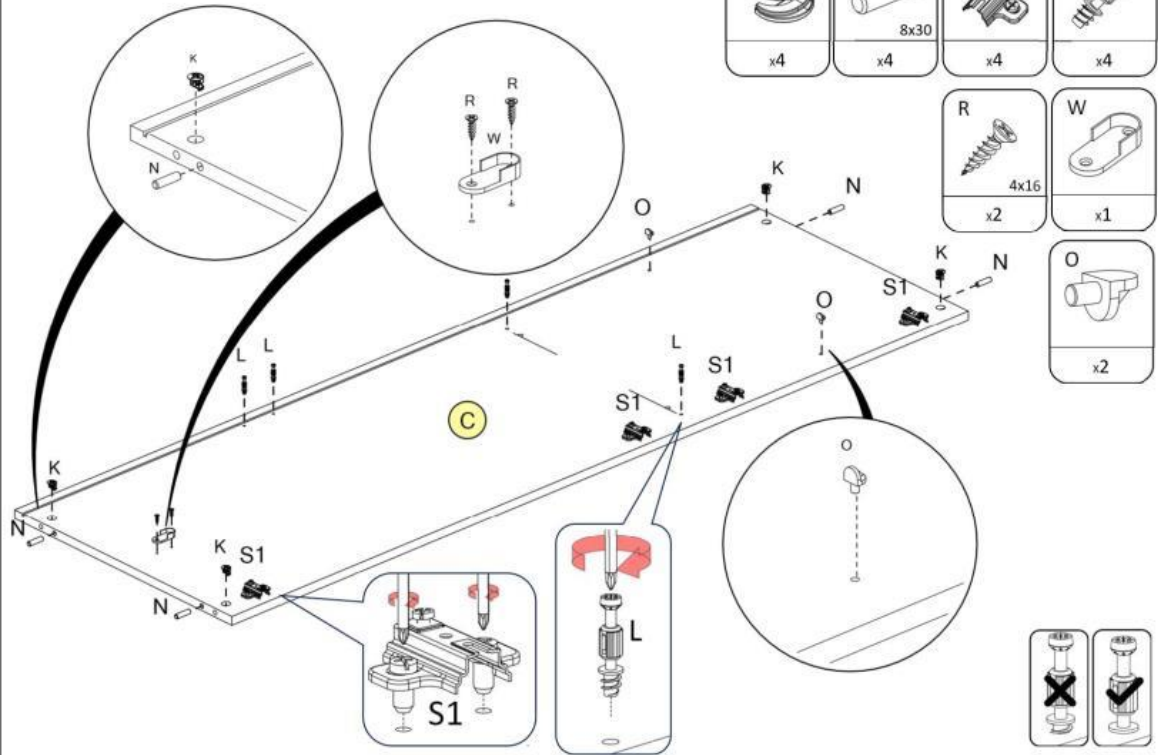

2

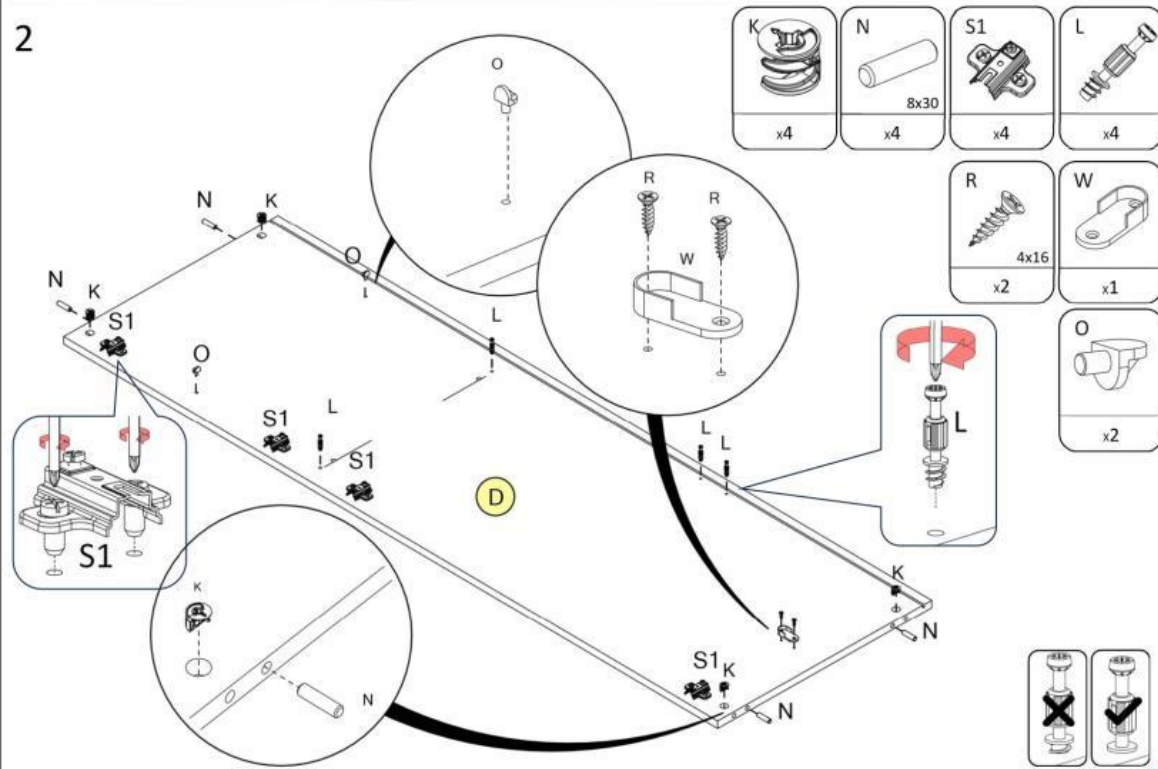

3

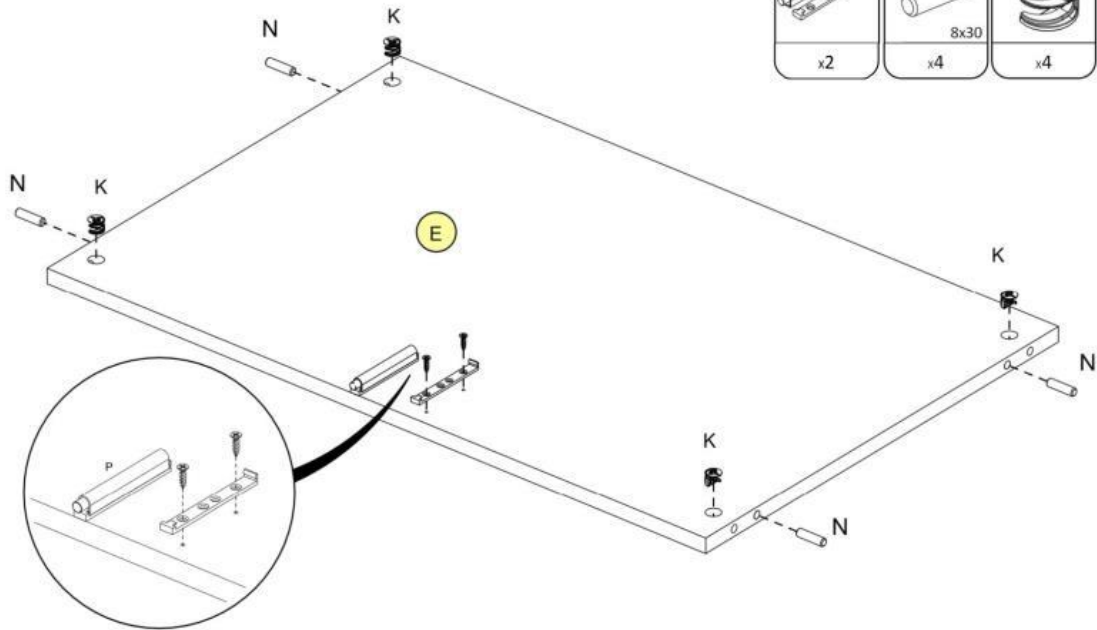

4

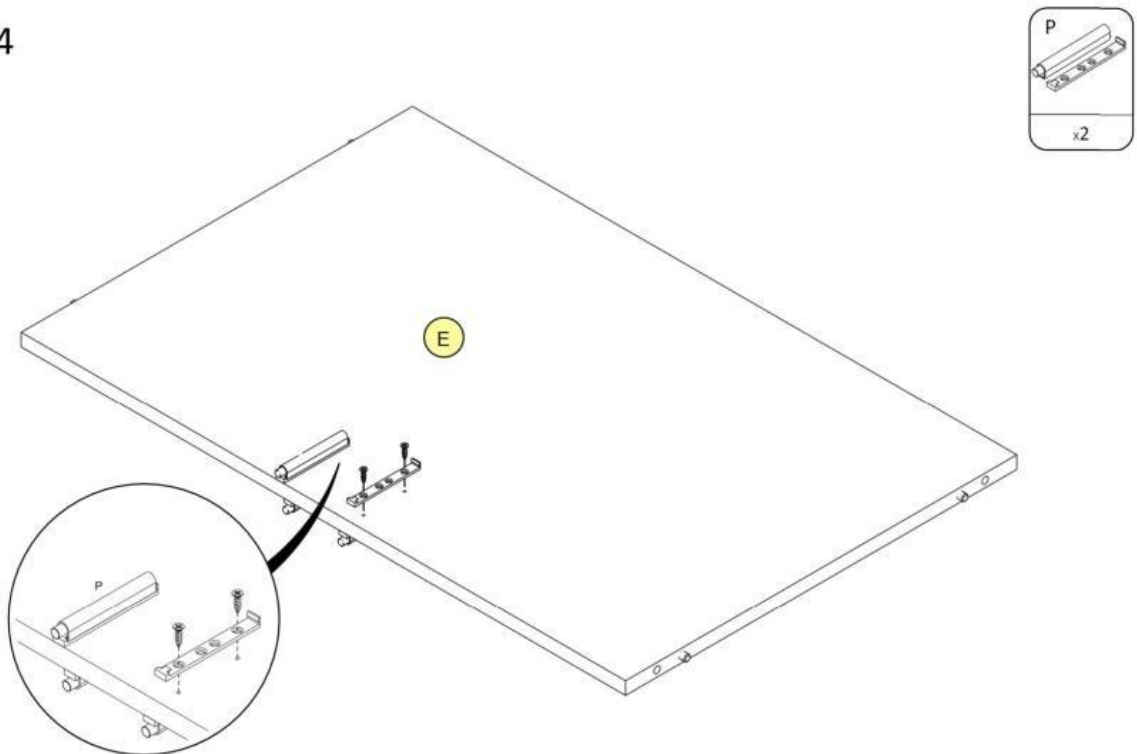

5

6

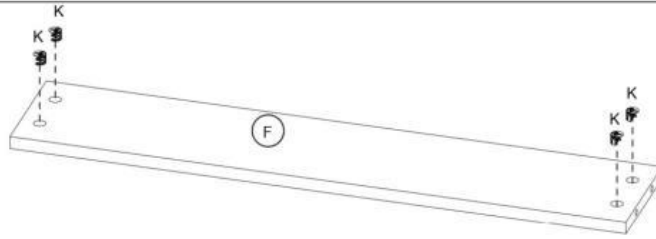

6

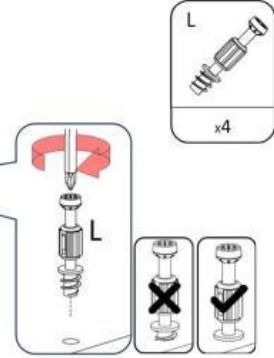
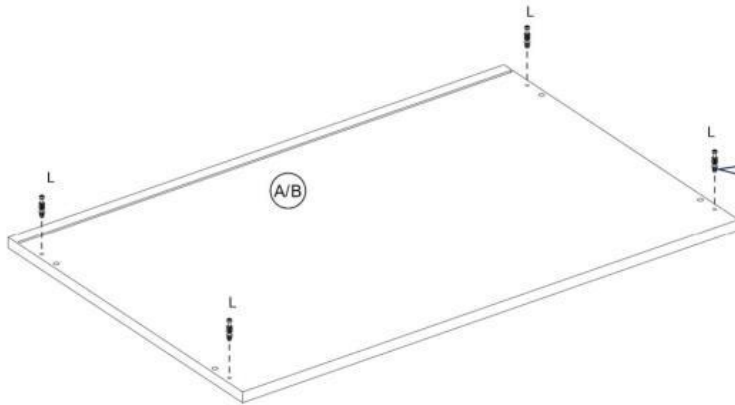

7

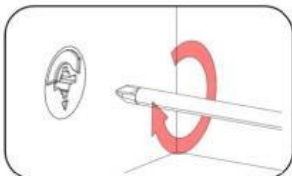
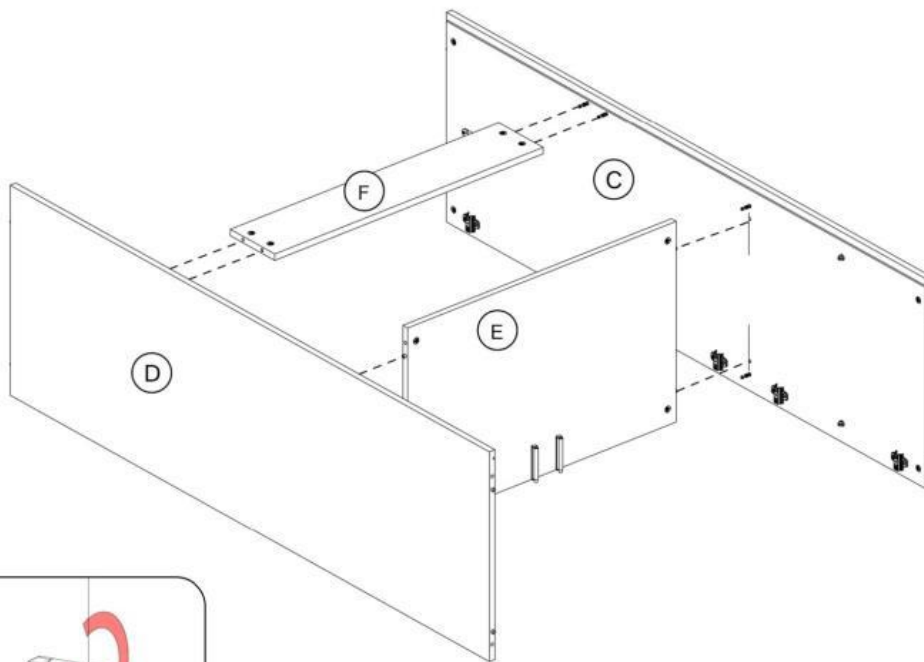

8

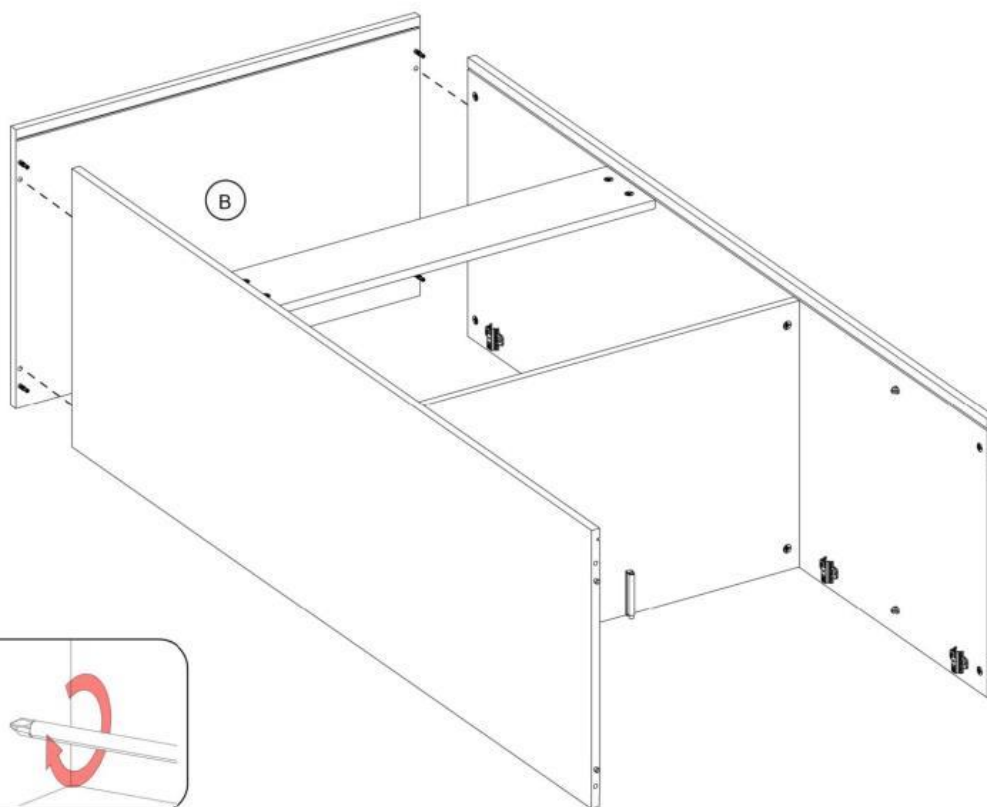

9

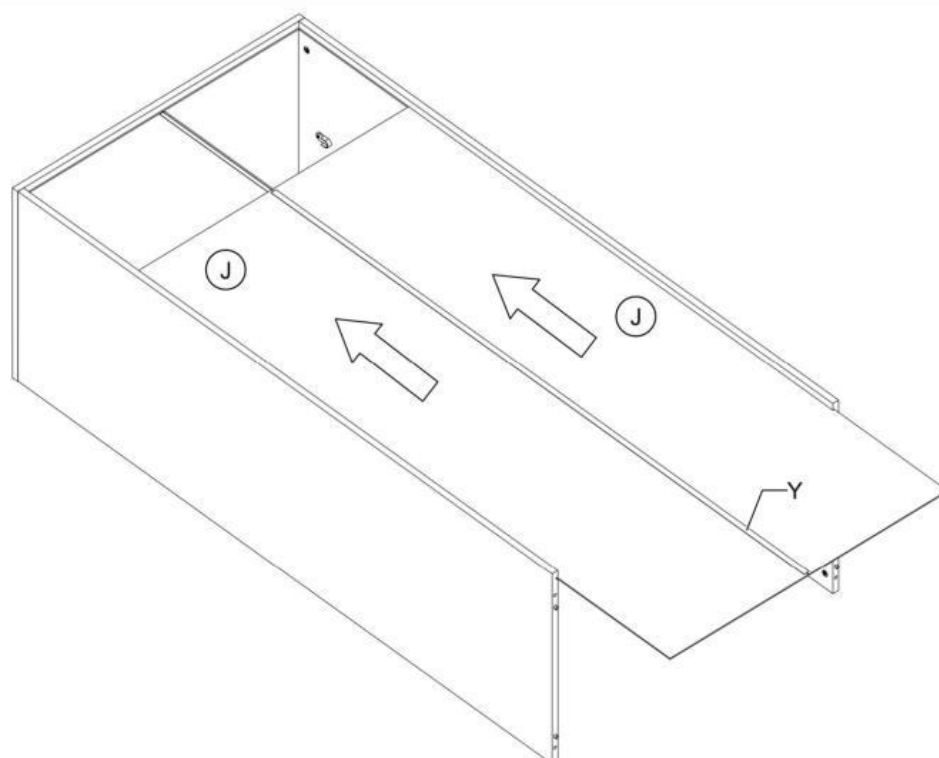

10

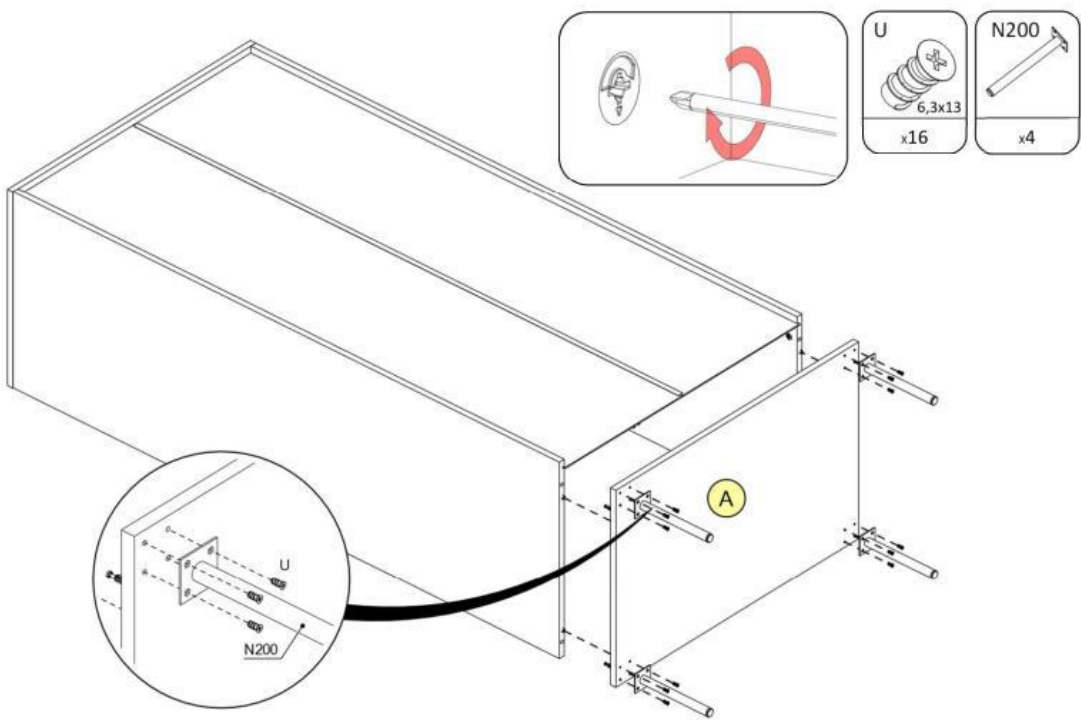

11

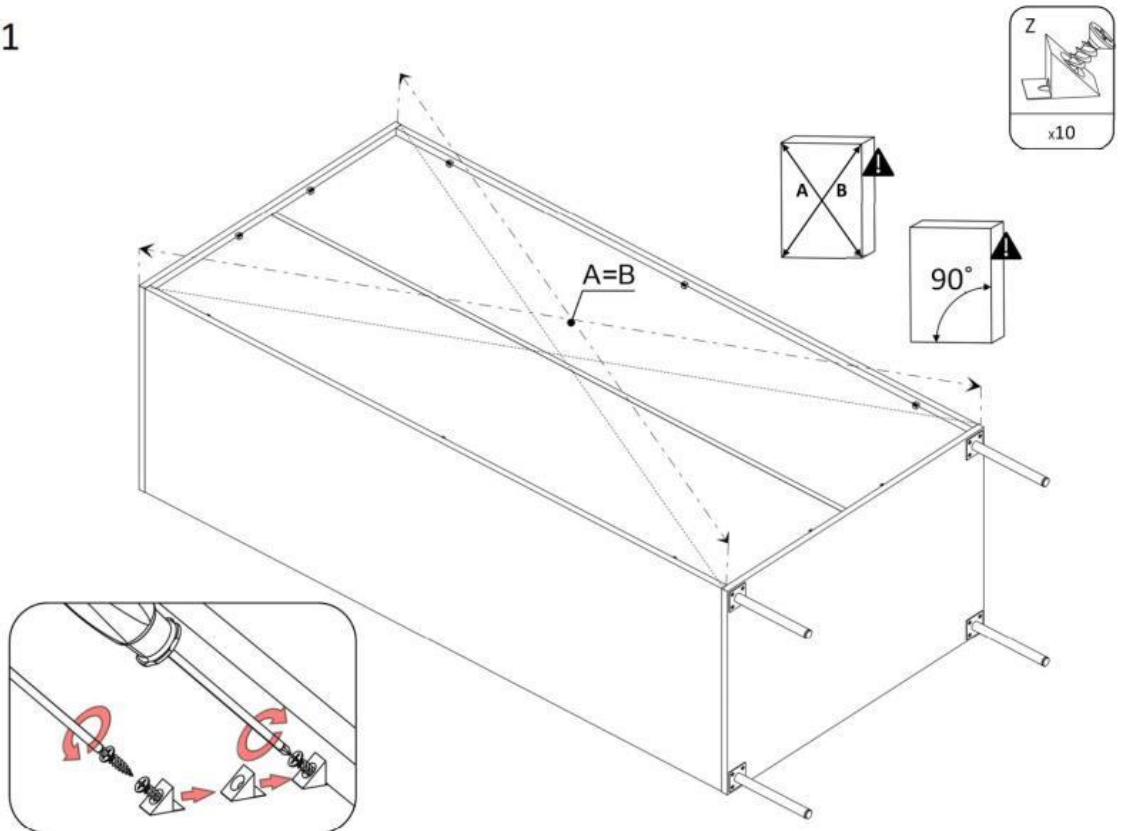

12

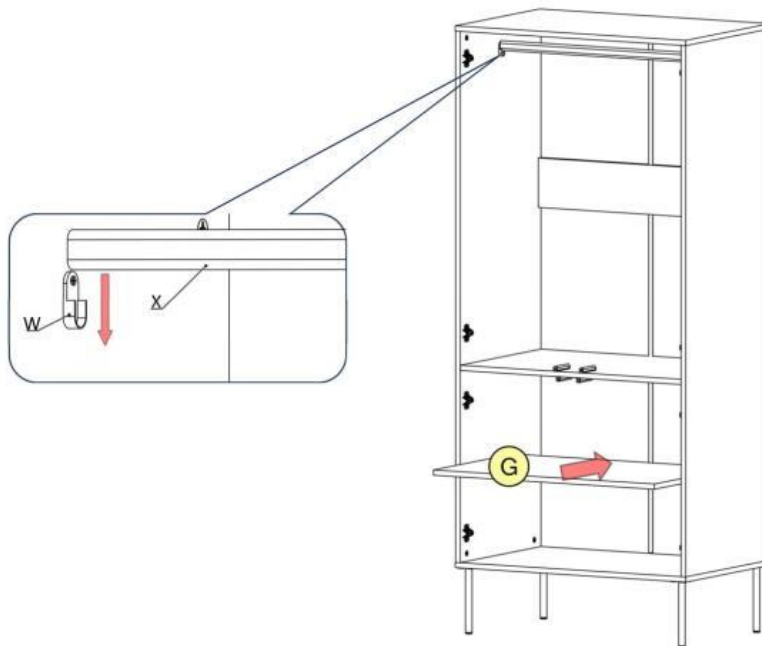
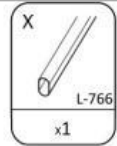

13

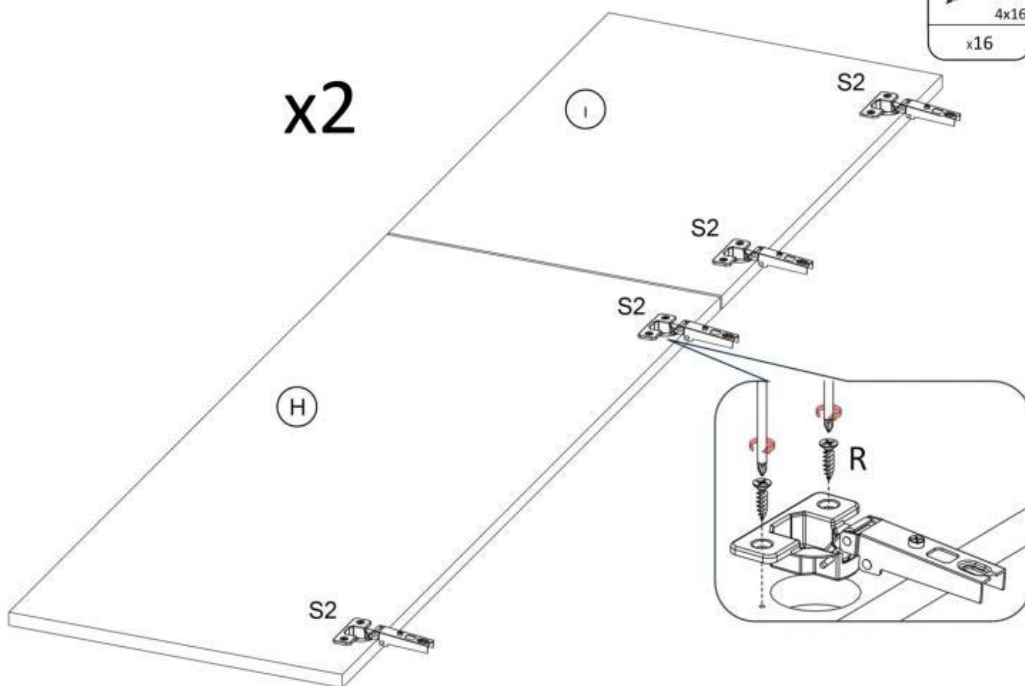
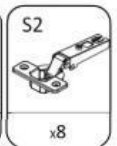
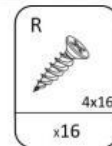

14

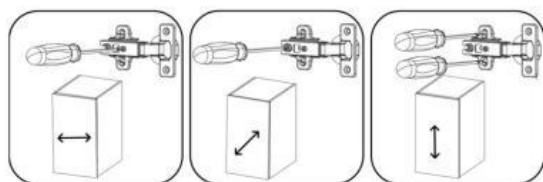
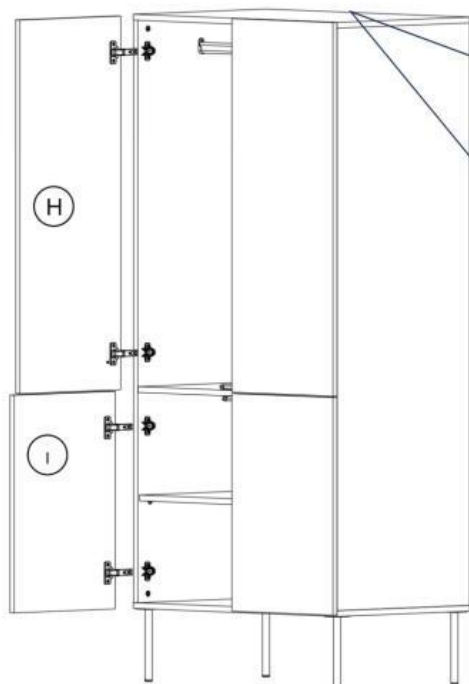
**PL - UWAGA!**

W przypadku reklamacji prosimy o podanie numeru serii znajdującego się na kartonie. W związku z tym prosimy o zachowanie opakowań do momentu zmontowania mebla. W przypadku stwierdzenia uszkodzenia któregoś z elementów, prosimy nie montować modułu, którego częścią jest dany element.

DE - HINWEIS!

Im Falle einer Reklamation geben Sie bitte die Seriennummer, die sich auf der Verpackung befindet. Daher bitten wir Sie immer die Verpackung solange aufzubewahren, bis die Möbelstücke vollständig montiert sind. Sollten Schäden an Einzelteilen auftreten, bitte sehen Sie von der Montage des Moduls ab.

EN - ATTENTION!

In case of claim please give us series number which you can find on the box. Thereupon please keep the package until montage of furniture is done. In case verified damage any of elements, please do not mount module, which is a parts of particular element.

CZ - POZOR!

Při reklamaci prosíme o uvedení čísla šarže, které se nachází na obale. V souvislosti s tímto prosíme o uchování obalů do okamžiku složení nábytku. V případě poškození některého z dílů, prosíme neskládat model, jehož součástí poškozený díl je.

HR - PAŽNJA!

U slučaju reklamacije, molimo Vas da nam date serijski broj koji možete pronaći na ambalaži. Molimo Vas da zadržite ambalažu sve dok nije kompletna montaža proizvoda. Ukoliko je uočeno oštećenje bilo kojeg elementa, molim Vas da ne montirate oštećeni dio.

HU - FIGYELEM!

A bútór összeszereléséig kérjük őrizze meg a csomagolást, mivel reklamáció esetén a kartonon található sziériaszámot kell megadni. Amennyiben észreveszi, hogy valamelyik bútorelem sérült kérjük ne folytassa az összeszerelését a modulnak melynek része az adott elem.

SK - POZOR!

V prípade sťažností uveďte číslo šarže na balení. Balenie preto uschovajte, kým nezostavíte nábytok. V prípade poškodenia niektorého z komponentov, nemontujte modul, ktorého je prvok súčasťou.