

ESTELLA 160

A	HEADBOARD	1
B	HEADBOARD WING (L & R)	2
C	FOOTBOARD	1
D	SIDERAIL	2
E	CENTER SUPPORT	1
F	CENTER SUPPORT LEG	3
G	SLATS	1
H	BED LEG	4

I	JCBC BOLT M6 x 60mm		3
J	JCBB BOLT M8 x 40mm		8
K	FLAT WASHER M8 x 18mm		8
L	SPRING WASHER M8 x 13mm		8
M	CSK SCREW M4 x 38mm		9
N	CSK SCREW M4 x 20mm		2
O	JCBB BOLT M8 x 25mm		8
P	ALLEN KEY M4&M5		1

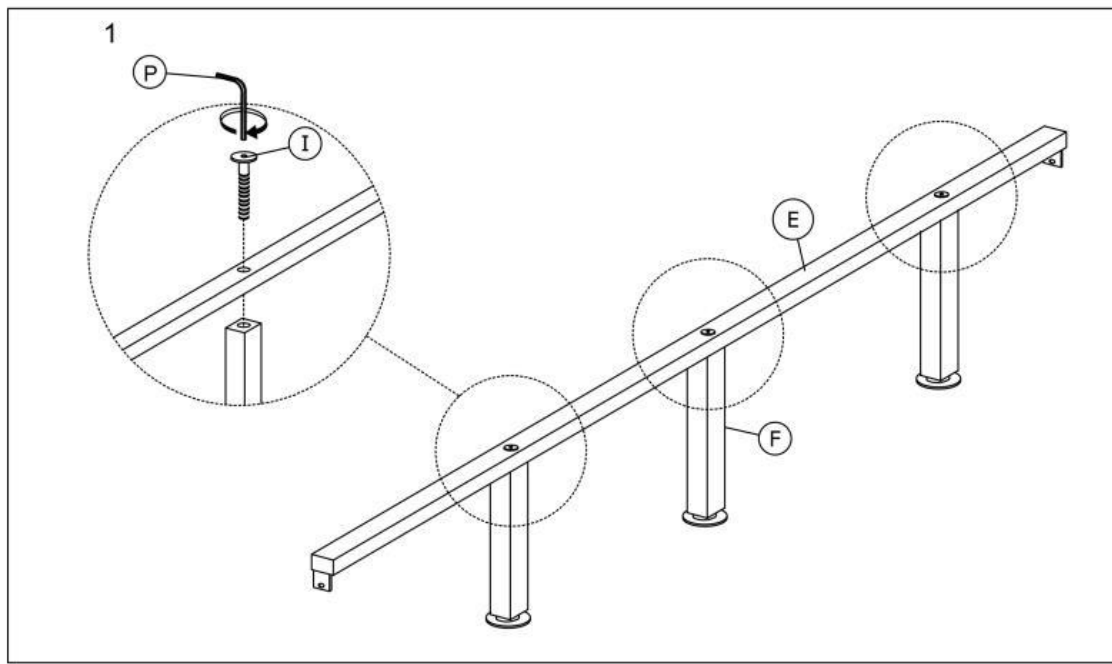
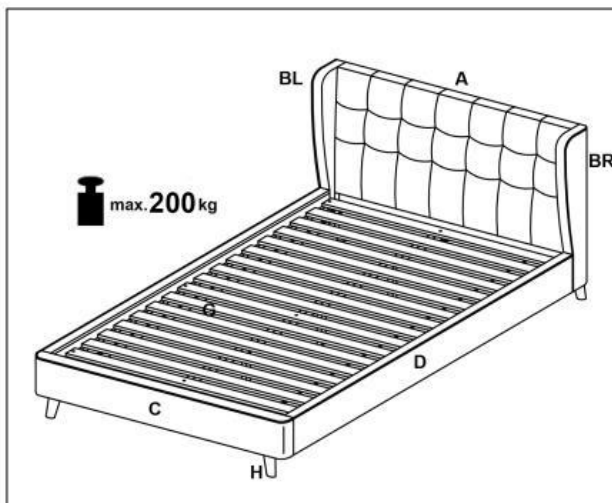

HALMAR Sp. z o.o.

ul. Centralnego Okręgu Przemysłowego 2, 37-450 Stalowa Wola, POLSKA / POLAND
tel. +48 15 843 28 10, fax: +48 15 842 19 57, e-mail: office@halmar.com.pl

v.1

1
NOWOŚĆ

ESTELLA 160

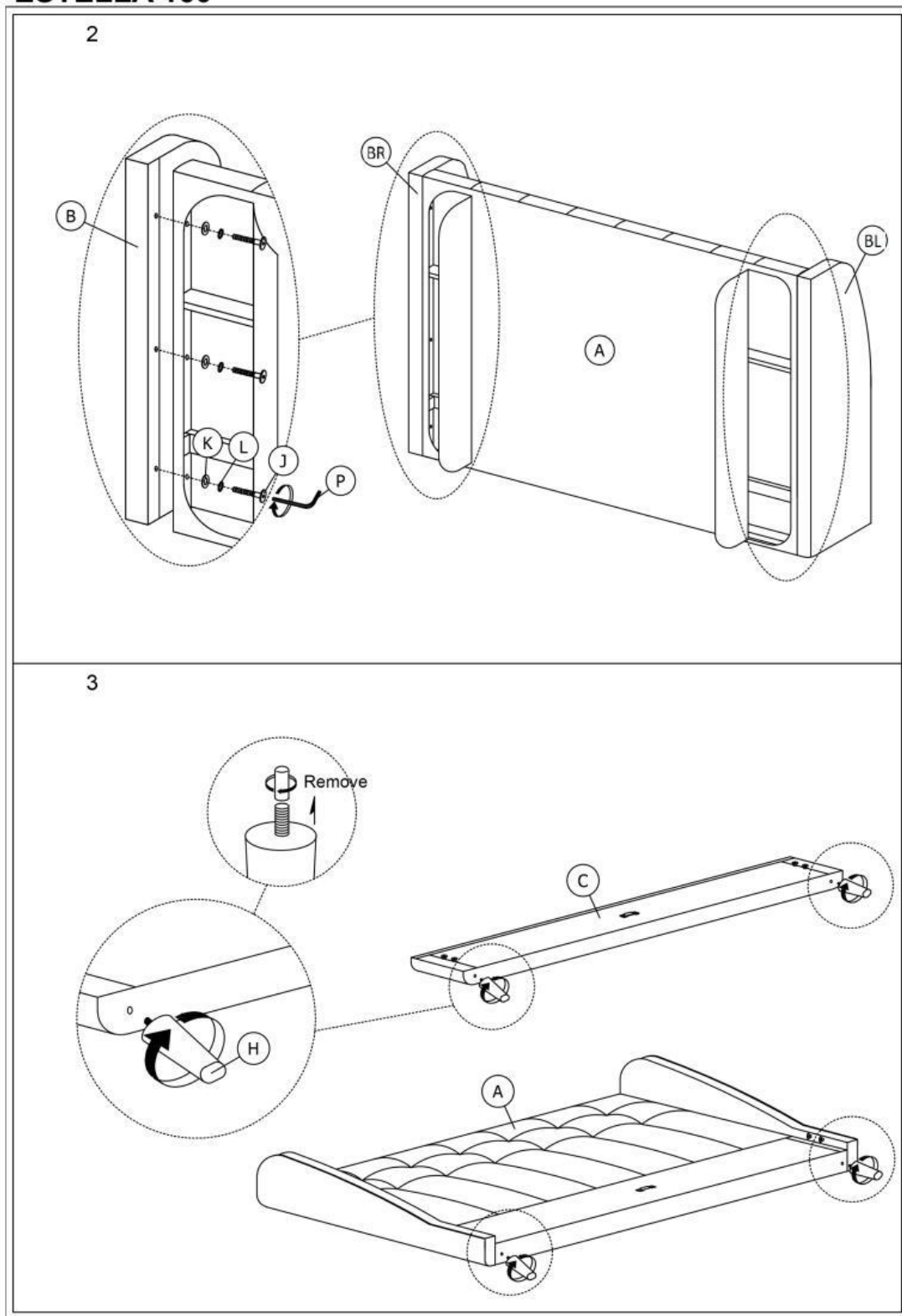

ESTELLA 160

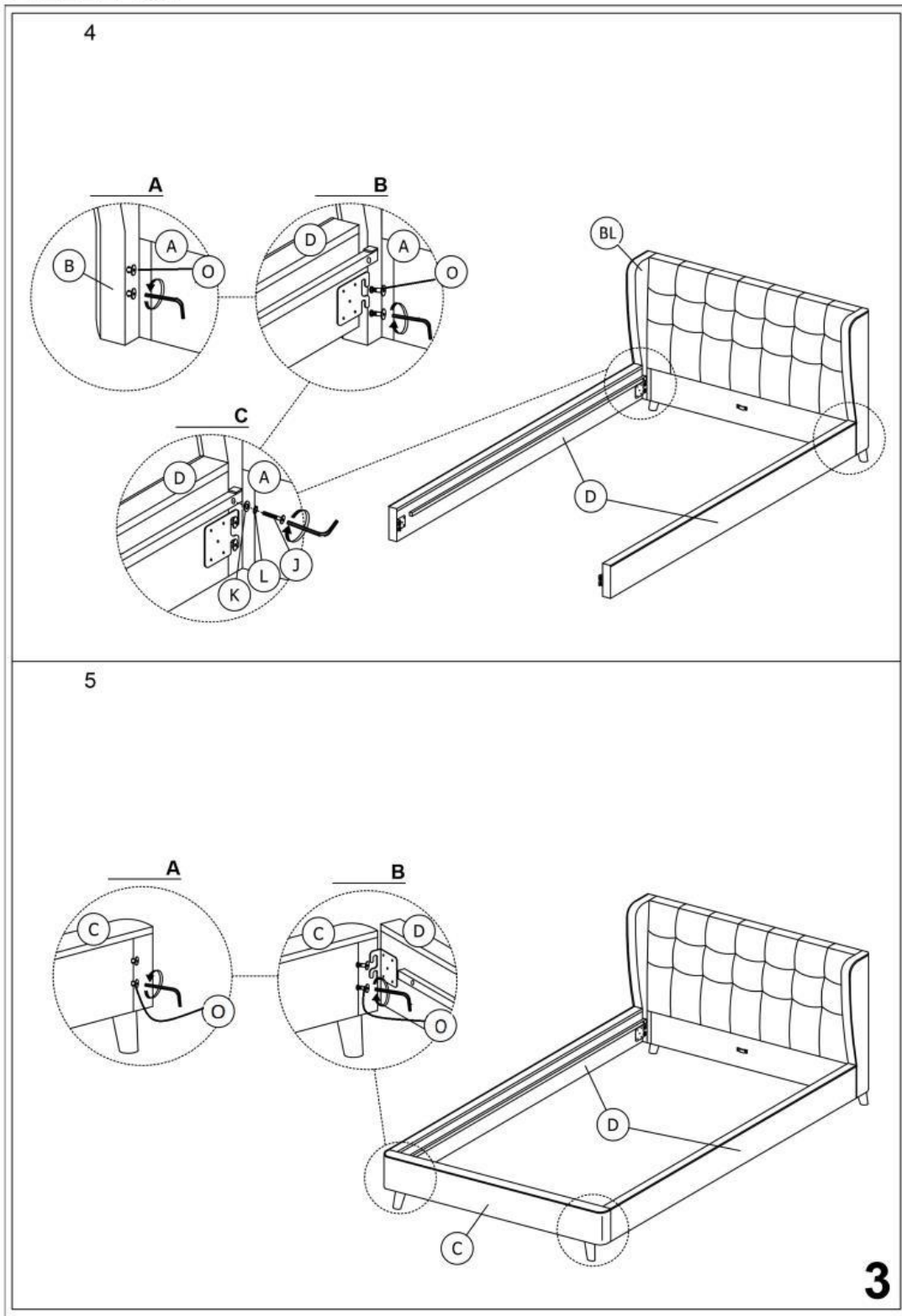

NOWOŚĆ

ESTELLA 160

6

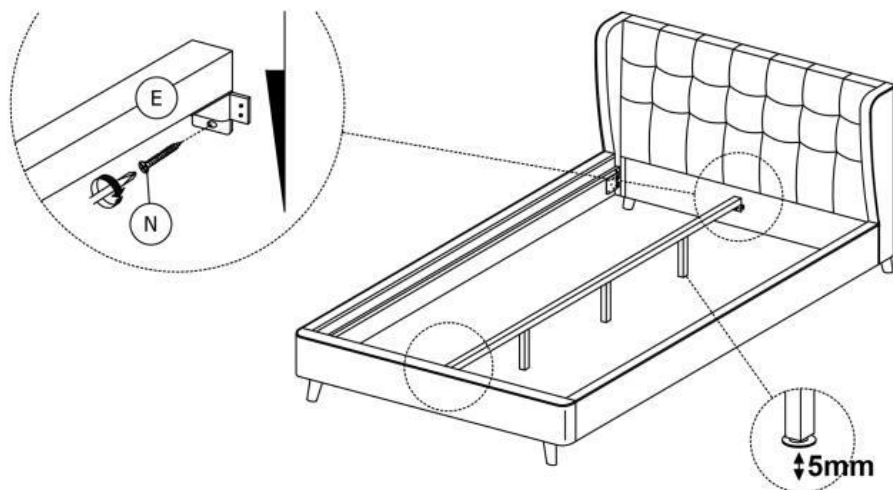

7

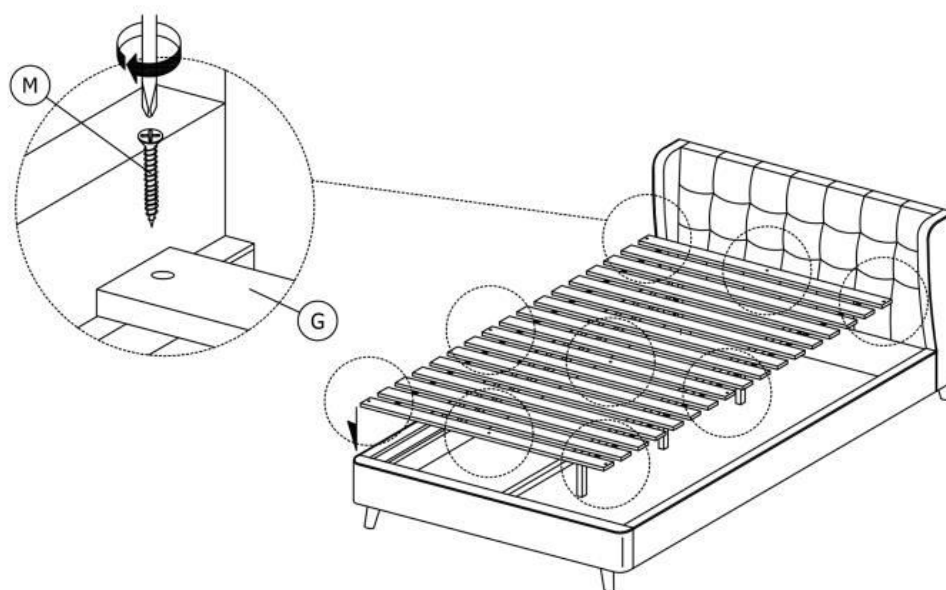

4

NOWOŚĆ