

# Model P-008

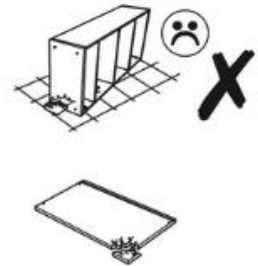

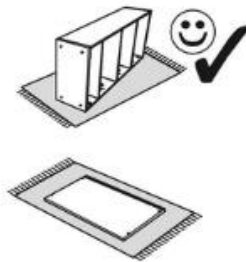

A	B	C	(mm)	
1	001	678	153	1\1
2	002	678	399	1\1
3	003	678	399	1\1
4	004	566	384	1\1
5	005	566	384	1\1
6	006	406	384	1\1
7	007	406	384	1\1
8	008	683	404	1\1
9	009	683	404	1\1
10	010	834	600	1\1
11	011	600	116	1\1
12	012	955	410	1\1
13	013	900	116	1\1
14	014	640	70	1\1
15	015	640	70	1\1
16	016	350	100	1\1
17	017	593	100	1\1
18	018	350	100	1\1
19	019	620	353	1\1
20	020	434	678	1\1
21	021	593	678	1\1

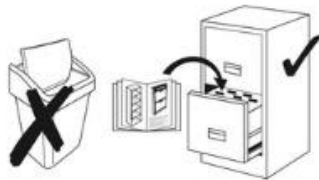
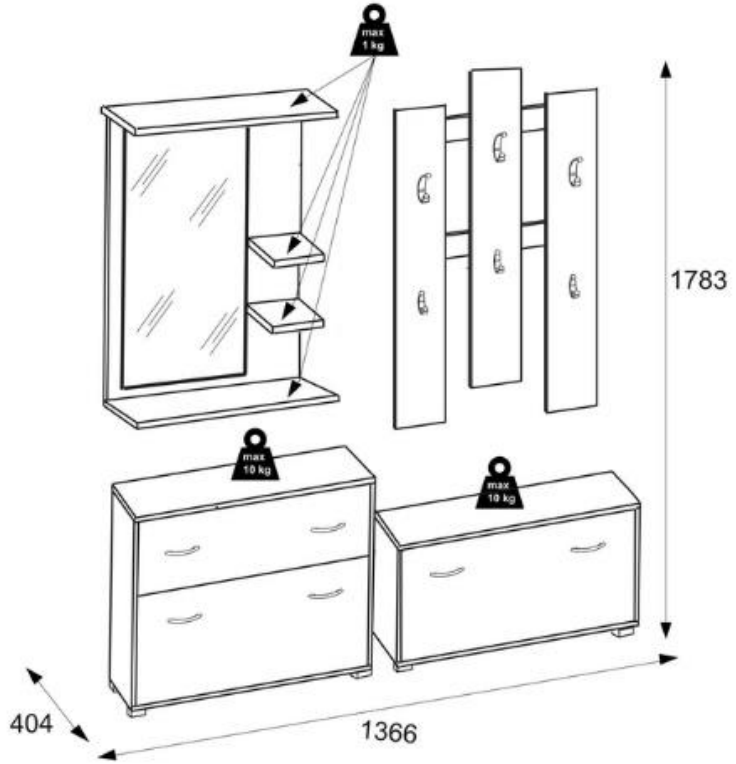
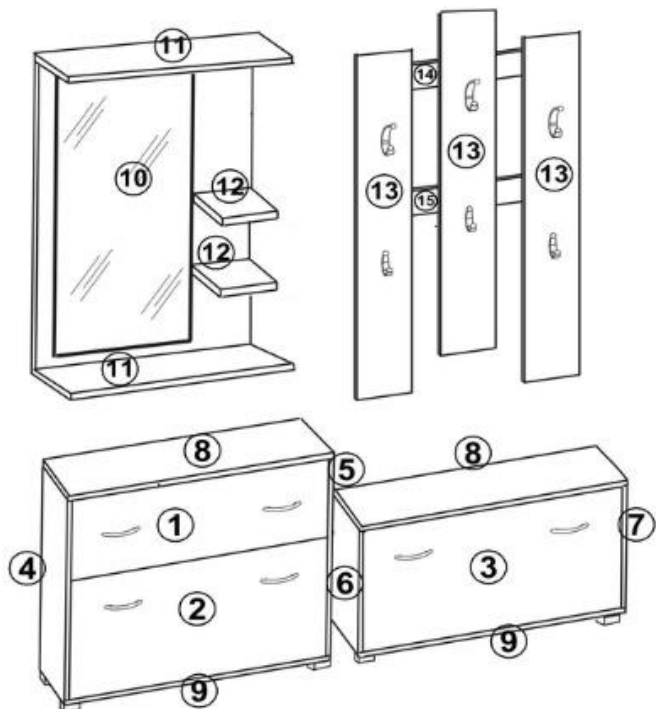







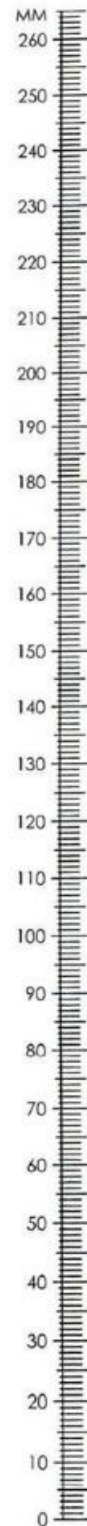
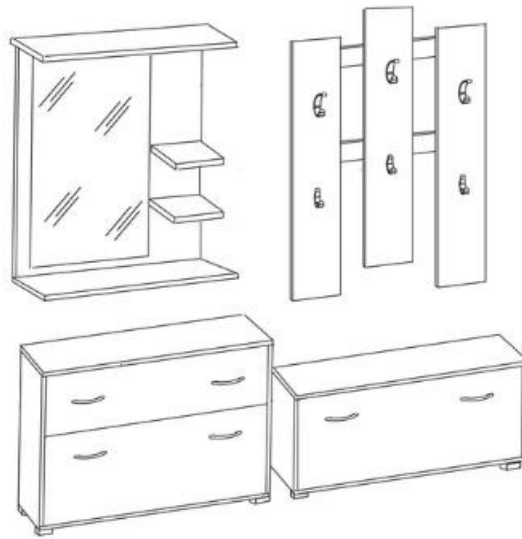











**PL-** Proszę nie montować mebla, jeśli jego elementy są uszkodzone. Przed zmontowaniem poszczególne elementy mebla należy dokładnie obejrzeć. W przypadku uszkodzeń, należy je zgłosić wraz z dokumentacją zdjęciową, celem rozpatrzenia reklamacji i podjęcia właściwych działań.

**EN-** Please do not assemble the furniture if its parts are damaged. Before assembling, individual elements of the furniture should be carefully inspected. In case of visible damage, it should be reported along with photographic documentation, to analyse the complaint and take appropriate action.

**FR-** Si vous constatez que les pièces sont endommagées, veuillez ne pas monter le meuble. Avant le montage, les éléments individuels du mobilier doivent être soigneusement inspectés. En cas d'un endommagement, ils doivent être signalés avec la documentation photographique afin d'examiner la réclamation et de prendre les mesures appropriées.

**DE-** Bitte montieren Sie die Möbel nicht, wenn ihre Teile beschädigt sind. Vor dem Zusammenbau sollten einzelne Elemente der Möbel sorgfältig geprüft werden. Im Schadensfall sollten sie zusammen mit der Foto Dokumentation gemeldet werden, um die Beschwerde zu prüfen und geeignete Maßnahmen zu ergreifen.



	1x  GL	8x  e5 φ5x11 mm
32x  φ3,5x16 mm	1x  4mm L	4x  φ35x12 mm g2
8x  φ 18	6x  115x60 y1	60x  φ2x20 mm g1
18x  φ 12	32x  φ8x30 mm f1	8x  φ 5 x
8x  44mm r23	8x  φ1,5x12mm r1	18x  φ6,4x50 mm e27
1x  L=350 mm K	4x  φ40x50x12 mm b19	4x  φ 35 b20
4x  R	6x  L=128 mm c235	8x  U
12x  φ 3,5x30 mm p21	12x  φ4x22 mm p22	12x  φ4x27 mm p23

