

# Elite

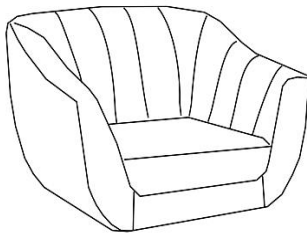

1x

+

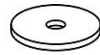

4x

+



4x

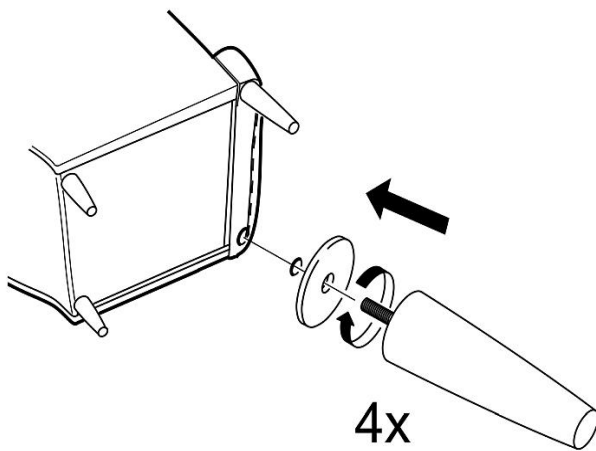

4x

